

Rosemount™ 3051 Pressure Transmitter

with HART® Protocol



Contents

Section 1: Introduction

1.1	Using this manual	1
1.2	Models covered	1
1.3	Product recycling/ disposal	2

Section 2: Configuration

2.1	Overview	3
2.2	Safety messages	3
2.3	Commissioning	4
2.3.1	Setting the loop to manual	4
2.3.2	Wiring diagrams	4
2.4	Configuration data review	6
2.5	Field Communicator	7
2.5.1	Field Communicator user interface	7
2.6	Field Communicator menu trees	8
2.7	Traditional Fast Key sequence	12
2.8	Check output	14
2.8.1	Process variables	15
2.8.2	Sensor temperature	15
2.9	Basic setup	15
2.9.1	Set process variable units	15
2.9.2	Set output (transfer function)	16
2.9.3	Rerange	17
2.9.4	Damping	20
2.10	LCD display	21
2.10.1	LCD display configuration for 4–20 mA HART only	21
2.10.2	Custom display configuration 4–20 mA HART only	22
2.11	Detailed setup	23
2.11.1	Failure mode alarm and saturation	23
2.11.2	Alarm and saturation levels for burst mode	24
2.11.3	Alarm and saturation values for multidrop mode	24
2.11.4	Alarm level verification	24
2.12	Diagnostics and service	24
2.12.1	Loop test	24
2.13	Advanced functions	26
2.13.1	Saving, recalling, and cloning configuration data	26

2.13.2 Burst mode	28
2.14 Multidrop communication	29
2.15 Changing a transmitter address	30
2.15.1 Communicating with a multidropped transmitter	30
2.15.2 Polling a multidropped transmitter	30

Section 3: Installation

3.1 Overview	31
3.2 Safety messages	31
3.3 General considerations	32
3.4 Mechanical considerations	32
3.5 Draft range considerations	33
3.6 Environmental considerations	33
3.7 HART installation flowchart	34
3.8 Installation procedures	35
3.8.1 Mount the transmitter	35
3.8.2 Impulse piping	39
3.8.3 Process connections	41
3.8.4 Inline process connection	42
3.8.5 Housing rotation	43
3.8.6 LCD display	44
3.8.7 Configure security and alarm	44
3.9 Electrical considerations	46
3.9.1 Conduit installation	46
3.9.2 Wiring	46
3.9.3 Transient protection terminal block	48
3.9.4 Grounding	50
3.10 Hazardous locations certifications	51
3.11 Rosemount 305, 306, and 304 Manifolds	51
3.11.1 Rosemount 305 Integral Manifold installation procedure	52
3.11.2 Rosemount 306 Integral Manifold installation procedure	53
3.11.3 Rosemount 304 Conventional Manifold installation procedure	53
3.11.4 Manifold operation	53
3.12 Liquid level measurement	59
3.12.1 Open vessels	59
3.12.2 Closed vessels	59

Section 4: Operation and Maintenance

4.1	Overview	63
4.2	Safety messages	63
4.3	Calibration overview	64
4.3.1	Determining calibration frequency	66
4.3.2	Selecting a trim procedure	68
4.4	Analog output trim	68
4.4.1	Digital-to-Analog trim	69
4.4.2	Digital-to-Analog trim using other scale	70
4.4.3	Recall factory trim—analog output	71
4.5	Sensor trim	71
4.5.1	Sensor trim overview	71
4.5.2	Zero trim	72
4.5.3	Sensor trim	73
4.5.4	Recall factory trim—sensor trim	74
4.5.5	Line pressure effect (range 2 and 3)	74
4.5.6	Compensating for line pressure	75

Section 5: Troubleshooting

5.1	Overview	77
5.2	Safety messages	77
5.3	Diagnostic messages	79
5.4	Disassembly procedures	84
5.4.1	Remove from service	84
5.4.2	Remove terminal block	84
5.4.3	Remove the electronics board	85
5.4.4	Remove the sensor module from the electronics housing	85
5.5	Reassembly procedures	85
5.5.1	Attach the electronics board	86
5.5.2	Install the terminal block	86
5.5.3	Reassemble the Rosemount 3051C process flange	86

Appendix A: Specifications and Reference Data

A.1	Performance specifications	89
A.1.1	Conformance to specification ($\pm 3\sigma$ [Sigma])	89
A.1.2	Reference accuracy	89
A.1.3	Total performance	90
A.1.4	Long term stability	90

A.1.5	Dynamic performance	91
A.1.6	Line pressure effect per 1000 psi (6,9 MPa)	91
A.1.7	Ambient temperature effect per 50 °F (28 °C)	91
A.1.8	Mounting position effects	92
A.1.9	Vibration effect	92
A.1.10	Power supply effect	92
A.1.11	Electromagnetic compatibility (EMC)	92
A.1.12	Transient protection (option code T1)	92
A.2	Functional specifications	93
A.2.1	Range and sensor limits	93
A.2.2	Zero and span adjustment requirements (HART and Low Power)	94
A.2.3	Service	94
A.2.4	4–20 mA (output code A)	94
A.2.5	Foundation Fieldbus (output code F) and PROFIBUS® (output code W)	94
A.2.6	Foundation Fieldbus function block execution times	95
A.2.7	Foundation Fieldbus parameters	95
A.2.8	Standard function blocks	95
A.2.9	Backup Link Active Scheduler (LAS)	95
A.2.10	Advanced control function block suite (option code A01)	95
A.2.11	Foundation Fieldbus Diagnostics Suite (option code D01)	96
A.2.12	Low Power (output code M)	96
A.2.13	Static pressure limit	96
A.2.14	Burst pressure limits	97
A.2.15	Failure mode alarm	97
A.2.16	Temperature limits	98
A.3	Physical specifications	99
A.3.1	Electrical connections	99
A.3.2	Process connections	99
A.3.3	Process-wetted parts	99
A.3.4	Rosemount 3051L process wetted parts	99
A.3.5	Non-wetted parts	100
A.3.6	Shipping weights	100
A.4	Dimensional drawings	101
A.5	Ordering information	113
A.6	Options	130
A.7	Spare parts	136

Appendix B: Product Certifications

B.1	European directive information	145
B.2	Ordinary location certification	145
B.3	North America	145
B.4	Europe	146
B.5	International	148
B.6	Brazil	149
B.7	China	150
B.8	Japan	151
B.9	Technical Regulations Customs Union (EAC)	151
B.10	Combinations	151
B.11	Conduit plugs and adapters	152
B.12	Additional Certifications	152
B.13	Approval drawing	153
B.13.1	Factory mutual 03031-1019	153
B.13.2	Canadian standards association (CSA) 03031-1024	166

Rosemount™ 3051 Pressure Transmitter

NOTICE

Read this manual before working with the product. For personal and system safety, and for optimum product performance, make sure you thoroughly understand the contents before installing, using, or maintaining this product.

For technical assistance, contacts are listed below:

Customer Central

Technical support, quoting, and order-related questions.

United States - 1-800-999-9307 (7:00 am to 7:00 pm CST)

Asia Pacific- 65 777 8211

Europe/ Middle East/ Africa - 49 (8153) 9390

North American Response Center

Equipment service needs.

1-800-654-7768 (24 hours—includes Canada)

Outside of these areas, contact your local Emerson™ representative.

⚠ CAUTION

The products described in this document are NOT designed for nuclear-qualified applications. Using non-nuclear qualified products in applications that require nuclear-qualified hardware or products may cause inaccurate readings.

For information on Rosemount nuclear-qualified products, contact your local Emerson Sales Representative.

⚠ WARNING

Explosions could result in death or serious injury.

Installation of this transmitter in an explosive environment must be in accordance with the appropriate local, national, and international standards, codes, and practices. Review the approvals section of this manual for any restrictions associated with a safe installation.

- Before connecting a Field Communicator in an explosive atmosphere, ensure the instruments in the loop are installed in accordance with intrinsically safe or non-incendive field wiring practices.
- In an explosion-proof/flameproof installation, do not remove the transmitter covers when power is applied to the unit.

Process leaks may cause harm or result in death.

- Install and tighten process connectors before applying pressure.

Electrical shock can result in death or serious injury.

- Avoid contact with the leads and terminals. High voltage that may be present on leads can cause electrical shock.
-

Section 1 Introduction

1.1 Using this manual

The sections in this manual provide information on installing, operating, and maintaining the Rosemount™ 3051 Pressure Transmitter. The sections are organized as follows:

[Section 2: Configuration](#) contains mechanical and electrical installation instructions, and field upgrade options.

[Section 3: Installation](#) provides instruction on commissioning and operating Rosemount 3051 transmitters. Information on software functions, configuration parameters, and online variables is also included.

[Section 4: Operation and Maintenance](#) contains operation and maintenance techniques.

[Section 5: Troubleshooting](#) provides troubleshooting techniques for the most common operating problems.

[Appendix A: Specifications and Reference Data](#) supplies reference and specification data, as well as ordering information.

[Appendix B: Product Certifications](#) contains intrinsic safety approval information, European ATEX directive information, and approval drawings.

1.2 Models covered

The following transmitters are covered by this manual:

Rosemount 3051C Coplanar™ pressure Transmitter

- Rosemount 3051CD Differential Pressure Transmitter
 - Measures differential pressure up to 2000 psi (137,9 bar).
- Rosemount 3051CG Gage Pressure Transmitter
 - Measures gage pressure up to 2000 psi (137,9 bar).
- Rosemount 3051CA Absolute Pressure Transmitter
 - Measures absolute pressure up to 4000 psia (275,8 bar).

Rosemount 3051T In-Line pressure Transmitter

- Rosemount 3051T Gage and Absolute Pressure Transmitter
 - Measures gage pressure up to 10000 psi (689,5 bar).

Rosemount 3051L Liquid Level Transmitter

- Provides precise level and specific gravity measurements up to 300 psi (20,7 bar) for a wide variety of tank configurations.

Note

For transmitters with FOUNDATION™ Fieldbus, see Rosemount 3051 [Reference Manual](#).
For transmitters with PROFIBUS® PA, see Rosemount 3051 [Reference Manual](#).

1.3 Product recycling/ disposal

Recycling of equipment and packaging should be taken into consideration and disposed of in accordance with local and national legislation/regulations.

Section 2 Configuration

Overview	page 3
Safety messages	page 3
Commissioning	page 4
Configuration data review	page 6
Field Communicator menu trees	page 8
Traditional Fast Key sequence	page 12
Check output	page 14
Basic setup	page 15
LCD display	page 21
Detailed setup	page 23
Diagnostics and service	page 24
Advanced functions	page 26
Multidrop communication	page 29

2.1 Overview

This section contains information on commissioning and tasks that should be performed on the bench prior to installation.

Field Communicator and AMS Device Manager instructions are given to perform configuration functions. For convenience, Field Communicator Fast Key sequences are labeled “Fast Keys” for each software function below the appropriate headings.

2.2 Safety messages

Procedures and instructions in this section may require special precautions to ensure the safety of the personnel performing the operations. Information that raises potential safety issues is indicated by a warning symbol (⚠). Refer to the following safety messages before performing an operation preceded by this symbol.

⚠ WARNING

Explosions could result in death or serious injury.

Installation of this transmitter in an explosive environment must be in accordance with the appropriate local, national, and international standards, codes, and practices. Review the approvals section of this manual for any restrictions associated with a safe installation.

- Before connecting a Field Communicator in an explosive atmosphere, ensure the instruments in the loop are installed in accordance with intrinsically safe or non-incendive field wiring practices.
- In an explosion-proof/flameproof installation, do not remove the transmitter covers when power is applied to the unit.

Process leaks may cause harm or result in death.

- Install and tighten process connectors before applying pressure.

Electrical shock can result in death or serious injury.

- Avoid contact with the leads and terminals. High voltage that may be present on leads can cause electrical shock.

2.3 Commissioning

Commissioning consists of testing the transmitter and verifying transmitter configuration data. The Rosemount™ 3051 Pressure Transmitters can be commissioned either before or after installation. Commissioning the transmitter on the bench before installation using a Field Communicator or AMS Device Manager ensures that all transmitter components are in working order.

⚠ To commission on the bench, required equipment includes a power supply, a milliamp meter, and a Field Communicator or AMS Device Manager. Wire equipment as shown in [Figure 2-1](#) and [Figure 2-2](#). To ensure successful communication, a resistance of at least 250 ohms must be present between the Field Communicator loop connection and the power supply. Connect the Field Communicator leads to the terminals labeled “COMM” on the terminal block.

Set all transmitter hardware adjustments during commissioning to avoid exposing the transmitter electronics to the plant environment after installation.

When using a Field Communicator, any configuration changes made must be sent to the transmitter by using the Send key. AMS Device Manager configuration changes are implemented when the Apply button is clicked.

2.3.1 Setting the loop to manual

Whenever sending or requesting data that would disrupt the loop or change the output of the transmitter, set the process application loop to manual. The Field Communicator or AMS Device Manager will prompt you to set the loop to manual when necessary. Acknowledging this prompt does not set the loop to manual. The prompt is only a reminder; set the loop to manual as a separate operation.

2.3.2 Wiring diagrams

Connect the equipment as shown in [Figure 2-1](#) for 4–20 mA HART® or [Figure 2-2](#) for 1-5 Vdc HART Low Power. To ensure successful communication, a resistance of at least 250 ohms must be present between the Field Communicator loop connection and the power supply. The Field Communicator or AMS Device Manager may be connected at “COMM” on the transmitter terminal block or across the load resistor.

Connecting across the “TEST” terminals will prevent successful communication for 4–20 mA HART output.

Turn on the Field Communicator by pressing the ON/OFF key or log into AMS Device Manager. The Field Communicator or AMS Device Manager will search for a HART-compatible device and indicate when the connection is made. If the Field Communicator or AMS Device Manager fail to connect, it indicates that no device was found. If this occurs, refer to [Section 5: Troubleshooting](#).

Figure 2-1. Wiring (4–20 mA)

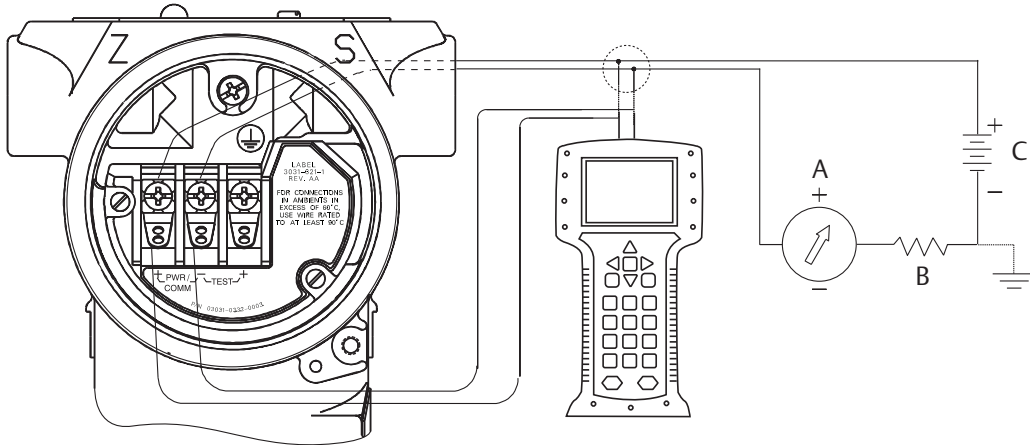

- A. Current meter
- B. $R_t \geq 250 \Omega$
- C. 24 Vdc supply

Figure 2-2. Wiring (Low-Power)

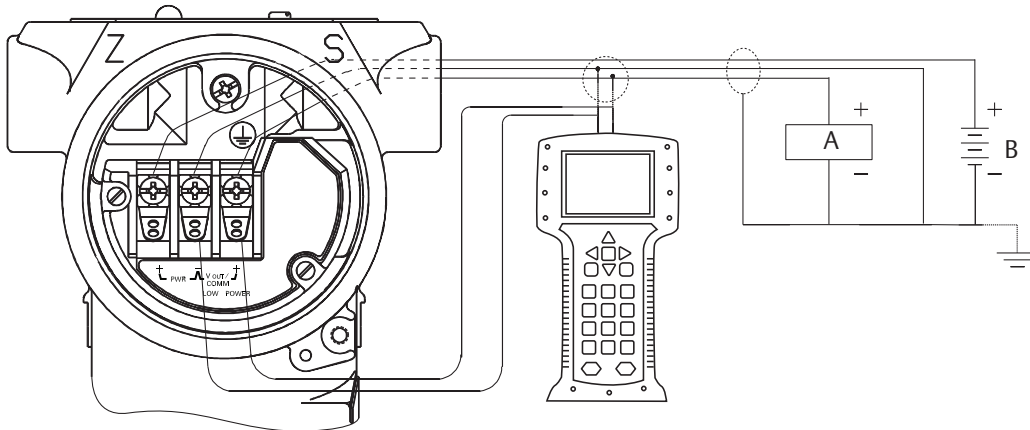

- A. Voltmeter
- B. 6 - 14 Vdc supply

2.4 Configuration data review

Note

Information and procedures in this section that make use of Field Communicator Fast Key sequences and AMS Device Manager assume that the transmitter and communication equipment are connected, powered, and operating correctly.

The following is a list of factory default configurations. These can be reviewed by using the Field Communicator or AMS Device Manager.

Field Communicator

Traditional 4–20 mA Fast Keys	1, 5
Traditional 1–5 Vdc Fast Keys	1, 5
Device Dashboard Fast Keys	1, 7

Enter the Fast Key sequence to view the configuration data.

Transmitter model	Type
Tag	Range
Date	Descriptor
Message	Minimum and maximum sensor limits
Minimum span	Units
4 and 20 mA points	Output (linear or sq. root)
Damping	Alarm setting (high, low)
Security setting (on, off)	Local zero/span keys (enabled, disabled)
Integral display	Sensor fill
Isolator material	Flange (type, material)
O-ring material	Drain/Vent
Remote seal (type, fill fluid, isolator material, number)	Transmitter S/N
Address	Sensor S/N

AMS Device Manager

Right click on the device and select **Configuration Properties** from the menu. Select the tabs to review the transmitter configuration data.

2.5 Field Communicator

(Version 1.8)

2.5.1 Field Communicator user interface

Figure 2-3. Traditional Interface

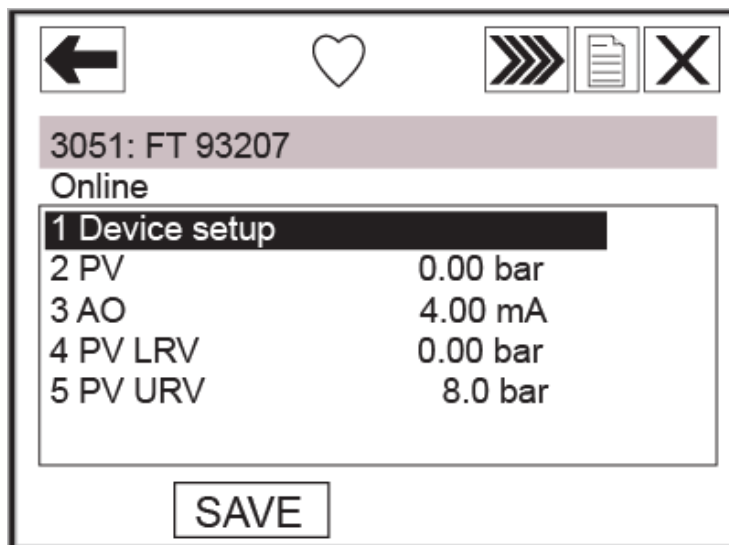

The corresponding menu trees can be viewed on [page 8](#) and [page 9](#).

The Fast Key sequence can be viewed on [page 12](#).

Figure 2-4. Device Dashboard

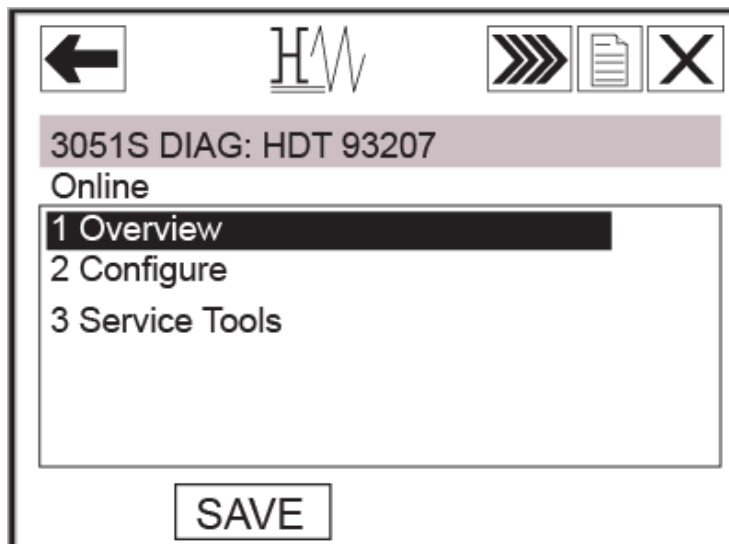

The corresponding menu trees can be viewed on [page 10](#) through [page 12](#).

The Fast Key sequence can be viewed on [page 14](#).

2.6 Field Communicator menu trees

Figure 2-5. Rosemount 3051 Traditional HART Menu Tree For 4-20 Ma HART Output

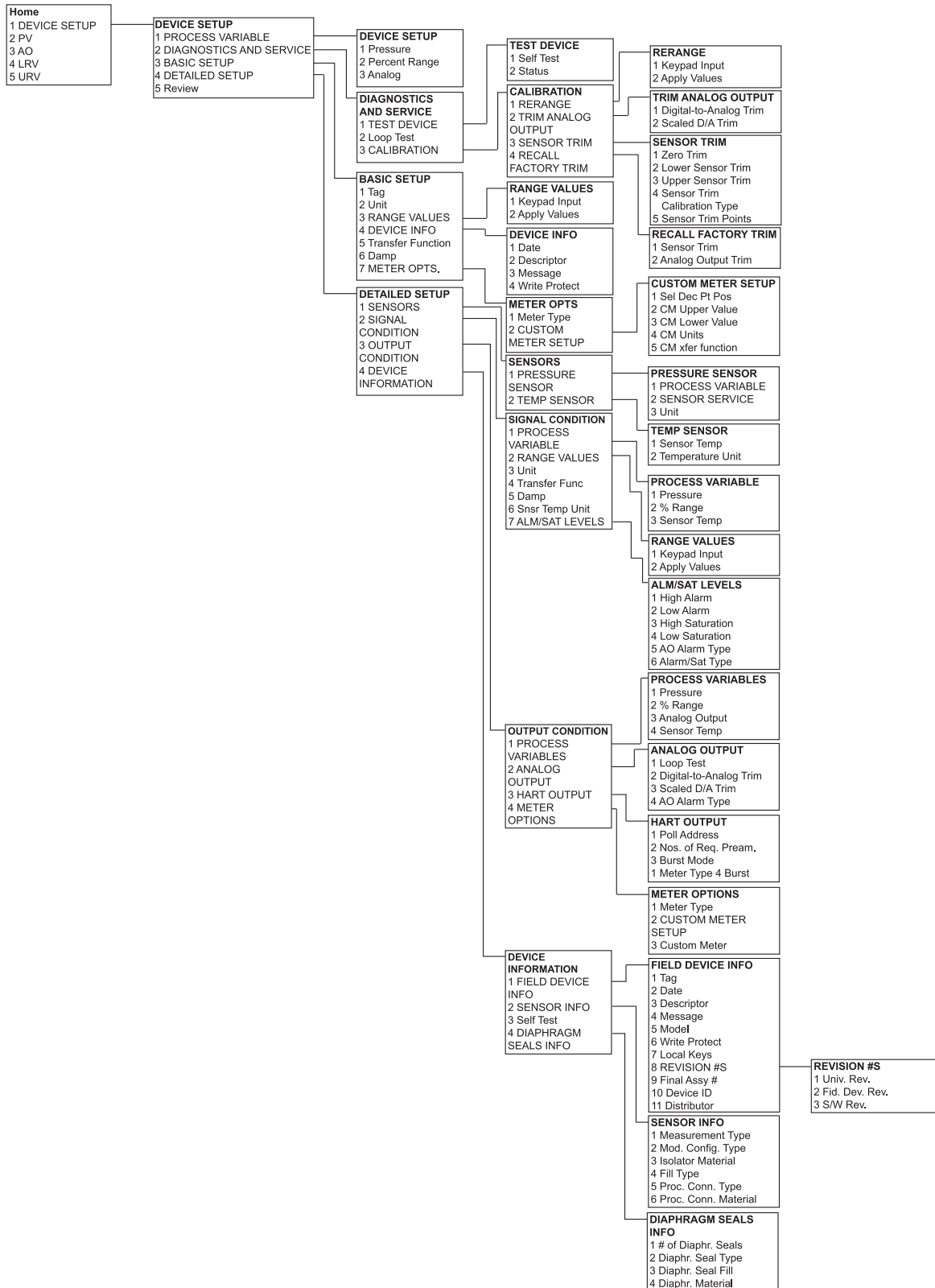

Figure 2-6. Rosemount 3051 Traditional HART Menu Tree for 1-5 Vdc Low Power

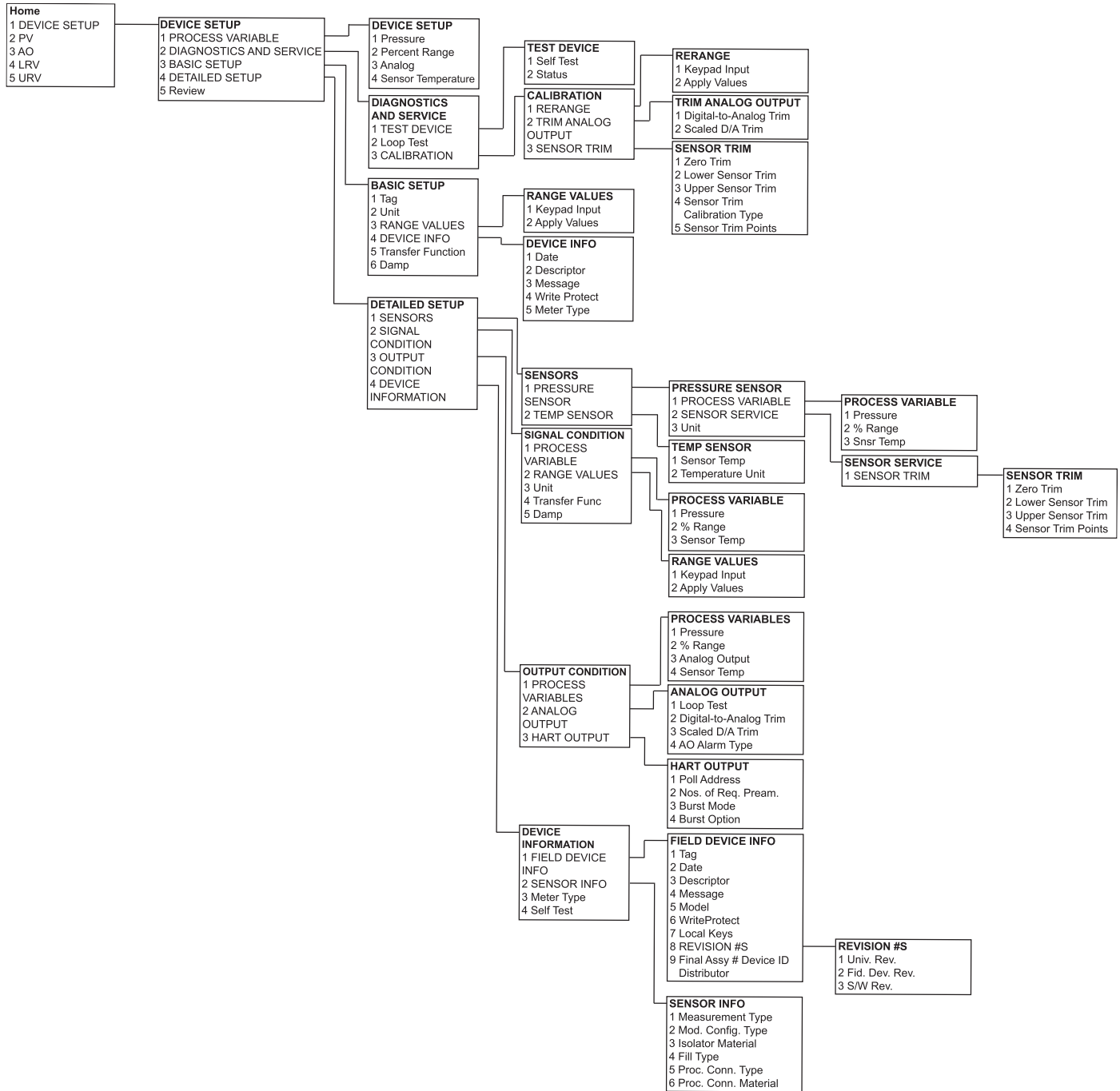

Figure 2-7. Overview

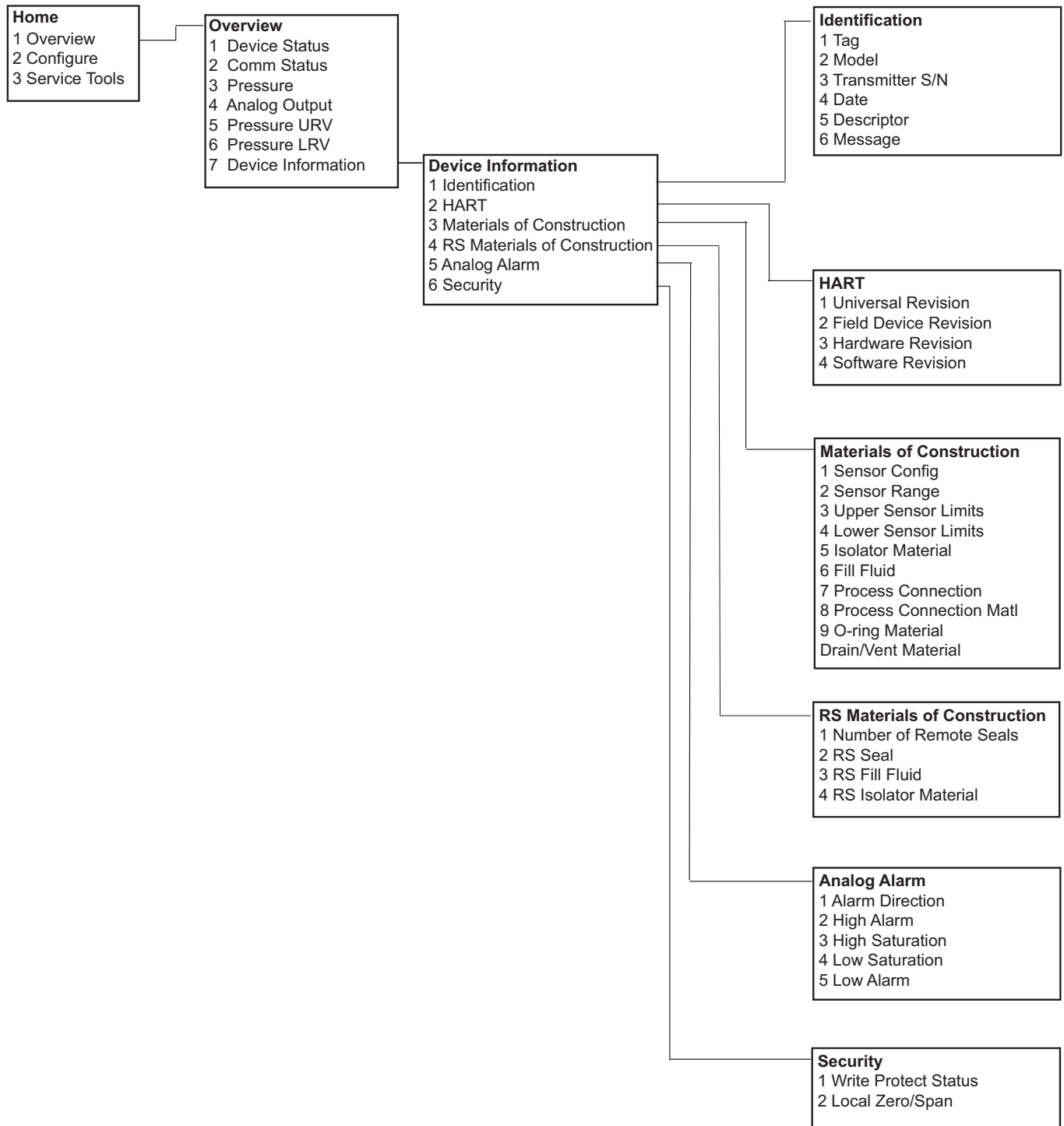

Figure 2-8. Configure

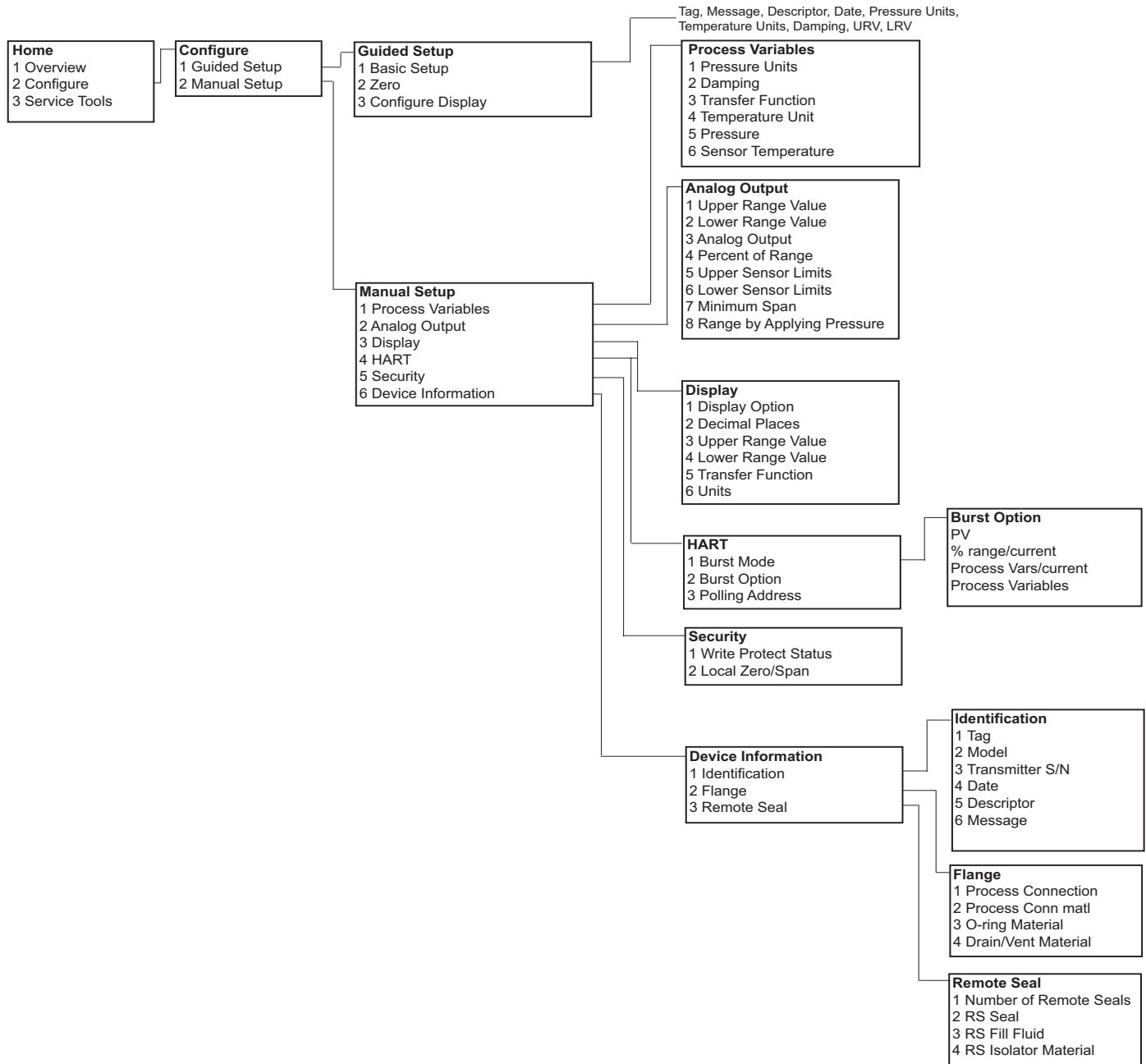
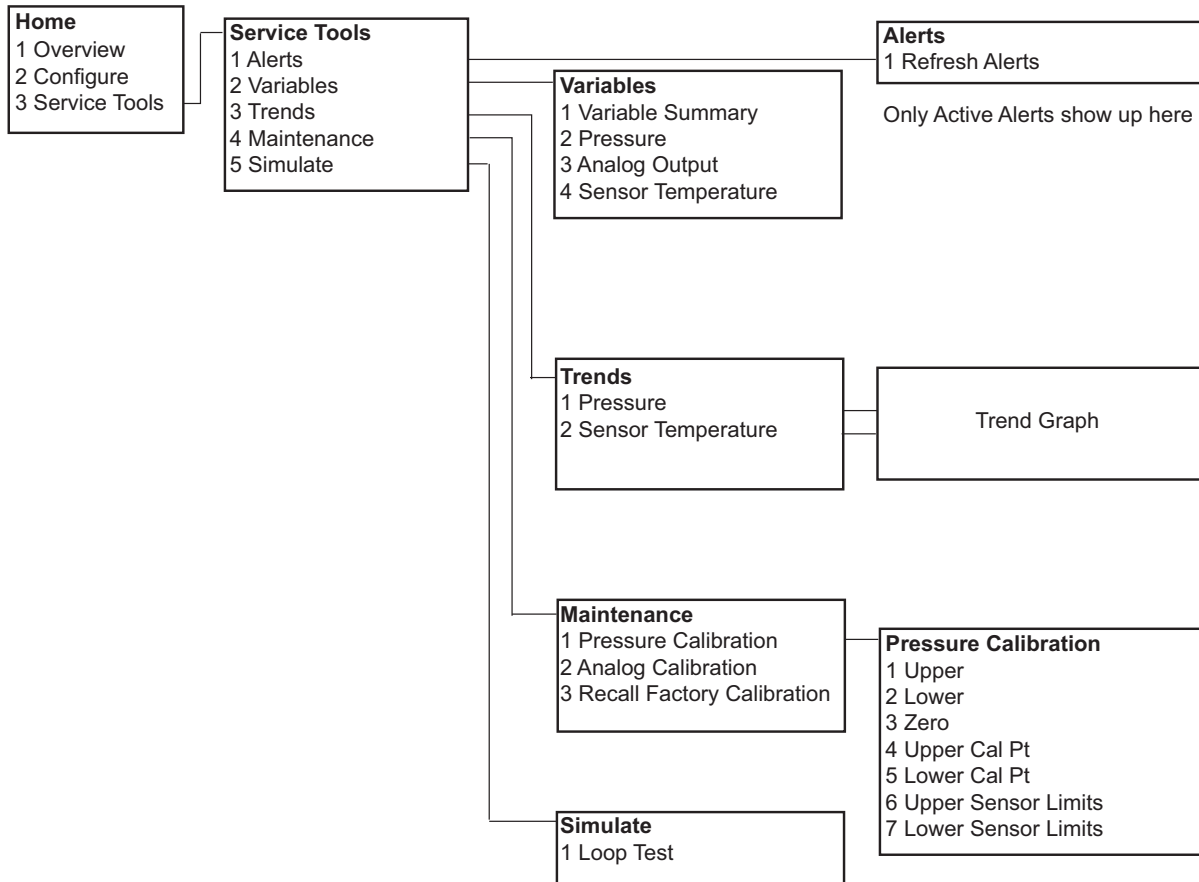

Figure 2-9. Service Tools



2.7 Traditional Fast Key sequence

A check (✓) indicates the basic configuration parameters. At minimum, these parameters should be verified as part of the configuration and startup procedure.

Table 2-1. Traditional Fast Key Sequence

Function	4–20 mA HART	1–5 Vdc HART low power
✓ Alarm and Saturation Levels	1, 4, 2, 7	N/A
Analog Output Alarm Type	1, 4, 3, 2, 4	1, 4, 3, 2, 4
Burst Mode Control	1, 4, 3, 3, 3	1, 4, 3, 3, 3
Burst Operation	1, 4, 3, 3, 4	1, 4, 3, 3, 4
Custom Meter Configuration	1, 3, 7, 2	N/A
Custom Meter Value	1, 4, 3, 4, 3	N/A
✓ Damping	1, 3, 6	1, 3, 6
Date	1, 3, 4, 1	1, 3, 4, 1
Descriptor	1, 3, 4, 2	1, 3, 4, 2

Table 2-1. Traditional Fast Key Sequence

Function	4–20 mA HART	1–5 Vdc HART low power
Digital To Analog Trim (4-20 mA Output)	1, 2, 3, 2, 1	1, 2, 3, 2, 1
Disable Local Span/Zero Adjustment	1, 4, 4, 1, 7	1, 4, 4, 1, 7
Field Device Information	1, 4, 4, 1	1, 4, 4, 1
Full Trim	1, 2, 3, 3	1, 2, 3, 3
Keypad Input – Rerange	1, 2, 3, 1, 1	1, 2, 3, 1, 1
Local Zero and Span Control	1, 4, 4, 1, 7	1, 4, 4, 1, 7
Loop Test	1, 2, 2	1, 2, 2
Lower Sensor Trim	1, 2, 3, 3, 2	1, 2, 3, 3, 2
Message	1, 3, 4, 3	1, 3, 4, 3
Meter Options	1, 4, 3, 4	N/A
Number of Requested Preambles	1, 4, 3, 3, 2	1, 4, 3, 3, 2
Poll Address	1, 4, 3, 3, 1	1, 4, 3, 3, 1
Poll a Multidropped Transmitter	Left Arrow, 4, 1, 1	Left Arrow, 4, 1, 1
√ Range Values	1, 3, 3	1, 3, 3
Rerange	1, 2, 3, 1	1, 2, 3, 1
Scaled D/A Trim (4–20 mA Output)	1, 2, 3, 2, 2	1, 2, 3, 2, 2
Self Test (Transmitter)	1, 2, 1, 1	1, 2, 1, 1
Sensor Info	1, 4, 4, 2	1, 4, 4, 2
Sensor Temperature	1, 1, 4	1, 1, 4
Sensor Trim Points	1, 2, 3, 3, 4	1, 2, 3, 3, 4
Status	1, 2, 1, 2	1, 2, 1, 2
√ Tag	1, 3, 1	1, 3, 1
√ Transfer Function (Setting Output Type)	1, 3, 5	1, 3, 5
Transmitter Security (Write Protect)	1, 3, 4, 4	1, 3, 4, 4
Trim Analog Output	1, 2, 3, 2	1, 2, 3, 2
√ Units (Process Variable)	1, 3, 2	1, 3, 2
Upper Sensor Trim	1, 2, 3, 3, 3	1, 2, 3, 3, 3
Zero Trim	1, 2, 3, 3, 1	1, 2, 3, 3, 1

Table 2-2. Device Dashboard Fast Key Sequence

Function	4–20 mA HART
Alarm and saturation levels	1, 7, 5
Analog output alarm type	1, 7, 5
Burst mode control	2, 2, 4, 1
Burst option	2, 2, 4, 2
Custom display configuration	2, 2, 3
Damping	2, 2, 1, 2
Date	2, 2, 6, 1, 4
Descriptor	2, 2, 6, 1, 5
Digital to analog trim (4 - 20 mA output)	3, 4, 2
Disable zero and span adjustment	2, 2, 5, 2
Field device information	2, 2, 6
Loop test	3, 5, 1
Lower sensor trim	3, 4, 1, 2
Message	2, 2, 6, 1, 6
Poll address	2, 2, 4, 3
Range values	1, 5
Rerange with keypad	1, 5
Scaled D/A trim (4–20 mA output)	3, 4, 2
Sensor temperature/trend	3, 3, 2
Tag	2, 2, 6, 1, 1
Transfer function	2, 2, 1, 3
Transmitter security (write protect)	2, 2, 5, 1
Units	2, 2, 1, 1
Upper sensor trim	3, 4, 1, 1
Zero trim	3, 4, 1, 3

2.8 Check output

Before performing other transmitter on-line operations, review the digital output parameters to ensure that the transmitter is operating properly and is configured to the appropriate process variables.

2.8.1 Process variables

The process variables for the Rosemount 3051 provide transmitter output, and are continuously updated. The pressure reading in both engineering units and percent of range will continue to track with pressures outside of the defined range from the lower to the upper range limit of the sensor module.

Field Communicator

Traditional 4–20 mA Fast Keys	1, 1
Traditional 1–5 Vdc Fast Keys	1, 1
Device Dashboard Fast Keys	3, 2

The process variable menu displays the following process variables:

- Pressure
- Percent of range
- Analog output

AMS Device Manager

Right click on the device and select **Process Variables...** from the menu. The *Process Variable* screen displays the following process variables:

- Pressure
- Percent of range
- Analog output

2.8.2 Sensor temperature

The Rosemount 3051 contains a temperature sensor near the pressure sensor in the sensor module. When reading this temperature, keep in mind the sensor is not a process temperature reading.

Field Communicator

Traditional 4–20 mA Fast Keys	1, 1, 4
Traditional 1–5 Vdc Fast Keys	1, 1, 4
Device Dashboard Fast Keys	3, 2, 4

Enter the Fast Key sequence “Sensor Temperature” to view the sensor temperature reading.

AMS Device Manager

Right click on the device and select **Process Variables...** from the menu. *Snsr Temp* is the sensor temperature reading.

2.9 Basic setup

2.9.1 Set process variable units

The *PV Unit* command sets the process variable units to allow you to monitor your process using the appropriate units of measure.

Field Communicator

Traditional 4–20 mA Fast Keys	1, 3, 2
Traditional 1–5 Vdc Fast Keys	1, 3, 2
Device Dashboard Fast Keys	2, 2, 1, 1

Enter the Fast Key sequence “Set Process Variable Units.” Select from the following engineering units:

- inH₂O
- inHg
- ftH₂O
- mmH₂O
- mmHg
- psi
- bar
- mbar
- g/cm²
- kg/cm²
- Pa
- kPa
- torr
- atm
- inH₂O at 4 °C
- mmH₂O at 4 °C

AMS Device Manager

Right click on the device and select **Configure** from the menu. In the *Basic Setup* tab, select **Unit** from the drop down menu to select units.

2.9.2 Set output (transfer function)

The Rosemount 3051 has two output settings: linear and square root. Activate the square root output option to make analog output proportional to flow. As input approaches zero, the Rosemount 3051 automatically switches to linear output in order to ensure a more smooth, stable output near zero (see Figure 2-10).

For 4–20 mA HART output, the slope of the curve is unity ($y = x$) from 0 to 0.6 percent of the ranged pressure input. This allows accurate calibration near zero. Greater slopes would cause large changes in output (for small changes at input). From 0.6 to 0.8 percent, curve slope equals 42 ($y = 42x$) to achieve continuous transition from linear to square root at the transition point.

Field Communicator

Traditional 4–20 mA Fast Keys	1, 3, 5
Traditional 1–5 Vdc Fast Keys	1, 3, 5
Device Dashboard Fast Keys	2, 2, 1, 3

AMS Device Manager

1. Right click on the device and select **Configure** from the menu.
2. In the *Basic Setup* tab, use Xfer fnctn drop down menu to select output, click **Apply**.
3. After carefully reading the warning provided, select **yes**.

Figure 2-10. 4-20 mA HART Square Root Output Transition Point

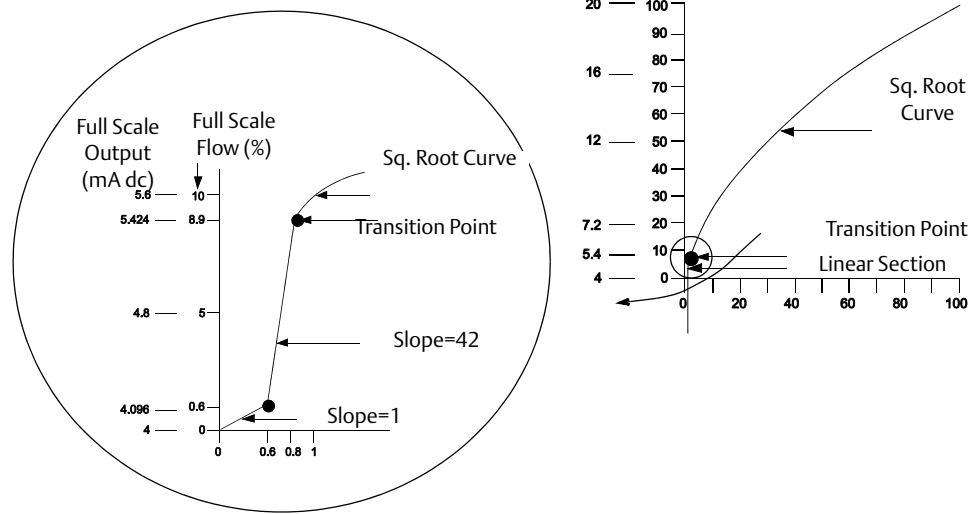

Note

For a flow turndown of greater than 10:1 it is not recommended to perform a square root extraction in the transmitter. Instead, perform the square root extraction in the system.

2.9.3

Rerange

The *Range Values* command sets each of the lower and upper range analog values (4 and 20 mA points and 1 and 5 Vdc points) to a pressure. The lower range point represents 0 percent of range and the upper range point represents 100 percent of range. In practice, the transmitter range values may be changed as often as necessary to reflect changing process requirements. For a complete listing of range & sensor limits, refer to “[Range and sensor limits](#)” on page 93.

Note

Transmitters are shipped from Emerson™ fully calibrated per request or by the factory default of full scale (zero to upper range limit).

Note

Regardless of the range points, the Rosemount 3051 will measure and report all readings within the digital limits of the sensor. For example, if the 4 and 20 mA points are set to 0 and 10 inH₂O, and the transmitter detects a pressure of 25 inH₂O, it digitally outputs the 25 inH₂O reading and a 250% of range reading.

Select from one of the methods below to rerange the transmitter. Each method is unique; examine all options closely before deciding which method works best for your process.

- Rerange with a Field Communicator or AMS Device Manager only.
- Rerange with a pressure input source and a Field Communicator or AMS Device Manager.
- Rerange with a pressure input source and the local zero and span buttons (option D4).

Note

If the transmitter security switch is **ON**, adjustments to the zero and span will not be able to be made. Refer to “Configure security and alarm” on page 44 for security information.

Rerange with a Field Communicator or AMS Device Manager only.

The easiest and most popular way to rerange is to use the Field Communicator only. This method changes the range values of the analog 4 and 20 mA points (1 and 5 Vdc points) independently without a pressure input. This means that when you change either the 4 or 20 mA setting, you also change the span.

An example for the 4–20 mA HART output:

If the transmitter is ranged so that

4 mA = 0 inH₂O, and
20 mA = 100 inH₂O,

and you change the 4 mA setting to 50 inH₂O using the communicator only, the new settings are:

4 mA = 50 inH₂O, and
20 mA = 100 inH₂O.

Note that the span was also changed from 100 inH₂O to 50 inH₂O, while the 20 mA setpoint remained at 100 inH₂O.

To obtain reverse output, simply set the 4 mA point at a greater numerical value than the 20 mA point. Using the above example, setting the 4 mA point at 100 inH₂O and the 20 mA point at 0 inH₂O will result in reverse output.

Field Communicator

Traditional 4-20 mA Fast Keys	1, 2, 3, 1
Traditional 1-5 Vdc Fast Keys	1, 2, 3, 1
Device Dashboard Fast Keys	2, 2, 2, 1

From the *HOME* screen, enter the Fast Key sequence “Rerange with a Communicator Only.”

AMS Device Manager

Right click on the device and select **Configure** from the menu. In the *Basic Setup* tab, locate the Analog Output box and perform the following procedure:

1. Enter the lower range value (LRV) and the upper range value (URV) in the fields provided. Select **Apply**.
2. After carefully reading the warning provided, select **yes**.

Rerange with a pressure input source and a Field Communicator or AMS Device Manager

Reranging using the Field Communicator and applied pressure is a way of reranging the transmitter when specific 4 and 20 mA points (1 and 5 Vdc points) are not calculated.

Note

The span is maintained when the 4 mA point (1 Vdc point) is set. The span changes when the 20 mA point (5 Vdc point) is set. If the lower range point is set to a value that causes the upper range point to exceed the sensor limit, the upper range point is automatically set to the sensor limit, and the span is adjusted accordingly.

Field Communicator

Traditional 4–20 mA Fast Keys	1, 2, 3, 1, 2
Traditional 1–5 Vdc Fast Keys	1, 2, 3, 1, 2
Device Dashboard Fast Keys	2, 2, 2, 8

From the *HOME* screen, enter the Fast Key sequence [Rerange with a pressure input source and a Field Communicator](#) or [AMS Device Manager](#) .

AMS Device Manager

1. Right click on the device, select **Calibrate**, then **Apply** values from the menu.
2. Select **Next** after the control loop is set to manual.
3. From the *Apply Values* menu, follow the on-line instructions to configure lower and upper range values.
4. Select **Exit** to leave the *Apply Values* screen.
5. Select **Next** to acknowledge the loop can be returned to automatic control.
6. Select **Finish** to acknowledge the method is complete.

Rerange with a pressure input source and the local zero and span buttons (option D4)

Reranging using the local zero and span adjustments (see [Figure 2-11 on page 20](#)) and a pressure source is a way of reranging the transmitter when specific 4 and 20 mA (1 and 5 Vdc) points are not known and a communicator is not available.

Note

When you set the 4 mA (1 Vdc) point the span is maintained; when you set the 20 mA (5 Vdc) point the span changes. If you set the lower range point to a value that causes the upper range point to exceed the sensor limit, the upper range point is automatically set to the sensor limit, and the span is adjusted accordingly.

To rerange the transmitter using the span and zero buttons, perform the following procedure:

1. Loosen the screw holding the certifications label on the top of the transmitter housing. Slide the label to expose the zero and span buttons. See [Figure 2-11](#).
2. Apply the desired 4 mA (1 Vdc) pressure value to the transmitter. Push and hold the zero adjustment button for at least two seconds but no longer than 10 seconds.
3. Apply the desired 20 mA (5 Vdc) pressure value to the transmitter. Push and hold the span adjustment button for at least two seconds but no longer than 10 seconds.

Figure 2-11. Zero and Span Button

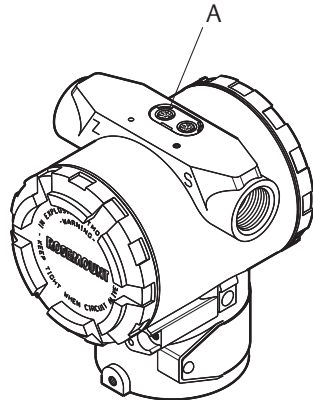

A. Span and zero adjustment buttons

Note

The span is maintained when the 4 mA point (1 Vdc point) is set. The span changes when the 20 mA point (5 Vdc point) is set. If the lower range point is set to a value that causes the upper range point to exceed the sensor limit, the upper range point is automatically set to the sensor limit, and the span is adjusted accordingly.

2.9.4

Damping

The “Damp” command introduces a delay in the micro-processing which increases the response time of the transmitter; smoothing variations in output readings caused by rapid input changes. Determine the appropriate damping setting based on the necessary response time, signal stability, and other requirements of the loop dynamics within your system. The default damping value is 0.4 seconds and it can be set to any of ten pre-configured damping values between 0 and 25.6 seconds. See list below.

- 0.00 second
- 0.05 second
- 0.10 second
- 0.20 second
- 0.40 second
- 0.80 second
- 1.60 seconds
- 3.20 seconds
- 6.40 seconds
- 12.8 seconds
- 25.6 seconds

The current damping value can be determined by executing the Field Communicator Fast Keys or going to *Configure* in AMS Device Manager.

Field Communicator

Traditional 4–20 mA Fast Keys	1, 3, 6
Traditional 1–5 Vdc Fast Keys	1, 3, 6
Device Dashboard Fast Keys	2, 2, 1, 2

AMS Device Manager

1. Right click on the device and select **Configure** from the menu.
2. In the *Basic Setup* tab, enter the damping value in the *Damp* field, select **Apply**.
3. After carefully reading the warning provided, select **yes**.

2.10 LCD display

The LCD display connects directly to the interface board which maintains direct access to the signal terminals. The display indicates output and abbreviated diagnostic messages. A display cover is provided to accommodate the display.

For 4–20 mA HART output, the LCD display features a two-line display. The first line of five characters displays the actual measured value, the second line of six characters displays the engineering units. The LCD display can also show diagnostic messages. Refer to [Figure 2-12](#).

For 1–5 Vdc HART Low Power output, the LCD display features a single-line display with four characters that display the actual value. The LCD display can also show diagnostic messages. Refer to [Figure 2-12](#).

Figure 2-12. LCD Display

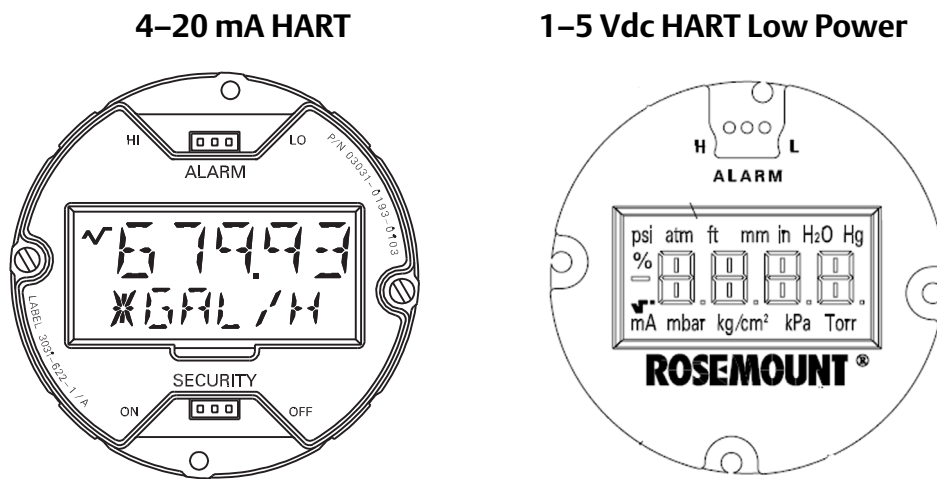

2.10.1 LCD display configuration for 4–20 mA HART only

The factory default alternates are between Engineering Units and % of Range. The LCD Display Configuration command allows customization of the LCD display to suit application requirements. The LCD display will alternate between the selected items

- Eng. Units only
- % of Range only
- Custom Display only
- Alternate Eng. Units and % of Range
- Alternate Eng. Units and Custom Display
- Alternate % of Range and Custom Display

Field Communicator

Traditional 4-20 mA Fast Keys	1, 3, 7
Device Dashboard Fast Keys	2, 2, 3

To change the standard default to one of the above options, follow these steps:

1. From the communicators main menu select **1: Device Setup, 3: Basic Setup, 7: Meter Options.**
2. Select **1: Meter Type.** Using the up or down arrows scroll up or down until the desired display has been highlighted. Press **ENTER, SEND, and HOME.**

AMS Device Manager

1. Right click on the device and select **Configuration Properties** from the menu.
2. In the *Local Display* tab, locate the *Meter Type* area. Select the desired options to suit your application needs, select **Apply**.
3. An *Apply Parameter Modification* screen appears, enter desired information and select **OK**.
4. After carefully reading the warning provided, select **OK**.

2.10.2 Custom display configuration 4–20 mA HART only

The user-configurable scale is a feature that enables the LCD display to show flow, level, or custom pressure units. With this feature you can define the decimal point position, the upper range value, the lower range value, the engineering units, and the transfer function. The display can be configured using a Field Communicator or AMS Device Manager.

The user-configurable scale feature can define:

- decimal point position
- upper range values
- lower range values
- engineering units
- transfer function

To configure the display with a Field Communicator, perform the following procedure:

1. Change the Meter Type to “Custom Meter” by using the Fast Key sequence under “[LCD display configuration for 4–20 mA HART only](#)” on page 21.
2. Next from the *ONLINE* screen, Select **1: Device Setup, 3: Basic Setup, 7: Meter Options, 2: Meter Options, 2: Custom Meter Setup**.
3. To specify decimal point position:
 - a. Select **1: Sel dec pt pos**. Select the decimal point representation that will provide the most accurate output for your application. For example, when outputting between zero and 75 GPM, select XX.XXX or use the decimal point examples below:

XXXXX
XXXX.X
XXX.XX
XX.XXX
X.XXXX

Note

Make sure the selection has been sent and the decimal point has changed before proceeding to the next step.

- b. Select **SEND**.
4. To specify a custom upper range value:
 - a. Select **2: CM Upper Value**. Type the value that you want the transmitter to read at the 20 mA point.
 - b. Select **SEND**.

 See “[Safety messages](#)” on page 3 for complete warning information.

5. To specify a custom lower range value:
 - a. Select **3: CM Lower Value**. Type the value that you want the transmitter to read at the 4 mA point.
 - b. Select **SEND**.
6. To define custom units:
 - a. Select **4: CM Units**. Enter the custom units (five characters maximum) to show on LCD display.
 - b. Select **SEND**.
7. To select the transmitter transfer function for the display:
 - a. Select **5: CM xfer fnct**. Enter the transmitter transfer function for the display. Select **sq root** to display flow units. The custom meter transfer function is independent of the analog output transfer function.
8. Select **SEND** to upload the configuration to the transmitter.

2.11 Detailed setup

2.11.1 Failure mode alarm and saturation

The Rosemount 3051 Transmitters automatically and continuously perform self-diagnostic routines. If the self-diagnostic routines detect a failure, the transmitter drives its output outside of the normal saturation values. The transmitter will drive its output low or high based on the position of the failure mode alarm jumper. See [Table 2-3](#), [Table 2-4](#), and [Table 2-5](#) for failure mode and saturation output levels. To select alarm position, see “Configure security and alarm” on page 44.

Table 2-3. 4–20 mA HART Alarm and Saturation Values

Level	4–20 mA saturation	4–20 mA alarm
Low	3.9 mA	≤ 3.75 mA
High	20.8 mA	≥ 21.75 mA

Table 2-4. NAMUR-Compliant Alarm and Saturation Values

Level	4–20 mA saturation	4–20 mA alarm
Low	3.8 mA	≤ 3.6 mA
High	20.5 mA	≥ 22.5 mA

Table 2-5. 1–5 Vdc HART Low-Power Alarm and Saturation Values

Level	1–5 V saturation	1–5 V alarm
Low	0.97 V	≤ 0.95 V
High	5.20 V	≥ 5.4 V

⚠ CAUTION

Alarm level values will be affected by analog trim. Refer to “Digital-to-Analog trim” on page 69.

Note

When a transmitter is in an alarm condition, the Field Communicator indicates the analog output the transmitter would drive if the alarm condition did not exist. The transmitter will alarm high in the event of failure if the alarm jumper is removed.

2.11.2 Alarm and saturation levels for burst mode

Transmitters set to burst mode handle saturation and alarm conditions differently.

Alarm conditions

- Analog output switches to alarm value.
- Primary variable is burst with a status bit set.
- Percent of range follows primary variable .
- Temperature is burst with a status bit set.

Saturation

- Analog output switches to saturation value.
- Primary variable is burst normally.
- Temperature is burst normally.

2.11.3 Alarm and saturation values for multidrop mode

Transmitters set to multidrop mode handle saturation and alarm conditions differently.

Alarm conditions

- Primary variable is sent with a status bit set.
- Percent of range follows primary variable .
- Temperature is sent with a status bit set.

Saturation

- Primary variable is sent normally.
- Temperature is sent normally.

2.11.4 Alarm level verification

If the transmitter electronics board, sensor module, or LCD display is repaired or replaced, verify the transmitter alarm level before returning the transmitter to service. This feature is also useful in testing the reaction of the control system to a transmitter in an alarm state. To verify the transmitter alarm values, perform a loop test and set the transmitter output to the alarm value (see Tables 2-3, 2-4, and 2-5 on page 23, and “Loop test” on page 24).

2.12 Diagnostics and service

Diagnostics and service functions listed below are primarily for use after field installation. The Loop Test feature is designed to verify proper loop wiring and transmitter output.

2.12.1 Loop test

The loop test command verifies the output of the transmitter, the integrity of the loop, and the operations of any recorders or similar devices installed in the loop.

Field Communicator

Traditional 4–20 mA Fast Keys	1, 2, 2
Traditional 1–5 Vdc Fast Keys	1, 2, 2
Device Dashboard Fast Keys	3, 5, 1

To initiate a loop test, perform the following procedure:

1. For 4–20 mA HART output, connect a reference meter to the transmitter by either connecting the meter to the test terminals on the terminal block, or shunting transmitter power through the meter at some point in the loop.

For 1–5 Vdc Low Power HART output, connect a reference meter to the V_{out} terminal.

2. From the *HOME* screen, enter the Fast Key sequence “Loop Test” to verify the output of the transmitter.
3. Select **OK** after the control loop is set to manual (see “Setting the loop to manual” on page 4).
4. Select a discrete milliamp level for the transmitter to output. At the *CHOOSE ANALOG OUTPUT* prompt select **1: 4mA (1 Vdc)**, select **2: 20mA (5 Vdc)**, or select **3: “Other”** to manually input a value.
 - a. If you are performing a loop test to verify the output of a transmitter, enter a value between 4 and 20 mA (1 and 5 Vdc).
 - b. If you are performing a loop test to verify alarm levels, enter the value representing an alarm state (see Tables 2-3, 2-4, and 2-5 on page 23).
5. Check that the reference meter displays the commanded output value.
 - a. If the values match, the transmitter and the loop are configured and functioning properly.
 - b. If the values do not match, the meter may be attached to the wrong loop, there may be a fault in the wiring or power supply, the transmitter may require an output trim, or the reference meter may be malfunctioning.

After completing the test procedure, the display returns to the *Loop Test* screen to select another output value or to end loop testing.

AMS Device Manager

1. Right click on the device and select **Diagnostics and Test**, then Loop Test from the menu.
2. For 4-20 mA HART output, connect a reference meter to the transmitter by either connecting the meter to the test terminals on the terminal block, or shunting transmitter power through the meter at some point in the loop.

For 1-5 Vdc Low Power HART output, connect a reference meter to the V_{out} terminal.

3. Select **Next** after setting the control loop to manual.
4. Select desired analog output level. Select **Next**.
5. Select **Next** to acknowledge output being set to desired level.
6. Check that the reference meter displays the commanded output value.
 - a. If the values match, the transmitter and the loop are configured and functioning properly.
 - b. If the values do not match, the meter may be attached to the wrong loop, there may be a fault in the wiring or power supply, the transmitter may require an output trim, or the reference meter may be malfunctioning.

After completing the test procedure, the display returns to the *Loop Test* screen to choose another output value or to end loop testing.

7. Select **End** and click **Next** to end loop testing.
8. Select **Next** to acknowledge the loop can be returned to automatic control.
9. Select **Finish** to acknowledge the method is complete.

2.13 Advanced functions

2.13.1 Saving, recalling, and cloning configuration data

Use the cloning feature of the Field Communicator or the AMS Device Manager “User Configuration” feature to configure several Rosemount 3051 Transmitters similarly. Cloning involves configuring a transmitter, saving the configuration data, then sending a copy of the data to a separate transmitter. Several possible procedures exist when saving, recalling, and cloning configuration data. For complete instructions refer to the Field Communicator [Reference Manual](#) or AMS Device Manager online guides. One common method is as follows:

Field Communicator

Traditional 4–20 mA Fast Keys	left arrow, 1, 2
Traditional 1–5 Vdc Fast Keys	left arrow, 1, 2
Device Dashboard Fast Keys	3, 4, 3

1. Completely configure the first transmitter.
2. Save the configuration data:
 - a. Select **SAVE** from the Field Communicator *HOME/ONLINE* screen.
 - b. Ensure that the location to which the data will be saved is set to MODULE. If it is not, select **1: Location** to set the save location to MODULE.
 - c. Select **2: Name**, to name the configuration data. The default is the transmitter tag number.
 - d. Ensure that the data type is set to STANDARD. If the data type is NOT STANDARD, select **3: Data Type** to set the data type to STANDARD.
 - e. Select **SAVE**.
3. Connect and power the receiving transmitter and Field Communicator.
4. Select the back arrow from the *HOME/ONLINE* screen. The Field Communicator menu appears.
5. Select **1: Offline, 2: Saved Configuration, 1: Module Contents** to reach the *MODULE CONTENTS* menu.
6. Use the **DOWN ARROW** to scroll through the list of configurations in the memory module, and use the **RIGHT ARROW** to select and retrieve the required configuration.
7. Select **1: Edit**.
8. Select **1: Mark All**.
9. Select **Save**.
10. Use the **DOWN ARROW** to scroll through the list of configurations in the memory module, and use the **RIGHT ARROW** to select the **configuration** again.

11. Select **3: Send** to download the configuration to the transmitter.
12. Select **OK** after the control loop is set to manual.
13. After the configuration has been sent, select **OK** to acknowledge that the loop can be returned to automatic control.

When finished, the Field Communicator informs you of the status. Repeat steps 3 through 13 to configure another transmitter.

Note

The transmitter receiving cloned data must have the same software version (or later) as the original transmitter.

AMS Device Manager creating a reusable copy

To create a reusable copy of a configuration perform the following procedure:

1. Completely configure the first transmitter.
2. Select **View** then **User Configuration View** from the menu bar (or click the toolbar button).
3. In the *User Configuration* window, right click and select **New** from the *context* menu.
4. In the *New* window, select a device from the list of templates shown, and select **OK**.
5. The template is copied into the User Configurations window, with the tag name highlighted; rename it as appropriate and press **Enter**.

Note

A device icon can also be copied by dragging and dropping a device template or any other device icon from AMS Device Manager Explorer or Device Connection View into the User Configurations window.

The *Compare Configurations* window appears, showing the current values of the copied device on one side and mostly blank fields on the other (User Configuration) side.

6. Transfer values from the current configuration to the user configuration as appropriate or enter values by typing the values into the available fields.
7. Select **Apply** to apply the values, or select **OK** to apply the values and close the window.

AMS Device Manager applying a user configuration

Any amount of user configurations can be created for the application. They can also be saved, and applied to connected devices or to devices in the device list or plant database.

Note

When using AMS Device Manager Revision 6.0 or later, the device to which the user configuration is applied, must be the same model type as the one created in the user configuration. When using AMS Device Manager Revision 5.0 or earlier, the same model type and revision number are required.

To apply a user configuration perform the following procedure:

1. Select the desired user configuration in the *User Configurations* window.
2. Drag the icon onto a like device in AMS Device Manager Explorer or Device Connection View. The *Compare Configurations* window opens, showing the parameters of the target device on one side and the parameters of the user configuration on the other.
3. Transfer parameters from the user configuration to the target device as desired. Click **OK** to apply the configuration and close the window.

2.13.2 Burst mode

When configured for burst mode, the Rosemount 3051 provides faster digital communication from the transmitter to the control system by eliminating the time required for the control system to request information from the transmitter. Burst mode is compatible with the analog signal. Because the HART protocol features simultaneous digital and analog data transmission, the analog value can drive other equipment in the loop while the control system is receiving the digital information. Burst mode applies only to the transmission of dynamic data (pressure and temperature in engineering units, pressure in percent of range, and/or analog output), and does not affect the way other transmitter data is accessed.

Access to information other than dynamic transmitter data is obtained through the normal poll/response method of HART Communication. A Field Communicator, AMS Device Manager or the control system may request any of the information that is normally available while the transmitter is in burst mode. Between each message sent by the transmitter, a short pause allows the Field Communicator, AMS Device Manager or a control system to initiate a request. The transmitter will receive the request, process the response message, and then continue “bursting” the data approximately three times per second.

Field Communicator

Traditional 4–20 mA Fast Keys	1, 4, 3, 3, 3
Traditional 1–5 Vdc Fast Keys	1, 4, 3, 3, 3
Device Dashboard Fast Keys	2, 2, 4, 1

AMS Device Manager

Right click on the device and select **Configure** from the menu.

1. In the *HART* tab, use the drop down menu to select **“Burst Mode ON or OFF.”** For *“Burst option”* select the desired properties from the drop down menu. Burst options are as follows:
 - PV
 - % range/current
 - Process vars/crnt
 - Process variables
2. After selecting options click **Apply**.
3. After carefully reading the warning provided, select **yes**.

2.14 Multidrop communication

Multidropping transmitters refers to the connection of several transmitters to a single communications transmission line. Communication between the host and the transmitters takes place digitally with the analog output of the transmitters deactivated. With smart communications protocol, up to fifteen transmitters can be connected on a single twisted pair of wires, or over leased phone lines.

Multidrop installation requires consideration of the update rate necessary from each transmitter, the combination of transmitter models, and the length of the transmission line. Communication with transmitters can be accomplished with HART modems and a host implementing HART protocol. Each transmitter is identified by a unique address (1–15) and responds to the commands defined in the HART protocol. Field Communicators and AMS Device Manager can test, configure, and format a multidropped transmitter the same way as a transmitter in a standard point-to-point installation.

Figure 2-13 shows a typical multidrop network. This figure is not intended as an installation diagram.

Note

A transmitter in multidrop mode has the analog output fixed at 4 mA. If an LCD display is installed to a transmitter in multidrop mode, it will alternate the display between “current fixed” and the specified LCD display output(s).

Figure 2-13. Typical Multidrop Network

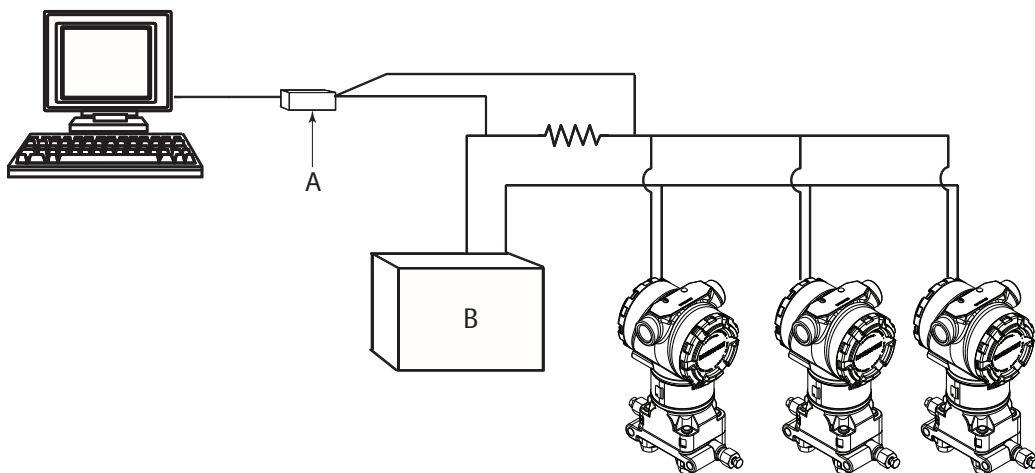

The Rosemount 3051 is set to address zero (0) at the factory, which allows operation in the standard point-to-point manner with a 4–20 mA output signal. To activate multidrop communication, the transmitter address must be changed to a number from one to 15. This change deactivates the 4–20 mA analog output, sending it to 4 mA. It also disables the failure mode alarm signal, which is controlled by the upscale/downscale switch position. Failure signals in multidropped transmitters are communicated through HART messages.

2.15 Changing a transmitter address

To activate multidrop communication, the transmitter poll address must be assigned a number from one to 15, and each transmitter in a multidropped loop must have a unique poll address.

Field Communicator

Traditional 4–20 mA Fast Keys	1, 4, 3, 3, 1
Traditional 1–5 Vdc Fast Keys	1, 4, 3, 3, 1
Device Dashboard Fast Keys	1, 2

AMS Device Manager

Right click on the device and select **Configuration Properties** from the menu.

1. In the *HART* tab, in the *ID* box, enter poll address located in the *Poll addr* box, select **Apply**.
2. After carefully reading the warning provided, select **yes**.

2.15.1 Communicating with a multidropped transmitter

Field Communicator

Traditional 4–20 mA Fast Keys	1, 4, 3, 3, 2
Traditional 1–5 Vdc Fast Keys	1, 4, 3, 3, 2
Device Dashboard Fast Keys	1, 2

To communicate with a multidropped transmitter, configure the Field Communicator to poll for a non-zero address.

1. From the *HOME* screen, enter the Fast Key sequence “Communicating with a Multidropped Transmitter.”
2. On the polling menu, scroll down and select **Digital Poll**. In this mode, the Field Communicator automatically polls for devices at addresses 0–15 upon start up.

AMS Device Manager

Click on the HART modem icon and select **Scan All Devices**.

2.15.2 Polling a multidropped transmitter

Polling a multidropped loop determines the model, address, and number of transmitters on the given loop.

Field Communicator

Traditional 4–20 mA Fast Keys	Left arrow, 4, 1
Traditional 1–5 Vdc Fast Keys	Left arrow, 4, 1
Device Dashboard Fast Keys	1, 2

AMS device manager

Click on the HART modem icon and select **Scan All Devices**.

Section 3 Installation

Overview	page 31
Safety messages	page 31
General considerations	page 32
Mechanical considerations	page 32
Draft range considerations	page 33
Environmental considerations	page 33
HART installation flowchart	page 34
Installation procedures	page 35
Electrical considerations	page 46
Hazardous locations certifications	page 51
Rosemount 305, 306, and 304 Manifolds	page 51
Valve Components	page 58

3.1 Overview

The information in this section covers installation considerations for the Rosemount™ 3051 Pressure Transmitter with HART® protocols. A Quick Start Guide for HART protocol is shipped with every transmitter to describe basic pipe-fitting and wiring procedures for initial installation. Dimensional drawings for each transmitter variation and mounting configuration are included on [page 38](#).

3.2 Safety messages

Procedures and instructions in this section may require special precautions to ensure the safety of the personnel performing the operation. Information that raises potential safety issues is indicated by a warning symbol (⚠). Refer to the following safety messages before performing an operation preceded by this symbol.

⚠ WARNING

Explosions could result in death or serious injury.

Installation of this transmitter in an explosive environment must be in accordance with the appropriate local, national, and international standards, codes, and practices. Review the approvals section of this manual for any restrictions associated with a safe installation.

- Before connecting a Field Communicator in an explosive atmosphere, ensure the instruments in the loop are installed in accordance with intrinsically safe or non-incendive field wiring practices.
- In an Explosion-Proof/Flameproof installation, do not remove the transmitter covers when power is applied to the unit.

Process leaks may cause harm or result in death.

- Install and tighten process connectors before applying pressure.

⚠ WARNING

Electrical shock can result in death or serious injury.

- Avoid contact with the leads and terminals. High voltage that may be present on leads can cause electrical shock.

Replacement equipment or spare parts not approved by Emerson™ for use as spare parts could reduce the pressure retaining capabilities of the transmitter and may render the instrument dangerous.

- Use only bolts supplied or sold by Emerson as spare parts.
- Refer to “Spare parts” on page 136 for a complete list of spare parts.

Improper assembly of manifolds to traditional flange can damage sensor module.

- For safe assembly of manifold to traditional flange, bolts must break back plane of flange web (i.e., bolt hole) but must not contact sensor module housing.

3.3 General considerations

Measurement accuracy depends upon proper installation of the transmitter and impulse piping. Mount the transmitter close to the process and use a minimum of piping to achieve best accuracy. Keep in mind the need for easy access, personnel safety, practical field calibration, and a suitable transmitter environment. Install the transmitter to minimize vibration, shock, and temperature fluctuation.

Important

Install the enclosed pipe plug (found in the box) in unused conduit opening with a minimum of five threads engaged to comply with explosion-proof requirements.

Refer to Material Selection Consideration for Pressure Transmitters [Technical Note](#) for material compatibility considerations.

3.4 Mechanical considerations

Note

For steam service or for applications with process temperatures greater than the limits of the transmitter, do not blow down impulse piping through the transmitter. Flush lines with the blocking valves closed and refill lines with water before resuming measurement.

Note

When the transmitter is mounted on its side, position the coplanar flange to ensure proper venting or draining. Mount the flange as shown in [Figure 3-8 on page 41](#), keeping drain/vent connections on the bottom for gas service and on the top for liquid service.

3.5 Draft range considerations

Installation

For the Rosemount 3051CD0 Draft Range Pressure Transmitter, it is best to mount the transmitter with the isolators parallel to the ground. Installing the transmitter in this way reduces oil head effect and provides for optimal temperature performance.

Be sure the transmitter is securely mounted. Tilting of the transmitter may cause a zero shift in the transmitter output.

Reducing process noise

There are two recommended methods of reducing process noise: output damping and, in gage applications, reference side filtering.

Output damping

The output damping for the Rosemount 3051CD0 is factory set to 3.2 seconds as a default. If the transmitter output is still noisy, increase the damping time. If faster response is needed, decrease the damping time. Damping adjustment information is available on [page 20](#).

Reference side filtering

In gage applications it is important to minimize fluctuations in atmospheric pressure to which the low side isolator is exposed.

One method of reducing fluctuations in atmospheric pressure is to attach a length of tubing to the reference side of the transmitter to act as a pressure buffer.

Another method is to plumb the reference side to a chamber that has a small vent to atmosphere. If multiple draft transmitters are being used in an application, the reference side of each device can be plumbed to a chamber to achieve a common gage reference.

3.6 Environmental considerations

Best practice is to mount the transmitter in an environment that has minimal ambient temperature change. The transmitter electronics temperature operating limits are -40 to 185 °F (-40 to 85 °C). Refer to [Figure 2-12 on page 21](#) that lists the sensing element operating limits. Mount the transmitter so that it is not susceptible to vibration and mechanical shock and does not have external contact with corrosive materials.

3.7 HART installation flowchart

Figure 3-1. HART Flowchart

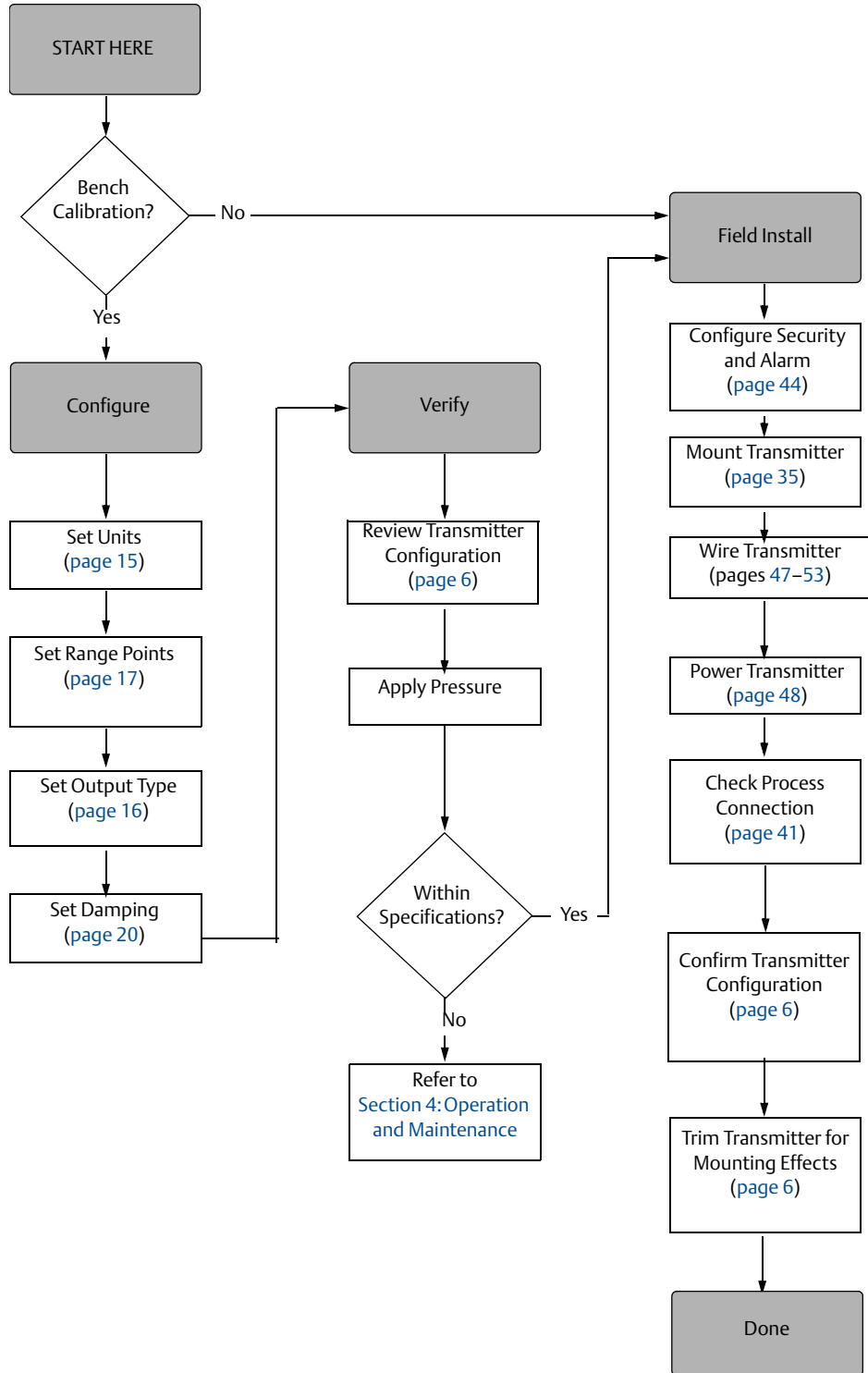

3.8 Installation procedures

3.8.1 Mount the transmitter

For dimensional drawing information refer to [Appendix A: Specifications and Reference Data](#) on page 89.

Process flange orientation

Mount the process flanges with sufficient clearance for process connections. For safety reasons, place the drain/vent valves so the process fluid is directed away from possible human contact when the vents are used. In addition, consider the need for a testing or calibration input.

Note

Most transmitters are calibrated in the horizontal position. Mounting the transmitter in any other position will shift the zero point to the equivalent amount of liquid head pressure caused by the varied mounting position. To reset zero point, refer to [“Sensor trim”](#) on page 71.

Housing rotation

See [“Housing rotation”](#) on page 43.

Terminal side of electronics housing

Mount the transmitter so the terminal side is accessible. Clearance of 0.75-in. (19 mm) is required for cover removal. Use a conduit plug in the unused conduit opening.

Circuit side of electronics housing

Provide 0.75-in. (19 mm) of clearance for units with out an LCD display. Three inches of clearance is required for cover removal if a meter is installed.

Cover installation

Always ensure a proper seal by installing the electronics housing cover(s) so that metal contacts metal. Use Rosemount O-rings.

Environmental seal for housing

Thread sealing (PTFE) tape or paste on male threads of conduit is required to provide a water/dust tight conduit seal and meets requirements of NEMA[®] Type 4X, IP66, and IP68. Consult factory if other Ingress Protection ratings are required.

For M20 threads, install conduit plugs to full thread engagement or until mechanical resistance is met.

Mounting brackets

Rosemount 3051 Transmitters may be panel-mounted or pipe-mounted through an optional mounting bracket. Refer to [Table 3-1](#) for the complete offering and see [Figure 3-2](#) through [Figure 3-5](#) on pages 36 and 37 for dimensions and mounting configurations.

Table 3-1. Rosemount 3051 Mounting Brackets

Option code	Process connections			Mounting			Materials			
	Coplanar	In-line	Traditional	Pipe mount	Panel mount	Flat panel mount	CS bracket	SST bracket	CS bolts	SST bolts
B4	X	X	N/A	X	X	X	N/A	X	N/A	X
B1	N/A	N/A	X	X	N/A	N/A	X	N/A	X	N/A
B2	N/A	N/A	X	N/A	X	N/A	X	N/A	X	N/A
B3	N/A	N/A <td X	N/A	N/A	X	X	N/A	X	N/A	
B7	N/A	N/A	X	X	N/A	N/A	X	N/A	N/A	X
B8	N/A	N/A	X	N/A	X	N/A	X	N/A	N/A	X
B9	N/A	N/A	X	N/A	N/A	X	X	N/A	N/A	X
BA	N/A	N/A	X	X	N/A	N/A	N/A	X	N/A	X
BC	N/A	N/A	X	N/A	N/A	X	N/A	X	N/A	X

Figure 3-2. Mounting Bracket Option Code B4

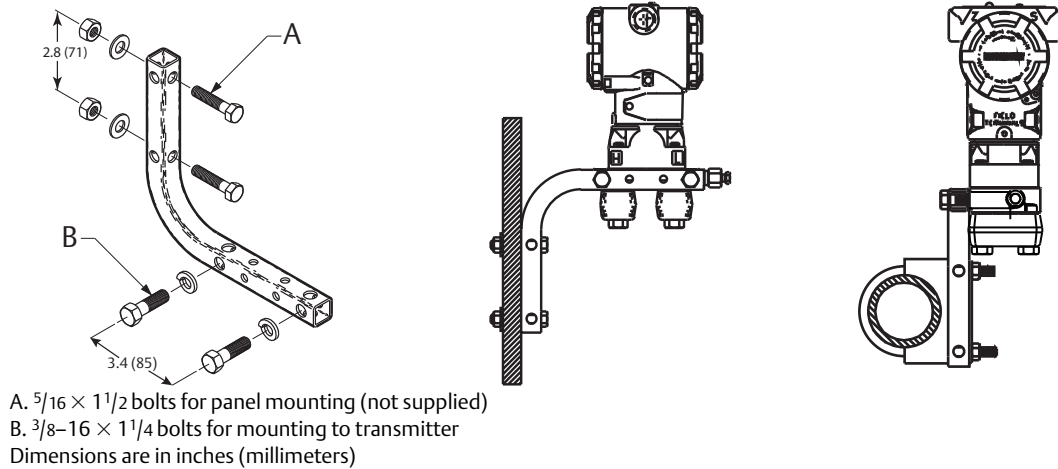

Figure 3-3. Mounting Bracket Option Codes B1, B7, and BA

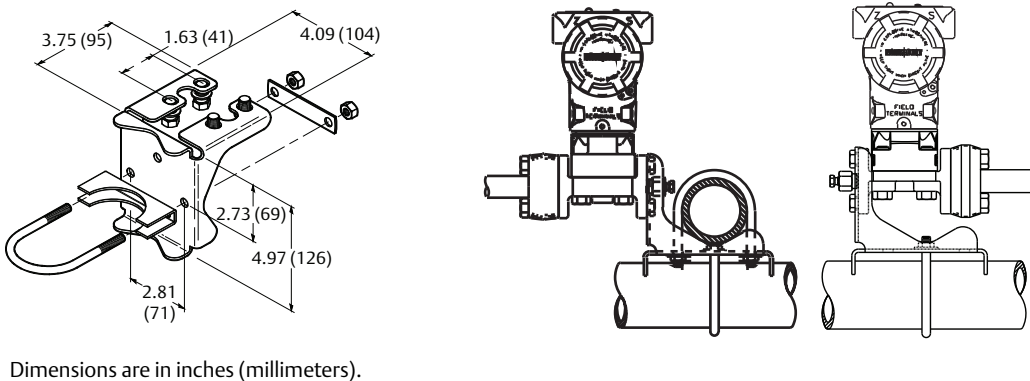
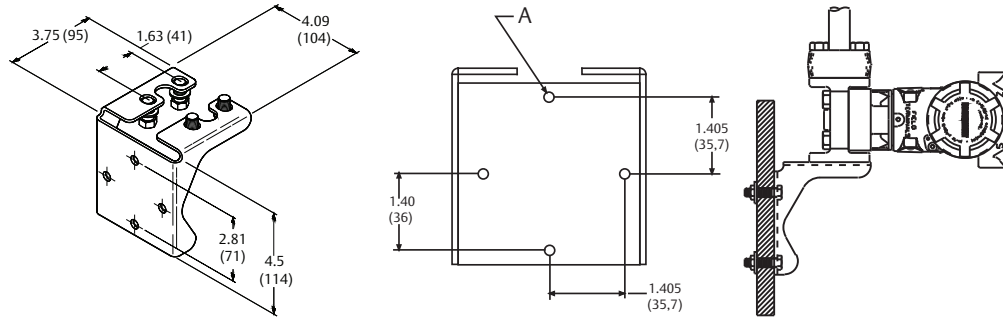
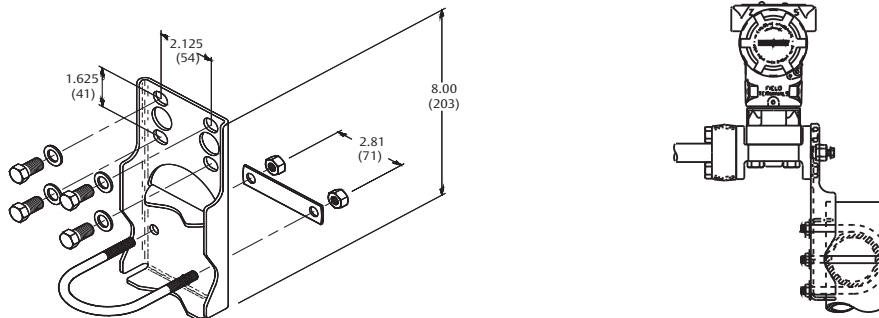

Figure 3-4. Panel Mounting Bracket Option Codes B2 and B8



A. Mounting holes 0.375 diameter (10)
Dimensions are in inches (millimeters).

Figure 3-5. Flat Mounting Bracket Option Codes B3 and BC



Dimensions are in inches (millimeters).

Flange bolts

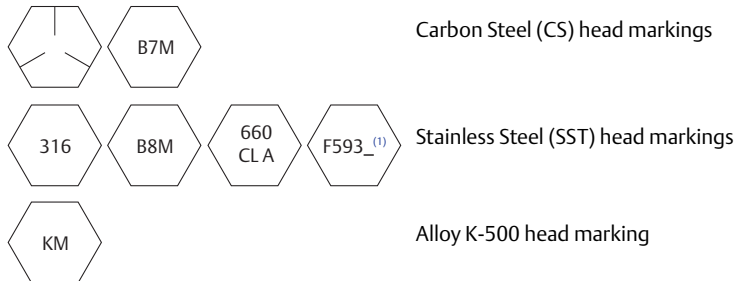

1. The last digit in the F593_ head marking may be any letter between A and M.

The Rosemount 3051 can be shipped with a coplanar flange or a traditional flange installed with four 1.75-in. flange bolts. Mounting bolts and bolting configurations for the coplanar and traditional flanges can be found on [page 39](#). Stainless steel bolts supplied by Emerson Process Management are coated with a lubricant to ease installation. Carbon steel bolts do not require lubrication. No additional lubricant should be applied when installing either type of bolt. Bolts supplied by Emerson are identified by their head markings:

Bolt installation

⚠ Only use bolts supplied with the Rosemount 3051 or sold by Emerson as spare parts for the transmitter. Use the following bolt installation procedure:

1. Finger-tighten the bolts.
2. Torque the bolts to the initial torque value using a crossing pattern (see [Table 3-2](#) for torque values).
3. Torque the bolts to the final torque value using the same crossing pattern.

Table 3-2. Bolt Installation Torque Values

Bolt material	Initial torque value	Final torque value
CS-ASTM-A445 Standard	300 in-lb (34 N-m)	650 in-lb (73 N-m)
316 SST—Option L4	150 in-lb (17 N-m)	300 in-lb (34 N-m)
ASTM-A-19 B7M—Option L5	300 in-lb (34 N-m)	650 in-lb (73 N-m)
Alloy 400—Option L6	300 in-lb (34 N-m)	650 in-lb (73 N-m)

Figure 3-6. Traditional Flange Bolt Configurations

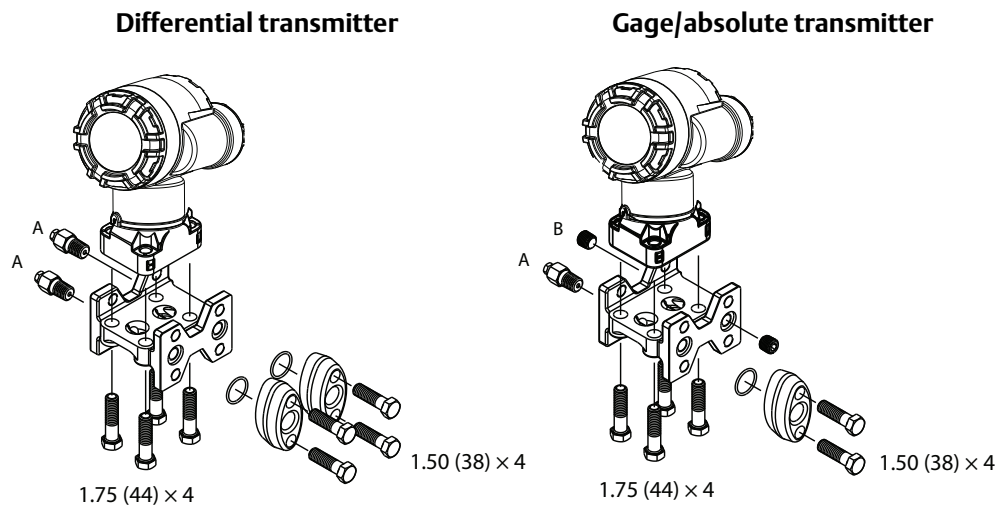

A. Drain/vent
B. Plug
Dimensions are in inches (millimeters).

⚠ See “Safety messages” on page 31 for complete warning information.

Figure 3-7. Mounting Bolts and Bolt Configurations for Coplanar Flange

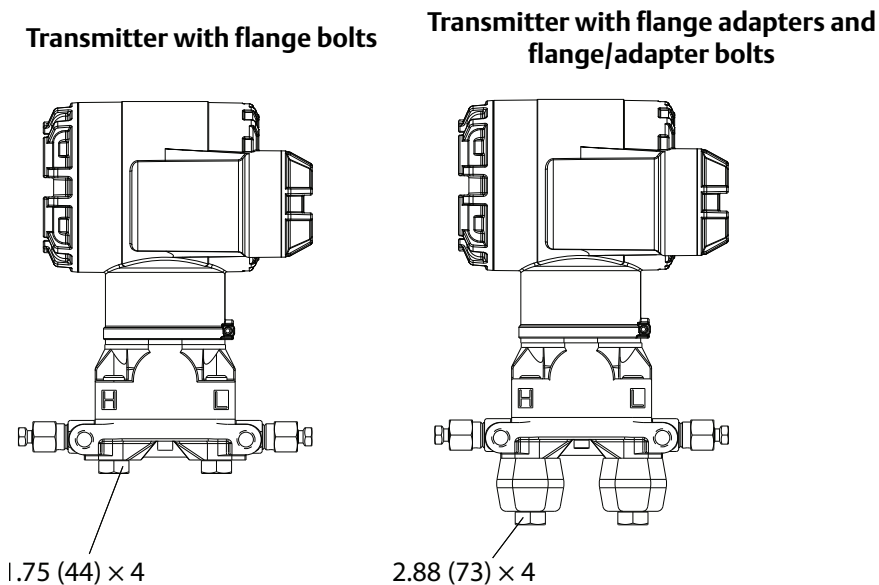

Dimensions are in inches (millimeters).

Description	Qty	Size in. (mm)
Differential pressure		
Flange bolts	4	1.75 (44)
Flange/adapter bolts	4	2.88 (73)
Gage/absolute pressure ⁽¹⁾		
Flange bolts	4	1.75 (44)
Flange/adapter bolts	2	2.88 (73)

1. Rosemount 3051T transmitters are direct mount and do not require bolts for process connection.

3.8.2 Impulse piping

The piping between the process and the transmitter must accurately transfer the pressure to obtain accurate measurements. There are five possible sources of error: pressure transfer, leaks, friction loss (particularly if purging is used), trapped gas in a liquid line, liquid in a gas line, and density variations between the legs.

The best location for the transmitter in relation to the process pipe is dependent on the process. Use the following guidelines to determine transmitter location and placement of impulse piping:

- Keep impulse piping as short as possible.
- For liquid service, slope the impulse piping at least 1 in./ft (8 cm/m) upward from the transmitter toward the process connection.
- For gas service, slope the impulse piping at least 1 in./ft (8 cm/m) downward from the transmitter toward the process connection.

- Avoid high points in liquid lines and low points in gas lines.
- Make sure both impulse legs are the same temperature.
- Use impulse piping large enough to avoid friction effects and blockage.
- Vent all gas from liquid piping legs.
- When using a sealing fluid, fill both piping legs to the same level.
- When purging, make the purge connection close to the process taps and purge through equal lengths of the same size pipe. Avoid purging through the transmitter.
- Keep corrosive or hot (above 250 °F [121 °C]) process material out of direct contact with the sensor module and flanges.
- Prevent sediment deposits in the impulse piping.
- Maintain equal leg of head pressure on both legs of the impulse piping.
- Avoid conditions that might allow process fluid to freeze within the process flange.

Mounting requirements

Impulse piping configurations depend on specific measurement conditions. Refer to [Figure 3-8](#) for examples of the following mounting configurations:

Liquid flow measurement

- Place taps to the side of the line to prevent sediment deposits on the transmitter's process isolators.
- Mount the transmitter beside or below the taps so gases can vent into the process line.
- Mount drain/vent valve upward to allow gases to vent.

Gas flow measurement

- Place taps in the top or side of the line.
- Mount the transmitter beside or above the taps so liquid will drain into the process line.

Steam flow measurement

- Place taps to the side of the line.
- Mount the transmitter below the taps to ensure that the impulse piping will stay filled with condensate.
- In steam service above 250 °F (121 °C), fill impulse lines with water to prevent steam from contacting the transmitter directly and to ensure accurate measurement start-up.

Note

For steam or other elevated temperature services, it is important that temperatures at the process connection do not exceed the transmitter's process temperature limits.

Figure 3-8. Installation Examples

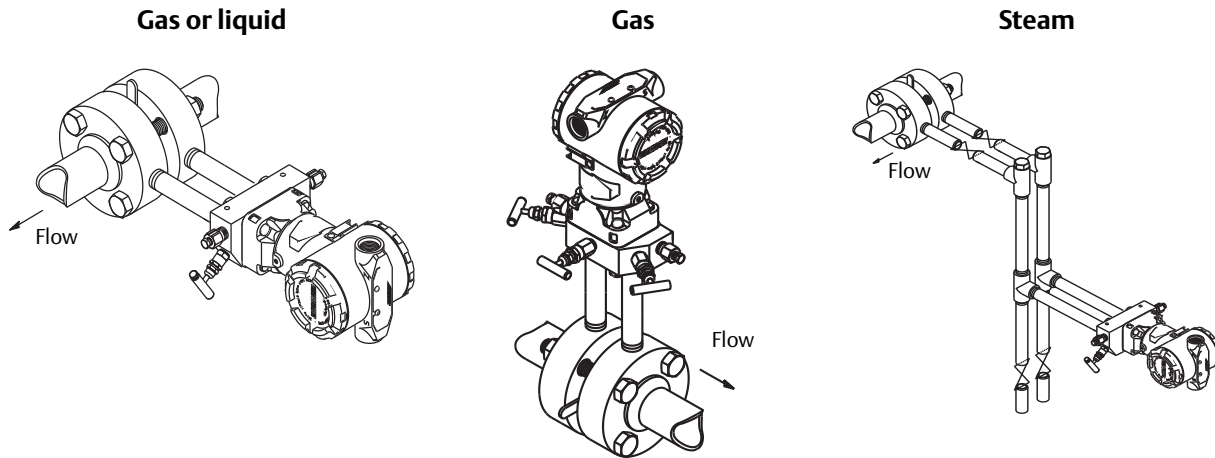

3.8.3 Process connections

Coplanar or traditional process connection

- ⚠ Install and tighten all four flange bolts before applying pressure, or process leakage will result. When properly installed, the flange bolts will protrude through the top of the sensor module housing. Do not attempt to loosen or remove the flange bolts while the transmitter is in service.

Flange adapters

- ⚠ Rosemount 3051DP and GP process connections on the transmitter flanges are 1/4-18 NPT. Flange adapters are available with standard 1/2-14 NPT Class 2 connections. The flange adapters allow users to disconnect from the process by removing the flange adapter bolts. Use plant-approved lubricant or sealant when making the process connections. Refer to “[Dimensional drawings](#)” on page 101 for the distance between pressure connections. This distance may be varied $\pm 1/8$ -in. (3.2 mm) by rotating one or both of the flange adapters.

To install adapters to a coplanar flange, perform the following procedure:

1. Remove the flange bolts.
2. Leaving the flange in place, move the adapters into position with the O-ring installed.
3. Clamp the adapters and the coplanar flange to the transmitter sensor module using the larger of the bolts supplied.
4. Tighten the bolts. Refer to “[Flange bolts](#)” on page 37 for torque specifications.

Whenever you remove flanges or adapters, visually inspect the PTFE O-rings. Replace with O-ring designed for Rosemount transmitter if there are any signs of damage, such as nicks or cuts. Undamaged O-rings may be reused. If you replace the O-rings, retorque the flange bolts after installation to compensate for cold flow. Refer to the process sensor body reassembly procedure in [Section 5: Troubleshooting](#).

O-rings

The two styles of Rosemount flange adapters (Rosemount 1151 and Rosemount 3051S/3051/2051/3095) each require a unique O-ring. Use only the O-ring designed for the corresponding flange adaptor.

⚠ WARNING

Failure to install proper flange adapter O-rings may cause process leaks, which can result in death or serious injury. The two flange adapters are distinguished by unique O-ring grooves. Only use the O-ring that is designed for its specific flange adapter, as shown below.

ROSEMOUNT 3051S/3051/2051/3001/3095/2024

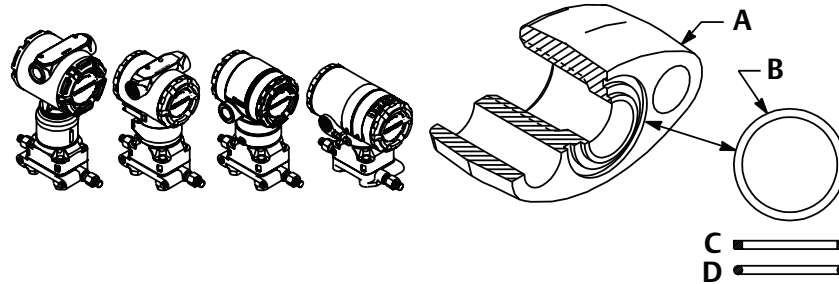

ROSEMOUNT 1151

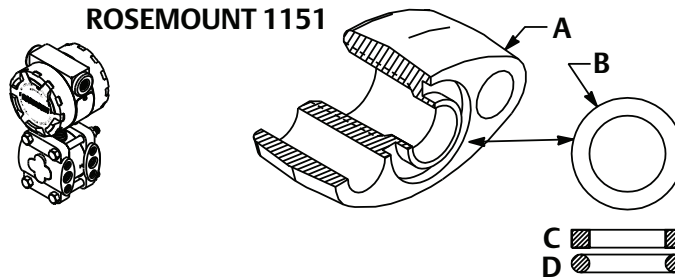

- A. Flange Adapter
- B. O-ring
- C. PTFE
- D. Elastomer

When compressed, PTFE O-rings tend to “cold flow,” which aids in their sealing capabilities.

Note

PTFE O-rings should be replaced if the flange adapter is removed.

3.8.4 Inline process connection

Inline gage transmitter orientation

The low side pressure port on the inline gage transmitter is located in the neck of the transmitter, behind the housing. The vent path is 360 degrees around the transmitter between the housing and sensor (See Figure 3-9).

Keep the vent path free of any obstruction, such as paint, dust, and lubrication by mounting the transmitter so that the process can drain away.

Figure 3-9. In-Line Gage Low Side Pressure Port

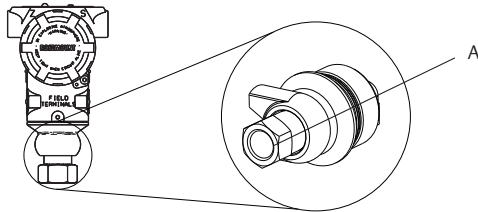

A. Low side pressure port (atmospheric reference)

▲ WARNING

Do not apply torque directly to the sensor module. Rotation between the sensor module and the process connection can damage the electronics. To avoid damage, apply torque only to the hex-shaped process connection.

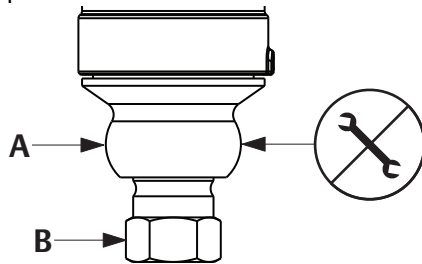

A. Sensor module
B. Process connection

3.8.5 Housing rotation

The electronics housing can be rotated up to 180 degrees in either direction to improve field access, or to better view the optional LCD display. To rotate the housing, perform the following procedure:

1. Loosen the housing rotation set screw using a $5/64$ -in. hex wrench.
2. Turn the housing left or right up to 180° from its original position. Over rotating will damage the transmitter.
3. Retighten the housing rotation set screw.

Figure 3-10. Housing Rotation

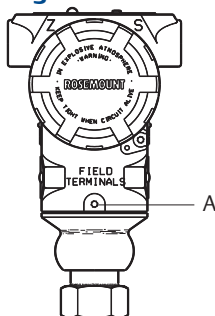

A. Housing rotation set screw ($5/64$ -in.)

3.8.6 LCD display

Transmitters ordered with the LCD option are shipped with the display installed. Installing the display on an existing Rosemount 3051 Transmitter requires a small instrument screwdriver.

Figure 3-11. LCD Display

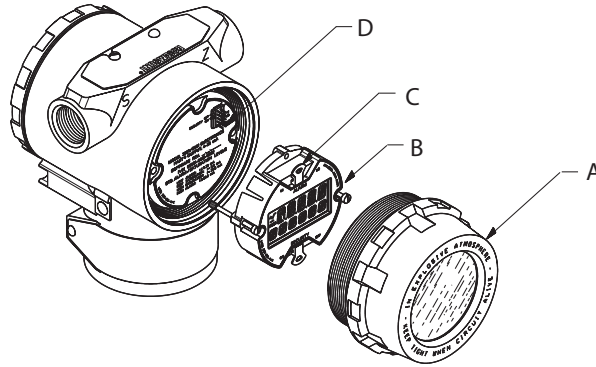

- A. Extended cover
- B. LCD display
- C. Jumpers (top and bottom)
- D. Interconnecting pins

3.8.7 Configure security and alarm

Security (write protect)

There are three security methods with the Rosemount 3051 Transmitter:

1. Security jumper: prevents all writes to transmitter configuration.
2. Local keys (local zero and span) software lock out: prevents changes to transmitter range points via local zero and span adjustment keys. With local keys security enabled, changes to configuration are possible via HART.
3. Physical removal of local keys (local zero and span) magnetic buttons: removes ability to use local keys to make transmitter range point adjustments. With local keys security enabled, changes to configuration are possible via HART.

You can prevent changes to the transmitter configuration data with the write protection jumper. Security is controlled by the security (write protect) jumper located on the electronics board or LCD display. Position the jumper on the transmitter circuit board in the “ON” position to prevent accidental or deliberate change of configuration data.

If the transmitter write protection jumper is in the “ON” position, the transmitter will not accept any “writes” to its memory. Configuration changes, such as digital trim and reranging, cannot take place when the transmitter security is on.

Note

If the security jumper is not installed, the transmitter will continue to operate in the security OFF configuration.

Configuring transmitter security and alarm jumper procedure

To reposition the jumpers, follow the procedure described below.

1. Do not remove the transmitter covers in explosive atmospheres when the circuit is live. If the transmitter is live, set the loop to manual and remove power.
- ⚠ 2. Remove the housing cover opposite the field terminal side. Do not remove the transmitter covers in explosive atmospheres when the circuit is live.
3. Reposition the jumpers as desired.
 - Figure 3-12 shows the jumper positions for the 4-20 mA HART Transmitter.
 - Figure 3-13 shows the jumper positions for the 1-5 HART Vdc Low Power Transmitter.
- ⚠ 4. Reattach the transmitter cover. Always ensure a proper seal by installing the electronics housing covers so that metal contacts metal to meet explosion-proof requirements.

Figure 3-12. 4–20 mA HART Electronics Board

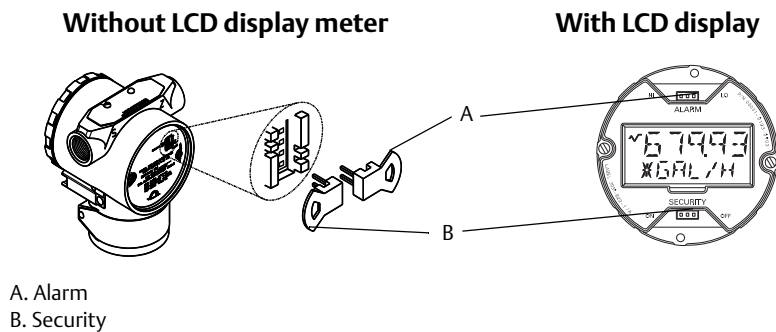
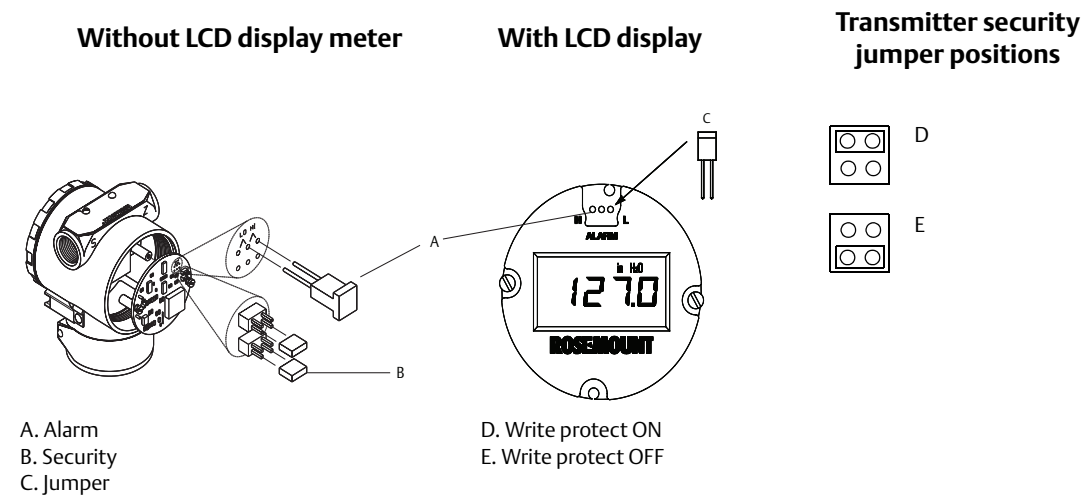

Figure 3-13. 1-5 Vdc HART Low Power Transmitter Electronics Boards



Note

Security jumper not installed = not write protected
Alarm jumper not installed = high alarm

3.9 Electrical considerations

Note

Make sure all electrical installation is in accordance with national and local code requirements.

3.9.1 Conduit installation

⚠ CAUTION

If all connections are not sealed, excess moisture accumulation can damage the transmitter. Make sure to mount the transmitter with the electrical housing positioned downward for drainage. To avoid moisture accumulation in the housing, install wiring with a drip loop, and ensure the bottom of the drip loop is mounted lower than the conduit connections or the transmitter housing.

Recommended conduit connections are shown in [Figure 3-14](#).

Figure 3-14. Conduit Installation Diagrams

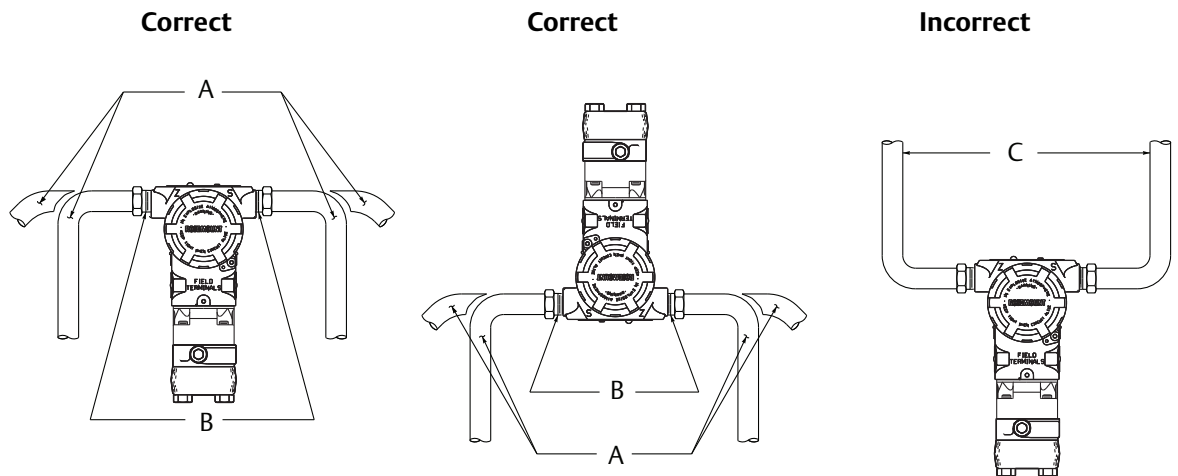

- A. Possible conduit line positions
- B. Sealing compound
- C. Conduit lines

3.9.2 Wiring

⚠ CAUTION

Do not connect the power signal wiring to the test terminals. Voltage may burn out the reverse-polarity protection diode in the test connection.

Note

Use shielded twisted pairs to yield best results. To ensure proper communication, use 24 AWG or larger wire, and do not exceed 5000 ft (1500 m).

Figure 3-15. 4–20 mA HART Wiring

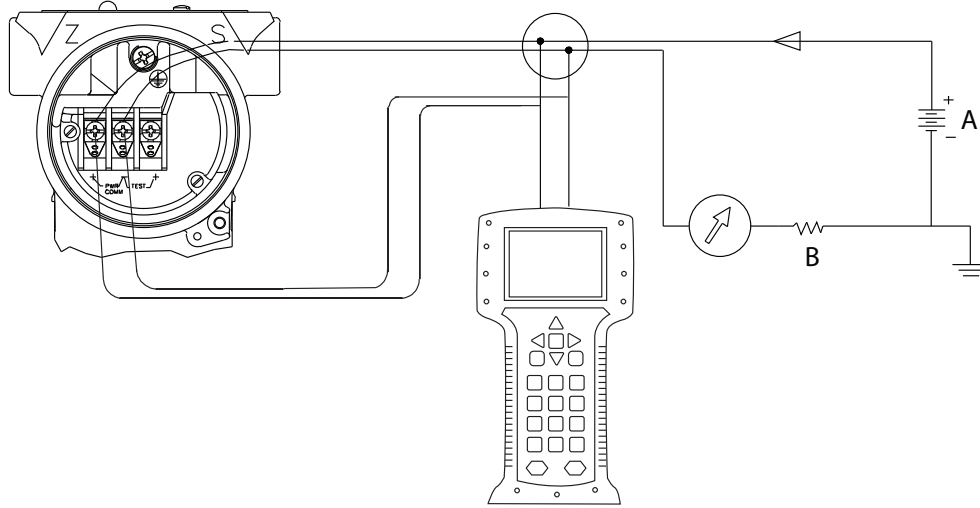

A. Power supply
B. $RL \geq 250\Omega$

Figure 3-16. 1–5 Vdc Low Power Wiring

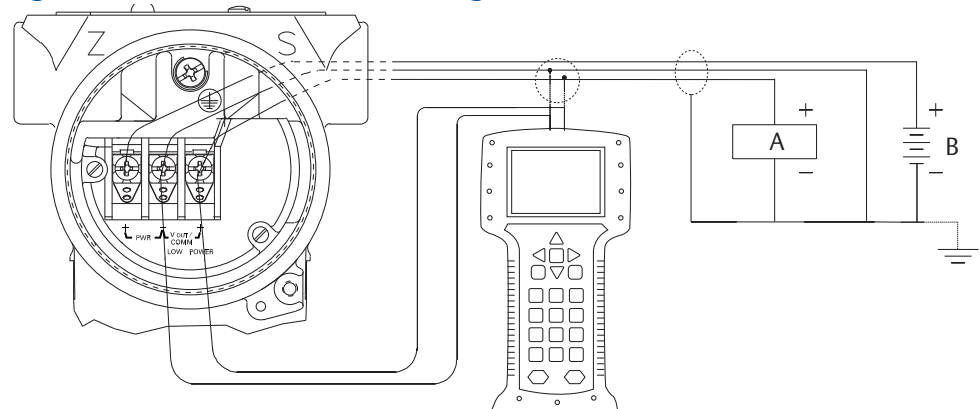

A. Voltmeter
B. Power supply

Perform the following procedure to make wiring connections:

- ⚠ 1. Remove the housing cover on terminal compartment side. Do not remove the cover in explosive atmospheres when the circuit is live. Signal wiring supplies all power to the transmitter.
- ⚠ 2. For 4–20 mA HART output, connect the positive lead to the terminal marked (+) and the negative lead to the terminal marked (pwr/comm-). Do not connect powered signal wiring to the test terminals. Power could damage the test diode.

For 1–5 Vdc HART Low Power output, connect the positive lead to the terminal marked (+ pwr) and the negative lead to the terminal marked (pwr-). Connect signal lead to $V_{out}/comm+$.

⚠ See “Safety messages” on page 31 for complete warning information.

3. Ensure full contact with Terminal Block screw and washer. When using a direct wiring method, wrap wire clockwise to ensure it is in place when tightening the terminal block screw.

Note

The use of a pin or ferrule wire terminal is not recommended as the connection may be more susceptible to loosening over time or under vibration.

4. Plug and seal unused conduit connection on the transmitter housing to avoid moisture accumulation in the terminal side. Install wiring with a drip loop. Arrange the drip loop so the bottom is lower than the conduit connections and the transmitter housing.

Power supply for 4-20 mA HART

Transmitter operates on 10.5 –42.4 Vdc. The dc power supply should provide power with less than two percent ripple.

Note

A minimum loop resistance of 250 ohms is required to communicate with a Field Communicator. If a single power supply is used to power more than one Rosemount 3051 Transmitter, the power supply used, and circuitry common to the transmitters, should not have more than 20 ohms of impedance at 1200 Hz.

Figure 3-17. Load Limitation

Maximum loop resistance = $43.5 * (\text{Power supply voltage} - 10.5)$

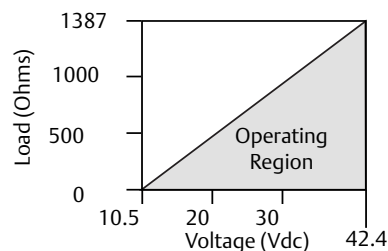

The Field Communicator requires a minimum loop resistance of 250Ω for communication.

The total resistance load is the sum of the resistance of the signal leads and the load resistance of the controller, indicator, and related pieces. Note that the resistance of intrinsic safety barriers, if used, must be included.

Power supply for 1–5 Vdc HART low power

Low power transmitters operate on 6–14 Vdc. The dc power supply should provide power with less than two percent ripple. The V_{out} load should be 100 kΩ or greater.

3.9.3 Transient protection terminal block

The transmitter will withstand electrical transients of the energy level usually encountered in static discharges or induced switching transients. However, high-energy transients, such as those induced in wiring from nearby lightning strikes, can damage the transmitter.

The transient protection terminal block can be ordered as an installed option (option code T1 in the transmitter model number) or as a spare part to retrofit existing Rosemount 3051 Transmitters in the field. See “Spare parts” on page 136 for spare part numbers. The lightning bolt symbol shown in Figure 3-18 and Figure 3-19 identifies the transient protection terminal block.

Figure 3-18. 4–20 mA HART Wiring with Transient Protection

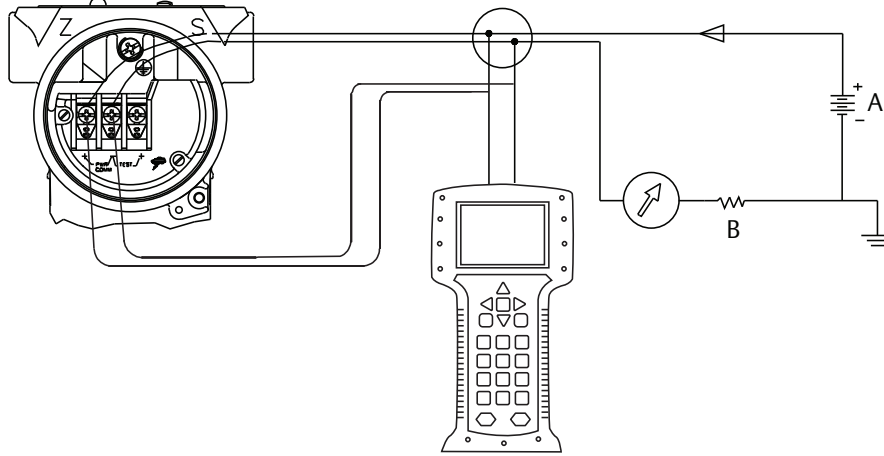

- A. Power supply
- B. $RL \geq 250\Omega$

Figure 3-19. 1–5 Vdc Low Power Wiring with Transient Protection

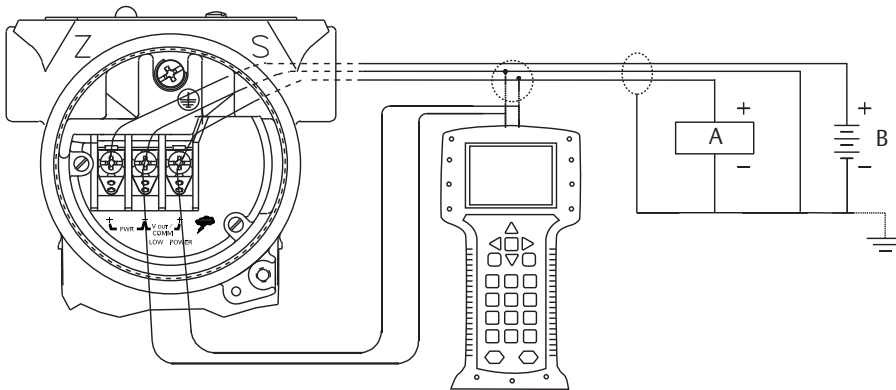

- A. Voltmeter
- B. Power supply

Figure 3-20. Wiring Pair and Ground

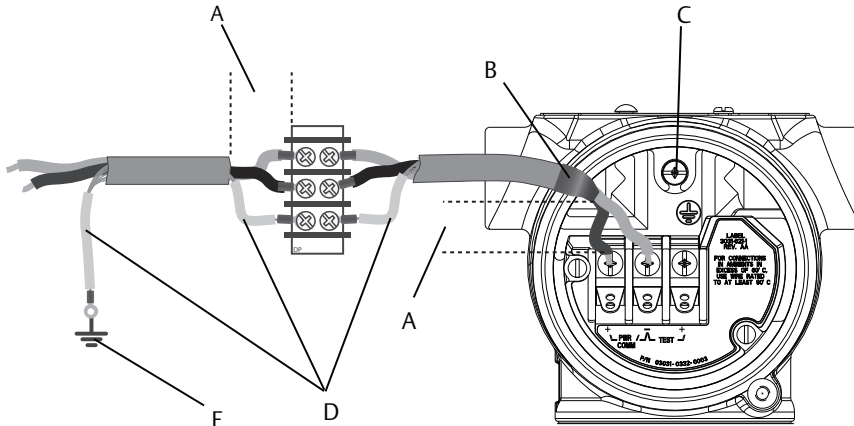

- A. Minimize distance
- B. Trim shield and insulate
- C. Ground for transient protection
- D. Insulate shield
- E. Connect shield back to the power supply ground

Note

The transient protection terminal block does not provide transient protection unless the transmitter case is properly grounded. Use the guidelines to ground the transmitter case. Refer to [page 50](#).

Do not run the transient protection ground wire with signal wiring as the ground wire may carry excessive current if a lightning strike occurs.

3.9.4 Grounding

⚠ Use the following techniques to properly ground the transmitter signal wiring and case:

Signal wiring

Do not run signal wiring in conduit or open trays with power wiring or near heavy electrical equipment. It is important that the instrument cable shield be:

- Trimmed close and insulated from touching the transmitter housing
- Connected to the next shield if cable is routed through a junction box
- Connected to a good earth ground at the power supply end

For 4–20 mA HART output, the signal wiring may be grounded at any one point on the signal loop or may be left ungrounded. The negative terminal of the power supply is a recommended grounding point.

For 1–5 Vdc HART Low Power output, the power wires may be grounded at only one point or left ungrounded. The negative terminal of the power supply is a recommended grounding point.

Transmitter case

Always ground the transmitter case in accordance with national and local electrical codes. The most effective transmitter case grounding method is a direct connection to earth ground with minimal impedance. Methods for grounding the transmitter case include:

- Internal ground connection: The internal ground connection screw is inside the FIELD TERMINALS side of the electronics housing. This screw is identified by a ground symbol (⊕). The ground connection screw is standard on all Rosemount 3051 Transmitters. Refer to [Figure 3-21](#).

Figure 3-21. Internal Ground Screw

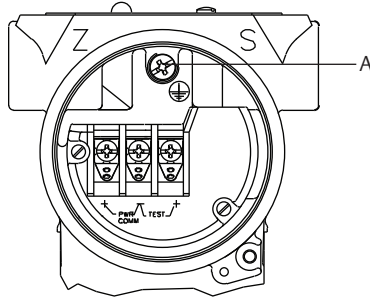

A. Internal ground connection screw

Figure 3-22. External Ground Assembly

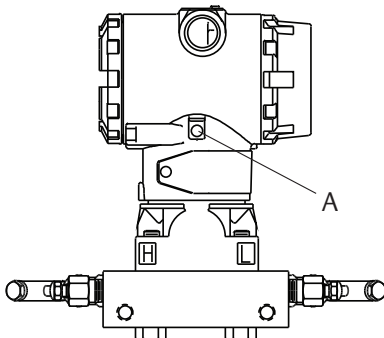

A. External ground assembly

Note

Grounding the transmitter case via threaded conduit connection may not provide sufficient ground continuity.

3.10 Hazardous locations certifications

- ⚠ Individual transmitters are clearly marked with a tag indicating the approvals they carry. Transmitters must be installed in accordance with all applicable codes and standards to maintain these certified ratings. Refer to [Appendix B: Product Certifications](#) for information on these approvals.

3.11 Rosemount 305, 306, and 304 Manifolds

The Rosemount 305 Integral Manifold is available in two designs: traditional and coplanar. The traditional integral manifold can be mounted to most primary elements with mounting adapters in the market today. The Rosemount 306 Integral Manifold is used with the Rosemount 3051T In-Line Transmitters to provide block-and-bleed valve capabilities of up to 10000 psi (690 bar).

Figure 3-23. Manifolds

Rosemount 3051C and 304 Conventional

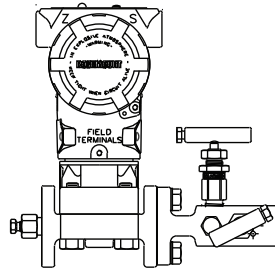

Rosemount 3051C and 305 Integral Coplanar

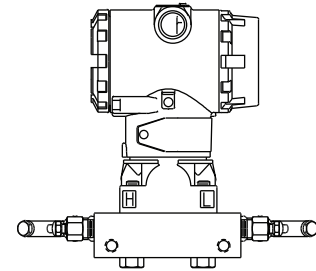

Rosemount 3051C and 305 Integral Traditional

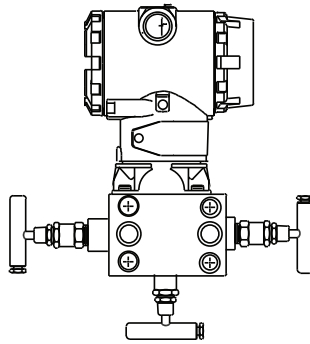

Rosemount 3051T and 306 In-Line

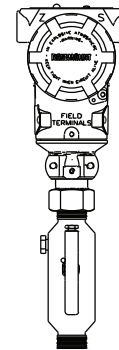

3.11.1

Rosemount 305 Integral Manifold installation procedure

To install a Rosemount 305 Integral Manifold to a Rosemount 3051 Transmitter:

1.  Inspect the PTFE sensor module o-rings. Undamaged O-rings may be reused. If the o-rings are damaged (if they have nicks or cuts, for example), replace with O-rings designed for Rosemount transmitter.

Important

If replacing the O-rings, take care not to scratch or deface the O-ring grooves or the surface of the isolating diaphragm while you remove the damaged O-rings.

2. Install the integral manifold on the sensor module. Use the four 2.25-in. manifold bolts for alignment. Finger tighten the bolts, then tighten the bolts incrementally in a cross pattern to final torque value. See “[Flange bolts](#)” on page 37 for complete bolt installation information and torque values. When fully tightened, the bolts should extend through the top of the sensor module housing.

 See “[Safety messages](#)” on page 31 for complete warning information.

3. If the PTFE sensor module O-rings have been replaced, the flange bolts should be re-tightened after installation to compensate for cold flow of the O-rings.

Note

Always perform a zero trim on the transmitter/manifold assembly after installation to eliminate mounting effects.

3.11.2 Rosemount 306 Integral Manifold installation procedure

The Rosemount 306 Manifold is for use only with a Rosemount 3051T In-Line Transmitter.

- ⚠ Assemble the Rosemount 306 Manifold to the Rosemount 3051T In-Line Transmitter with a thread sealant.

3.11.3 Rosemount 304 Conventional Manifold installation procedure

To install a Rosemount 304 Conventional Manifold to a Rosemount 305T Transmitter:

1. Align the conventional manifold with the transmitter flange. Use the four manifold bolts for alignment.
2. Finger tighten the bolts, then tighten the bolts incrementally in a cross pattern to final torque value. See “[Flange bolts](#)” on page 37 for complete bolt installation information and torque values. When fully tightened, the bolts should extend through the top of the sensor module housing.
3. Leak-check assembly to maximum pressure range of transmitter.

3.11.4 Manifold operation

⚠ WARNING

Improper installation or operation of manifolds may result in process leaks, which may cause death or serious injury.

Always perform a zero trim on the transmitter/manifold assembly after installation to eliminate any shift due to mounting effects. See “[Sensor trim overview](#)” on page 71.

Coplanar transmitters

3- and 5-valve manifolds

Performing zero trim at static line pressure

In normal operation the two isolate (block) valves between the process ports and transmitter will be open and the equalize valve will be closed.

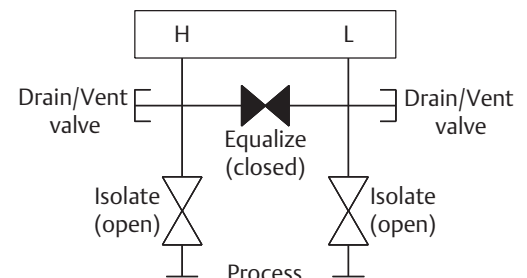

1. To zero trim the transmitter, close the isolate valve on the low side (downstream) side of the transmitter.

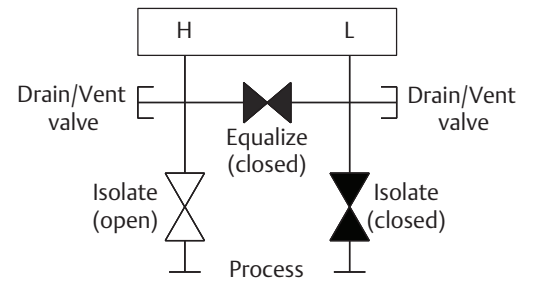

2. Open the equalize valve to equalize the pressure on both sides of the transmitter. The manifold is now in the proper configuration for performing a zero trim on the transmitter.

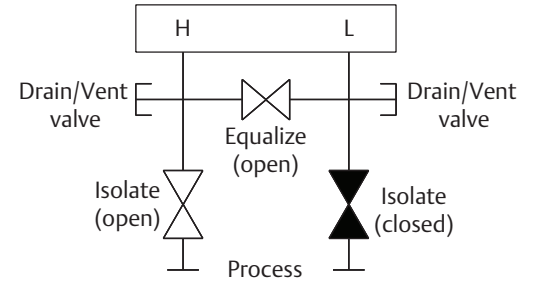

3. After performing a zero trim on the transmitter, close the equalize valve.

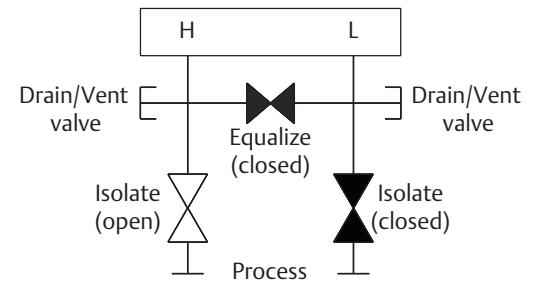

4. Finally, to return the transmitter to service, open the low side isolate valve.

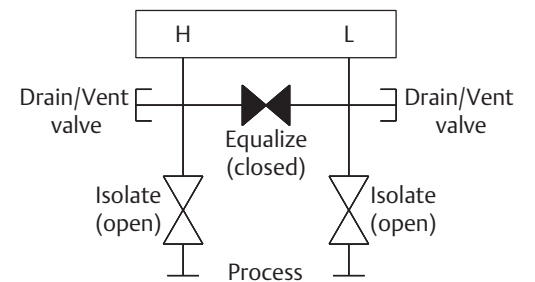

5-valve natural gas manifold

Performing zero trim at static line pressure

5-valve natural gas configurations shown:

In normal operation, the two isolate (block) valves between the process ports and transmitter will be open, and the equalize valves will be closed. Vent valves may be opened or closed.

1. To zero trim the transmitter, first close the isolate valve on the low pressure (downstream) side of the transmitter and the vent valve.

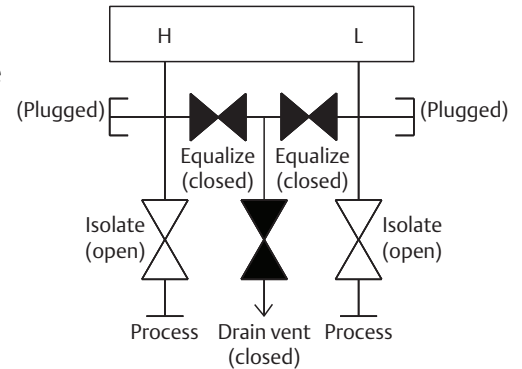

2. Open the equalize valve on the high pressure (upstream) side of the transmitter.

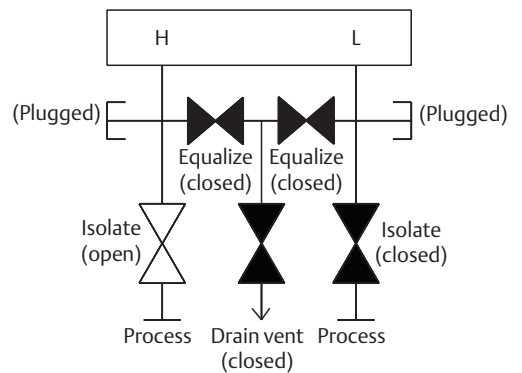

3. Open the equalize valve on the low pressure (downstream) side of the transmitter. The manifold is now in the proper configuration for performing a zero trim on the transmitter.

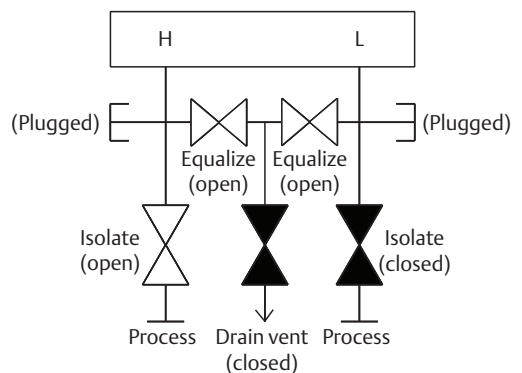
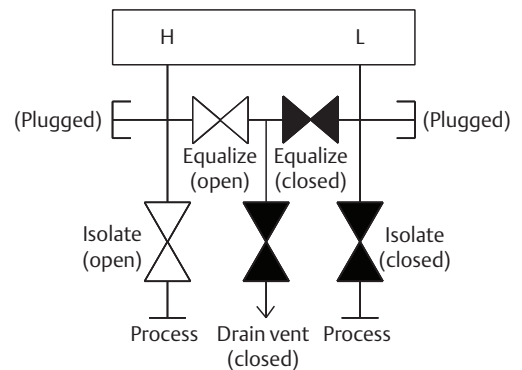

- After performing a zero trim on the transmitter, close the equalize valve on the low pressure (downstream) side of the transmitter.

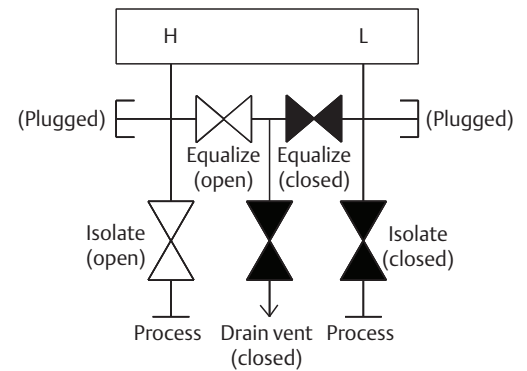

- Close the equalize valve on the high pressure (upstream) side.

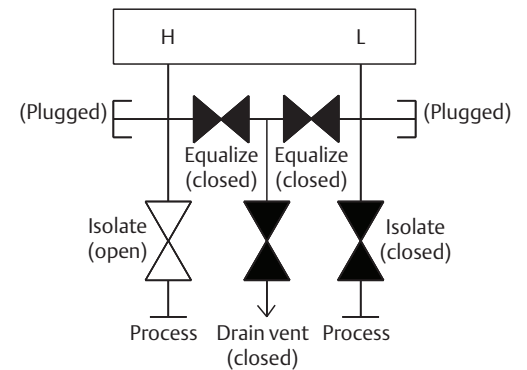

- Finally, to return the transmitter to service, open the low side isolate valve and vent valve. The vent valve can remain open or closed during operation.

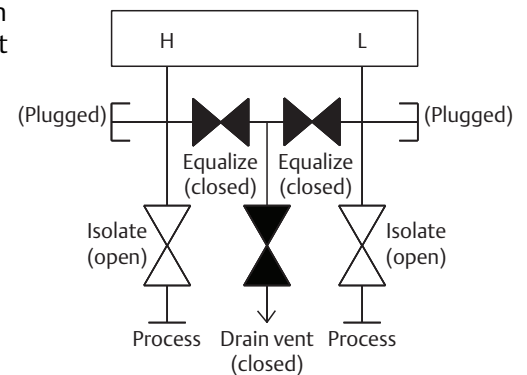

In-line transmitter

2-valve and block and bleed style manifolds

Isolating the transmitter

In normal operation the isolate (block) valve between the process port and transmitter will be open and the test/vent valve will be closed. On a block and bleed style manifold, a single block valve provides transmitter isolation and a bleed screw provides drain/vent capabilities.

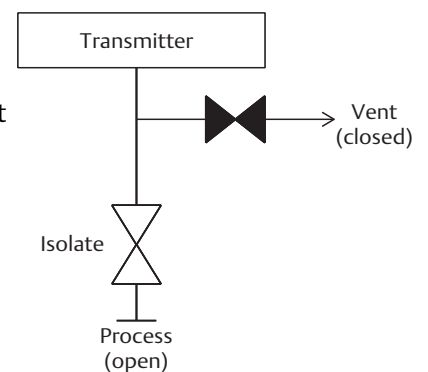

- To isolate the transmitter, close the isolate valve.

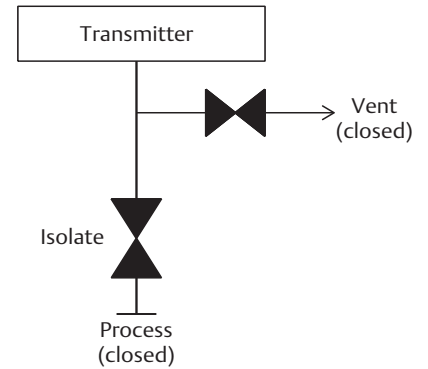

- To bring the transmitter to atmospheric pressure, open the vent valve or bleed screw.

Note

A 1/4-in. male NPT pipe plug may be installed in the test/vent port and will need to be removed with a wrench in order to vent the manifold properly.

⚠ Always use caution when venting directly to atmosphere.

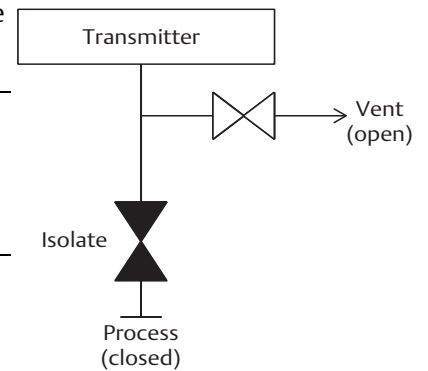

- After venting to atmosphere, perform any required calibration and then close the test/vent valve or replace the bleed screw.

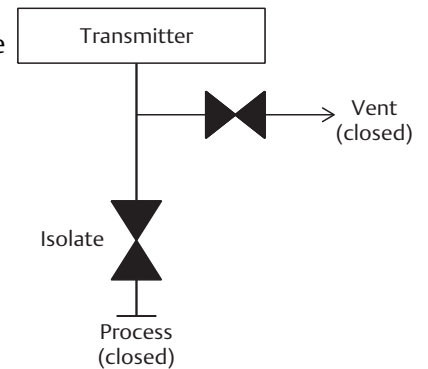

- Open the Isolate (block) valve to return the transmitter to service.

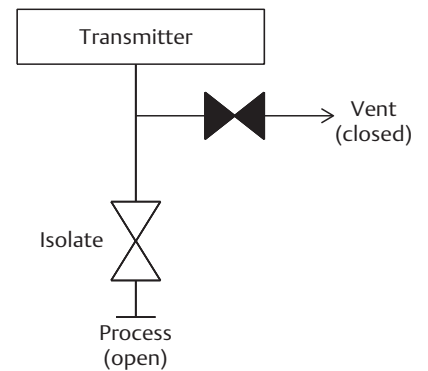

Adjusting valve packing

Over time, the packing material inside a Rosemount manifold may require adjustment in order to continue to provide proper pressure retention. Not all Rosemount manifolds have this adjustment capability. The Rosemount manifold model number will indicate what type of stem seal or packing material has been used.

The following steps are provided as a procedure to adjust valve packing:

1. Remove all pressure from device.
2. Loosen manifold valve jam nut.
3. Tighten manifold valve packing adjuster nut $\frac{1}{4}$ turn.
4. Tighten manifold valve jam nut.
5. Re-apply pressure and check for leaks.

Above steps can be repeated, if necessary. If the above procedure does not result in proper pressure retention, the complete manifold should be replaced.

Figure 3-24. Valve Components

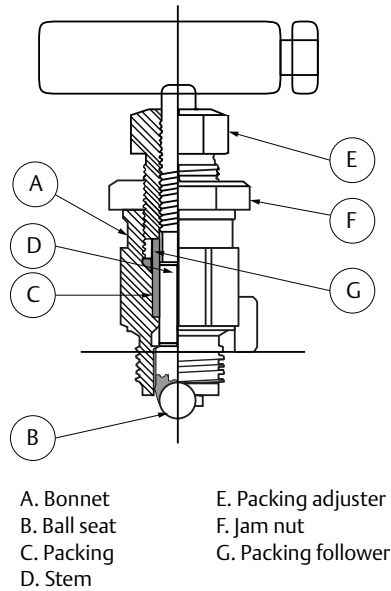

3.12 Liquid level measurement

Differential pressure transmitters used for liquid level applications measure hydrostatic pressure head. Liquid level and specific gravity of a liquid are factors in determining pressure head. This pressure is equal to the liquid height above the tap multiplied by the specific gravity of the liquid. Pressure head is independent of volume or vessel shape.

3.12.1 Open vessels

A pressure transmitter mounted near a tank bottom measures the pressure of the liquid above.

Make a connection to the high pressure side of the transmitter, and vent the low pressure side to the atmosphere. Pressure head equals the liquid's specific gravity multiplied by the liquid height above the tap.

Zero range suppression is required if the transmitter lies below the zero point of the desired level range. [Figure 3-25](#) shows a liquid level measurement example.

3.12.2 Closed vessels

Pressure above a liquid affects the pressure measured at the bottom of a closed vessel. The liquid specific gravity multiplied by the liquid height plus the vessel pressure equals the pressure at the bottom of the vessel.

To measure true level, the vessel pressure must be subtracted from the vessel bottom pressure. To do this, make a pressure tap at the top of the vessel and connect this to the low side of the transmitter. Vessel pressure is then equally applied to both the high and low sides of the transmitter. The resulting differential pressure is proportional to liquid height multiplied by the liquid specific gravity.

Dry leg condition

Low-side transmitter piping will remain empty if gas above the liquid does not condense. This is a dry leg condition. Range determination calculations are the same as those described for bottom-mounted transmitters in open vessels, as shown in [Figure 3-25](#).

Figure 3-25. Liquid Level Measurement Example

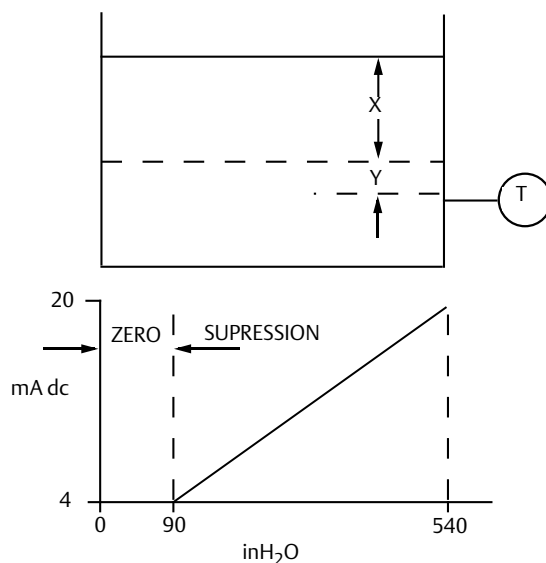

Let X equal the vertical distance between the minimum and maximum measurable levels (500-in.).
 Let Y equal the vertical distance between the transmitter datum line and the minimum measurable level (100-in.).
 Let SG equal the specific gravity of the fluid (0.9).
 Let h equal the maximum head pressure to be measured in inches of water.
 Let e equal head pressure produced by Y expressed in inches of water.
 Let Range equal e to e + h.

$$\begin{aligned} \text{Then } h &= (X)(SG) \\ &= 500 \times 0.9 \\ &= 450 \text{ inH}_2\text{O} \\ e &= (Y)(SG) \\ &= 100 \times 0.9 \\ &= 90 \text{ inH}_2\text{O} \\ \text{Range} &= 90 \text{ to } 540 \text{ inH}_2\text{O} \end{aligned}$$

Wet leg condition

Condensation of the gas above the liquid slowly causes the low side of the transmitter piping to fill with liquid. The pipe is purposely filled with a convenient reference fluid to eliminate this potential error. This is a wet leg condition.

The reference fluid will exert a head pressure on the low side of the transmitter. Zero elevation of the range must then be made. See Figure 3-26.

Figure 3-26. Wet Leg Example

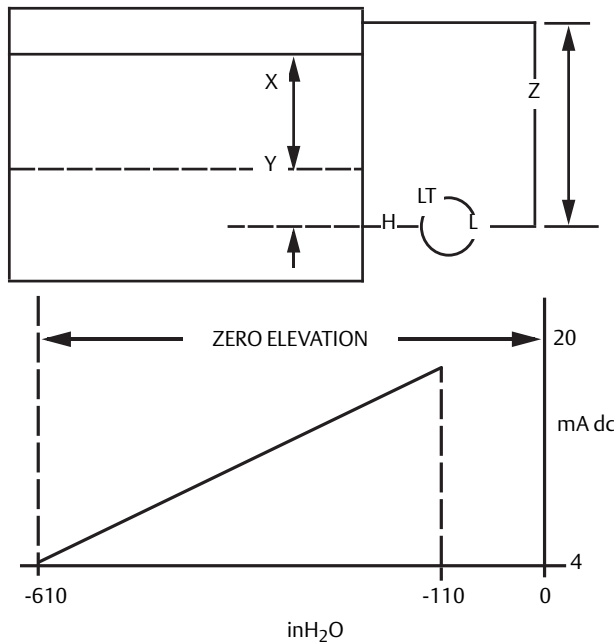

Let X equal the vertical distance between the minimum and maximum measurable levels (500-in.).
 Let Y equal the vertical distance between the transmitter datum line and the minimum measurable level (50-in.).

Let z equal the vertical distance between the top of the liquid in the wet leg and the transmitter datum line (600-in.).

Let $SG1$ equal the specific gravity of the fluid (1.0).

Let $SG2$ equal the specific gravity of the fluid in the wet leg (1.1).

Let h equal the maximum head pressure to be measured in inches of water.

Let e equal the head pressure produced by Y expressed in inches of water.

Let s equal head pressure produced by z expressed in inches of water.

Let Range equal $e - s$ to $h + e - s$.

$$\begin{aligned} \text{Then } h &= (X)(SG1) \\ &= 500 \times 1.0 \\ &= 500 \text{ inH}_2\text{O} \end{aligned}$$

$$\begin{aligned} e &= (Y)(SG1) \\ &= 50 \times 1.0 \\ &= 50 \text{ inH}_2\text{O} \end{aligned}$$

$$\begin{aligned} s &= (z)(SG2) \\ &= 600 \times 1.1 \\ &= 660 \text{ inH}_2\text{O} \end{aligned}$$

$$\begin{aligned} \text{Range} &= e - s \text{ to } h + e - s \\ &= 50 - 660 \text{ to } 500 + 50 - 660 \\ &= -610 \text{ to } -110 \text{ inH}_2\text{O} \end{aligned}$$

Bubbler system in open vessel

A bubbler system that has a top-mounted pressure transmitter can be used in open vessels. This system consists of an air supply, pressure regulator, constant flow meter, pressure transmitter, and a tube that extends down into the vessel.

Bubble air through the tube at a constant flow rate. The pressure required to maintain flow equals the liquid's specific gravity multiplied by the vertical height of the liquid above the tube opening. [Figure 3-27](#) shows a bubbler liquid level measurement example.

Figure 3-27. Bubbler Liquid Level Measurement Example

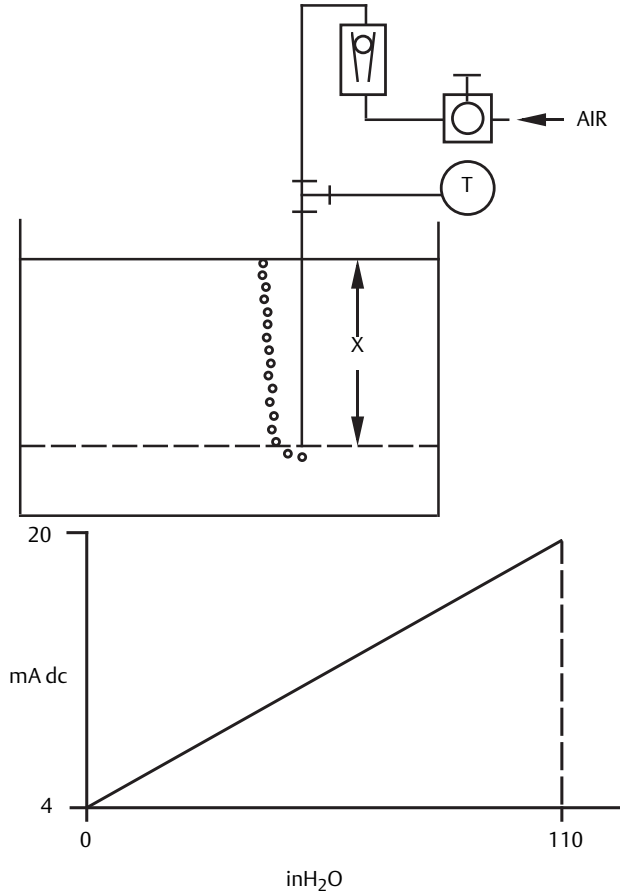

Let X equal the vertical distance between the minimum and maximum measurable levels (100 in.).

Let SG equal the specific gravity of the fluid (1.1).

Let h equal the maximum head pressure to be measured in inches of water.

Let Range equal zero to h.

$$\begin{aligned} \text{Then } h &= (X)(SG) \\ &= 100 \times 1.1 \\ &= 110 \text{ inH}_2\text{O} \end{aligned}$$

Range = 0 to 110 inH₂O

Section 4 Operation and Maintenance

Overview	page 63
Safety messages	page 63
Calibration overview	page 64
Analog output trim	page 68
Sensor trim	page 71

4.1 Overview

This section contains information on calibrating and diagnostics messages on Rosemount™ 3051 Pressure Transmitters.

Field Communicator and AMS Device Manager instructions are given to perform configuration functions. For convenience, Field Communicator Fast Key sequences are labeled “Fast Keys” for each software function below the appropriate headings.

4.2 Safety messages

Procedures and instructions in this section may require special precautions to ensure the safety of the personnel performing the operations. Information that raises potential safety issues is indicated by a warning symbol (⚠). Refer to the following safety messages before performing an operation preceded by this symbol.

⚠ WARNING

Explosions could result in death or serious injury.

Installation of this transmitter in an explosive environment must be in accordance with the appropriate local, national, and international standards, codes, and practices. Review the approvals section of this manual for any restrictions associated with a safe installation.

- Before connecting a Field Communicator in an explosive atmosphere, ensure the instruments in the loop are installed in accordance with intrinsically safe or non-incendive field wiring practices.
- In an Explosionproof/flameproof installation, do not remove the transmitter covers when power is applied to the unit.

Process leaks may cause harm or result in death.

- Install and tighten process connectors before applying pressure.

Electrical shock can result in death or serious injury.

- Avoid contact with the leads and terminals. High voltage that may be present on leads can cause electrical shock.
-

4.3 Calibration overview

Calibration is defined as the process required to optimize transmitter accuracy over a specific range by adjusting the factory sensor characterization curve located in the microprocessor. Possible procedures are:

- Reranging: Setting the lower and upper range points (4 and 20 mA or 1 and 5 Vdc) points at required pressures. Reranging does not change the factory sensor characterization curve. Refer to [page 17](#).
- Analog output trim: Adjusts the transmitter's analog characterization curve to match the plant standard of the control loop. There are two types of digital-to-analog output trims. Refer to [page 68](#).
 - Digital-to-Analog output trim on 4–20 mA HART output ([page 69](#))
 - Digital-to-Analog output trim on 4–20 mA HART output using other scale ([page 70](#))
- Sensor trim: Adjusts the position of the factory sensor characterization curve due to a change in the sensor characteristics over time or a change in test equipment. Trimming has two steps, zero and sensor trims. Refer to [page 72](#) and [page 73](#).
- Zero trim ([page 72](#))
- Sensor trim ([page 73](#))

[Figure 4-1 on page 65](#) illustrates Rosemount 3051 Transmitter data flow. Data flow can be summarized in four major steps:

1. A change in pressure is measured by a change in the sensor output (sensor signal).
2. The sensor signal is converted to a digital format that is understood by the microprocessor (Analog-to-Digital Signal Conversion). Sensor trim functions affect this value. Select these options to alter the digital signal on the LCD or Field Communicator.
3. Corrections are performed in the microprocessor to obtain a digital representation of the process input (Digital PV).
4. The Digital PV is converted to an analog value (Digital-to-Analog signal conversion). Rerange and analog trim functions affect this value. Select these options to change the range points (4–20 mA or 1–5 Vdc).

For a summary of recommended calibration procedures, refer to [Table 4-1 on page 65](#). Also, [Figure 4-1 on page 65](#) identifies the approximate transmitter location for each calibration task. Data flows from left to right and a parameter change affects all values to the right of the changed parameter.

Figure 4-1. Transmitter Data Flow with Calibration Options

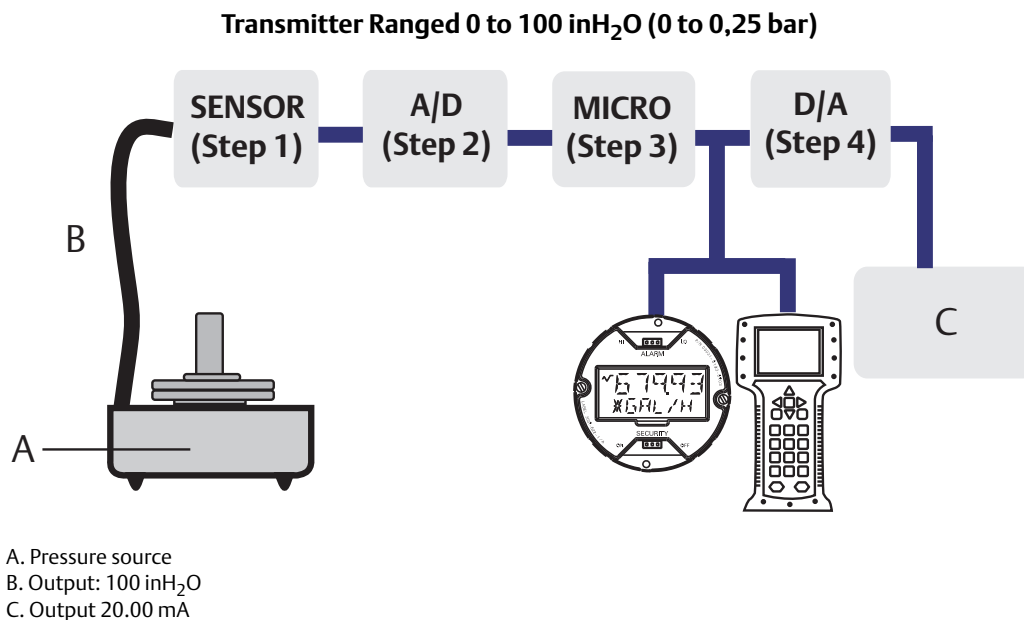

Table 4-1. Recommended Calibration Tasks

Transmitter	Bench calibration tasks	Field calibration tasks
3051CD, 3051CG, 3051L, 3051TG, Range 1-4	<ol style="list-style-type: none"> 1. Set output configuration parameters: <ol style="list-style-type: none"> a. Set the range points. b. Set the output units. c. Set the output type. d. Set the damping value. 2. Optional: Perform a sensor trim. (Accurate pressure source required.) 	<ol style="list-style-type: none"> 1. Reconfigure parameters if necessary. 2. Zero trim the transmitter to compensate for mounting effects or static pressure effects. 3. Optional: Perform an analog output trim. (Accurate multimeter required)
3051CA, 3051TA, 3051TG, Range 5	<ol style="list-style-type: none"> 1. Set output configuration parameters: <ol style="list-style-type: none"> a. Set the range points. b. Set the output units. c. Set the output type. d. Set the damping value. 2. Optional: Perform a sensor trim if equipment available (accurate absolute pressure source required), otherwise perform the low trim value section of the sensor trim procedure. 	<ol style="list-style-type: none"> 1. Reconfigure parameters if necessary. 2. Perform low trim value section of the sensor trim procedure to correct for mounting position effects. 3. Optional: Perform an analog output trim (Accurate multimeter required)

Note

The Rosemount 3051 has been carefully calibrated at the factory. Trimming adjusts the position of the factory characterization curve. It is possible to degrade performance of the transmitter if any trim is done improperly or with inaccurate equipment.

Note

A Field Communicator is required for all sensor and output trim procedures. Rosemount 3051C Range 4 and Range 5 Transmitters require a special calibration procedure when used in differential pressure applications under high static line pressure (see “Select Finish to acknowledge the method is complete.” on page 74).

4.3.1 Determining calibration frequency

Calibration frequency can vary greatly depending on the application, performance requirements, and process conditions. Use the following procedure to determine calibration frequency that meets the needs of your application.

1. Determine the performance required for your application.
2. Determine the operating conditions.
3. Calculate the Total Probable Error (TPE).
4. Calculate the stability per month.
5. Calculate the calibration frequency.

Sample calculation for a standard Rosemount 3051C

Step 1: Determine the performance required for your application.

Required performance: 0.30% of span

Step 2: Determine the operating conditions.

Transmitter: Rosemount 3051CD, Range 2 [URL=250 inH₂O(623 mbar)]
 Calibrated span: 150 inH₂O (374 mbar)
 Ambient temperature change: ± 50 °F (28 °C)
 Line pressure: 500 psig (34,5 bar)

Step 3: Calculate total probable error (TPE).

$$TPE = \sqrt{(\text{ReferenceAccuracy})^2 + (\text{TemperatureEffect})^2 + (\text{StaticPressureEffect})^2} = 0.117\% \text{ of span}$$

Where:

Reference accuracy = ± 0.065% of span

Ambient temperature effect = $\pm \left(\frac{0.0125 \times \text{URL}}{\text{Span}} + 0.0625 \right) \% \text{ per } 50 \text{ }^\circ\text{F} = \pm 0.0833\% \text{ of span}$

Span static pressure effect⁽¹⁾ =
 0.1% reading per 1000 psi (69 bar) = ±0.05% of span at maximum span

1. Zero static pressure effect removed by zero trimming at line pressure.

Step 4: Calculate the stability per month.

$$\text{Stability} = \pm \left[\frac{0.0125 \times \text{URL}}{\text{Span}} \right] \% \text{ of span for 5 years} = \pm 0.0035\% \text{ of span per month}$$

Step 5: Calculate calibration frequency.

$$\text{Cal. Freq.} = \frac{(\text{Req. Performance} - \text{TPE})}{\text{Stability per Month}} = \frac{(0.30\% - 0.117\%)}{0.0035\%} = (52) \text{ months}$$

Sample calculation for Rosemount 3051C with P8 option (0.04% accuracy & 5-year stability)

Step 1: Determine the performance required for your application.

Required performance: 0.30% of span

Step 2: Determine the operating conditions.

Transmitter: Rosemount 3051CD, Range 2 (URL=250 inH₂O [623 mbar])
 Calibrated span: 150 inH₂O (374 mbar)
 Ambient temperature change: ± 50 °F (28 °C)
 Line pressure: 500 psig (34,5 bar)

Step 3: Calculate total probable error (TPE).

$$TPE = \sqrt{(\text{ReferenceAccuracy})^2 + (\text{TemperatureEffect})^2 + (\text{StaticPressureEffect})^2} = 0.105\% \text{ of span}$$

Where:

Reference Accuracy = ± 0.04% of span

Ambient Temperature Effect =

$$\pm \left(\frac{0.0125 \times \text{URL}}{\text{Span}} + 0.0625 \right) \% \text{ per } 50 \text{ }^\circ\text{F} = \pm 0.0833\% \text{ of span}$$

Span Static Pressure Effect⁽¹⁾ =

$$0.1\% \text{ reading per } 1000 \text{ psi (69 bar)} = \pm 0.05\% \text{ of span at maximum span}$$

1. Zero static pressure effect removed by zero trimming at line pressure.

Step 4: Calculate the stability per month.

$$\text{Stability} = \pm \left[\frac{0.125 \times \text{URL}}{\text{Span}} \right] \% \text{ of span for 5 years} = \pm 0.0035\% \text{ of span per month}$$

Step 5: Calculate calibration frequency.

$$\text{Cal. Freq.} = \frac{(\text{Req. Performance} - \text{TPE})}{\text{Stability per Month}} = \frac{(0.3\% - 0.105\%)}{0.0035\%} = 27 \text{ months}$$

4.3.2 Selecting a trim procedure

To decide which trim procedure to use, you must first determine whether the analog-to-digital section or the digital-to-analog section of the transmitter electronics need calibration. Refer to [Figure 4-1](#) and perform the following procedure:

1. Connect a pressure source, a Field Communicator or AMS Device Manager, and a digital readout device to the transmitter.
2. Establish communication between the transmitter and the Field Communicator.
3. Apply pressure equal to the upper range point pressure.
4. Compare the applied pressure to the pressure process variable valve on the *Process Variables* menu on the Field Communicator or the *Process Variables* screen in AMS Device Manager. For instructions on how to access process variables, see [page 15](#) of [Section 2: Configuration](#).
 - a. If the pressure reading does not match the applied pressure (with high-accuracy test equipment), perform a sensor trim. See [“Sensor trim overview” on page 71](#) to determine which trim to perform.
5. Compare the Analog Output (AO) line, on the Field Communicator or AMS Device Manager, to the digital readout device.

If the AO reading does not match the digital readout device (with high-accuracy test equipment), perform an analog output trim. See [“Analog output trim” on page 68](#).

4.4 Analog output trim

The analog output trim commands allow you to adjust the transmitter’s current output at the 4 and 20 mA (1 and 5 Vdc) points to match the plant standards. This command adjusts the digital to analog signal conversion.

Figure 4-2. Output Trim

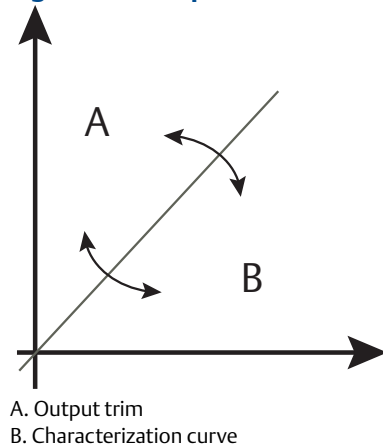

4.4.1 Digital-to-Analog trim Field Communicator

Traditional 4–20 mA Fast Keys	1, 2, 3, 2, 1
Traditional 1–5 Vdc Fast Keys	1, 2, 3, 2, 1
Device Dashboard Fast Keys	3, 4, 2

To perform a digital-to-analog trim with a Field Communicator, perform the following procedure.

1. From the *HOME* screen, enter the Fast Key sequence “Digital-to-Analog Trim”. Select **OK** after setting the control loop to manual, see “Setting the loop to manual” on page 4.
2. For 4–20 mA HART output, connect a reference meter to the transmitter by either connecting the meter to the test terminals on the terminal block, or shunting transmitter power through the meter at some point in the loop.

For 1–5 Vdc Low Power HART output, connect a reference meter to the V_{out} terminal.

3. Select **OK** after connecting the reference meter.
4. Select **OK** at the *SETTING FLD DEV OUTPUT TO 4 MA (1 Vdc)* prompt. The transmitter outputs 4.0 mA.
5. Record the actual value from the reference meter, and enter it at the *ENTER METER VALUE* prompt. The Field Communicator prompts you to verify whether or not the output value equals the value on the reference meter.
6. Select **1: Yes**, if the reference meter value equals the transmitter output value, or **2: No** if it does not.
 - a. If 1 is selected: Yes, proceed to [Step 7](#).
 - b. If 2 is selected: No, repeat [Step 5](#).
7. Select **OK** at the *SETTING FLD DEV OUTPUT TO 20 MA (5 Vdc)* prompt, and repeat steps 5 and 6 until the reference meter value equals the transmitter output value.
8. Select **OK** after the control loop is returned to automatic control.

AMS Device Manager

1. Right click on the device and select **Calibrate**, then **D/A trim** from the menu.
2. Select **Next** after setting the control loop to manual.
3. Select **Next** after connecting the reference meter.
4. Select **Next** at the *Setting fld dev output to 4 mA (1 Vdc)* screen.
5. Record the actual value from the reference meter, and enter it at the *Enter meter value* screen and select **Next**.
6. Select **Yes**, if the reference meter value equals the transmitter output value, or **No** if it does not. Select **Next**.
 - a. If Yes is selected, proceed to [Step 7](#).
 - b. If No is selected, repeat [Step 5](#).
7. Click **Next** at the *Setting fld dev output to 20 mA (5 Vdc)* screen.
8. Repeat steps 5–6 until the reference meter equals the transmitter output value.

9. Select **Next** to acknowledge the loop can be returned to automatic control.
10. Select **Finish** to acknowledge the method is complete.

4.4.2 Digital-to-Analog trim using other scale

The scaled D/A trim command matches the 4 and 20 mA (1 and 5 Vdc) points to a user selectable reference scale other than 4 and 20 mA (i.e. 2 to 10 volts if measuring across a 500 ohm load, or zero to 100 percent if measuring from a Distributed Control System [DCS]). To perform a scaled D/A trim, connect an accurate reference meter to the transmitter and trim the output signal to scale, as outlined in the output trim procedure.

Note

Use a precision resistor for optimum accuracy. If you add a resistor to the loop, ensure that the power supply is sufficient to power the transmitter to a 20 mA output with additional loop resistance. Refer to “Power supply for 4-20 mA HART” on page 48.

Field Communicator

Traditional 4–20 mA Fast Keys	1, 2, 3, 2, 2
Traditional 1–5 Vdc Fast Keys	1, 2, 3, 2, 2
Device Dashboard Fast Keys	3, 4, 2

AMS Device Manager

1. Right click on the device and select **Calibrate**, then **Scaled D/A trim** from the menu.
2. Select **Next** after setting the control loop to manual.
3. Select **Change** to change scale, select **Next**.
4. Enter Set scale-Lo output value, select **Next**.
5. Enter Set scale-Hi output value, select **Next**.
6. Select **Next** to proceed with Trim.
7. Select **Next** after connecting the reference meter.
8. Select **Next** at the *Setting fld dev output to 4 mA* screen.
9. Record the actual value from the reference meter, and enter it at the *Enter meter value* screen and select **Next**.
10. Select **Yes**, if the reference meter value equals the transmitter output value, or **No** if it does not. Select **Next**.
 - a. If Yes is selected, proceed to [Step 11](#).
 - b. If No is selected, repeat [Step 9](#).
11. Select **Next** at the *Setting fld dev output to 20 mA* screen.
12. Repeat steps 9–10 until the reference meter equals the transmitter output value.
13. Select **Next** to acknowledge the loop can be returned to automatic control.
14. Select **Finish** to acknowledge the method is complete.

4.4.3 Recall factory trim—analog output

The recall factory trim—analog output command allows the restoration of the as-shipped factory settings of the analog output trim. This command can be useful for recovering from an inadvertent trim, incorrect plant standard or faulty meter. This command is only available with 4-20 mA output.

Field Communicator

Traditional 4–20 mA Fast Keys	1, 2, 3, 4, 2
Device Dashboard Fast Keys	3, 4, 3

AMS Device Manager

1. Right click on the device and select **Calibrate**, then **Recall Factory Trim** from the menu.
1. Select **Next** after setting the control loop to manual.
2. Select **Analog output trim** under *Trim to recall* and select **Next**.
3. Select **Next** to acknowledge restoration of trim values is complete.
4. Select **Next** to acknowledge the loop can be returned to automatic control.
5. Select **Finish** to acknowledge the method is complete.

4.5 Sensor trim

4.5.1 Sensor trim overview

Trim the sensor using either sensor or zero trim functions. Trim functions vary in complexity and are application-dependent. Both trim functions alter the transmitter’s interpretation of the input signal.

Zero trim is a single-point offset adjustment. It is useful for compensating for mounting position effects and is most effective when performed with the transmitter installed in its final mounting position. Since this correction maintains the slope of the characterization curve, it should not be used in place of a sensor trim over the full sensor range.

When performing a zero trim, ensure that the equalizing valve is open and all wet legs are filled to the correct levels.

Note

Do not perform a zero trim on Rosemount 3051T Absolute Pressure Transmitters. Zero trim is zero based, and absolute pressure transmitters reference absolute zero. To correct mounting position effects on a Rosemount 3051T Absolute Pressure Transmitter, perform a low trim within the sensor trim function. The low trim function provides an offset correction similar to the zero trim function, but it does not require zero-based input.

Sensor trim is a two-point sensor calibration where two end-point pressures are applied, and all output is linearized between them. Always adjust the low trim value first to establish the correct offset. Adjustment of the high trim value provides a slope correction to the characterization curve based on the low trim value. The trim values allow you to optimize performance over your specified measuring range at the calibration temperature.

Figure 4-3. Sensor Trim

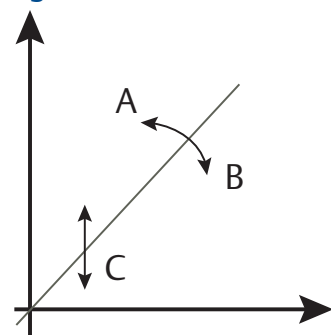

A. Upper sensor trim
B. Sensor characterization curve
C. Lower sensor trim

4.5.2 Zero trim

Note

The transmitter PV at zero pressure must be within three percent of URL in order to calibrate using the zero trim function.

Field Communicator

Traditional 4–20 mA Fast Keys	1, 2, 3, 3, 1
Traditional 1–5 Vdc Fast Keys	1, 2, 3, 3, 1
Device Dashboard Fast Keys	3, 4, 1, 3

Calibrate the sensor with a Field Communicator using the zero trim function as follows:

1. Vent the transmitter and attach a Field Communicator to the measurement loop.
2. From the *HOME* screen, follow the Fast Key sequence “Zero Trim”.
3. Follow the commands provided by the Field Communicator to complete the zero trim adjustment.

AMS Device anager

1. Right click on the device and select **Calibrate**, then **Zero trim** from the menu.
2. Select **Next** after setting the control loop to manual.
3. Select **Next** to acknowledge warning.
4. Select **Next** after applying appropriate pressure to sensor.
5. Select **Next** to acknowledge the loop can be returned to automatic control.
6. Select **Finish** to acknowledge the method is complete.

4.5.3 Sensor trim

Note

Use a pressure input source that is at least four times more accurate than the transmitter, and allow the input pressure to stabilize for ten seconds before entering any values.

Field Communicator

Traditional 4–20 mA Fast Keys	1, 2, 3, 3
Traditional 1–5 Vdc Fast Keys	1, 2, 3, 3
Device Dashboard Fast Keys	3, 4, 1

To calibrate the sensor with a Field Communicator using the sensor trim function, perform the following procedure:

1. Assemble and power the entire calibration system including a transmitter, Field Communicator, power supply, pressure input source, and readout device.
2. From the *HOME* screen, enter the Fast Key sequence under “Sensor Trim”.
3. Select **2: Lower sensor trim**. The lower sensor trim value should be the sensor trim point that is closest to zero.

Examples:

Calibration: 0 to 100 inH₂O – lower trim = 0, upper trim = 100

Calibration: –100 to 0 inH₂O – lower trim = 0, upper trim = –100

Calibration: –100 to 100 inH₂O – lower trim = –100 or 100, upper trim = –100 or 100

Note

Select pressure input values so that lower and upper values are equal to or outside the 4 and 20 mA (1 and 5 Vdc) points. Do not attempt to obtain reverse output by reversing the high and low points. This can be done by going to “[Rerange](#)” on page 17 of [Section 2: Configuration](#). The transmitter allows approximately five percent deviation.

4. Follow the commands provided by the Field Communicator to complete the adjustment of the lower value.
5. Repeat the procedure for the upper value, replacing **2: Lower sensor trim** with **3: Upper sensor trim** in [Step 3](#).

AMS Device Manager

1. Right click on the device and select **Calibrate**, then **Sensor trim** from the menu.
2. Select **Lower sensor trim**. The lower sensor trim value should be the sensor trim point that is closest to zero.
3. Select **Next** after setting the control loop to manual.
4. Select **Next** after applying appropriate pressure to sensor.
5. Select **Next** to acknowledge the loop can be returned to automatic control.
6. Select **Finish** to acknowledge the method is complete.
7. Right click on the device and select **Calibrate**, select **Sensor trim** from the menu.
8. Select **Upper sensor trim** and repeat [Step 6](#).

4.5.4 Recall factory trim—sensor trim

The recall factory trim—sensor trim command allows the restoration of the as-shipped factory settings of the sensor trim. This command can be useful for recovering from an inadvertent zero trim of an absolute pressure unit or inaccurate pressure source. This command is only available with 4-20 mA output.

Field Communicator

4–20 mA Fast Keys	1, 2, 3, 4, 1
Device Dashboard Fast Keys	3, 4, 3

AMS Device Manager

1. Right click on the device and select **Calibrate**, then **Recall Factory Trim** from the menu.
2. Select **Next** after setting the control loop to manual.
3. Select **Sensor trim** under *Trim to recall* and click **Next**.
4. Select **Next** to acknowledge restoration of trim values is complete.
5. Select **Next** to acknowledge the loop can be returned to automatic control.
6. Select **Finish** to acknowledge the method is complete.

4.5.5 Line pressure effect (range 2 and 3)

The following specifications show the static pressure effect for the Rosemount 3051 Range 2 and Range 3 Pressure Transmitters used in differential pressure applications where line pressure exceeds 2000 psi (138 bar).

Zero effect

±0.1% of the upper range limit plus an additional ±0.1% of upper range limit error for each 1000 psi (69 bar) of line pressure above 2000 psi (138 bar).

Example: Line pressure is 3000 psi (207 bar) for Ultra performance transmitter. Zero effect error calculation:

$$\pm\{0.05 + 0.1 \times [3 \text{ kpsi} - 2 \text{ kpsi}]\} = \pm 0.15\% \text{ of the upper range limit}$$

Span effect

Refer to “Line pressure effect per 1000 psi (6,9 MPa)” on page 91.

4.5.6 Compensating for line pressure

Rosemount 3051 Range 4 and 5 Pressure Transmitters require a special calibration procedure when used in differential pressure applications. The purpose of this procedure is to optimize transmitter performance by reducing the effect of static line pressure in these applications. The differential pressure transmitters (Ranges 1, 2, and 3) do not require this procedure because optimization occurs in the sensor.

Applying high static pressure to Rosemount 3051 Range 4 and 5 Pressure Transmitters causes a systematic shift in the output. This shift is linear with static pressure; correct it by performing the sensor trim procedure on page 73.

The following specifications show the static pressure effect for Rosemount 3051 Range 4 and 5 Transmitters used in differential pressure applications:

Zero effect

$\pm 0.1\%$ of the upper range limit per 1000 psi (69 bar) for line pressures from 0 to 2000 psi (0 to 138 bar)

For line pressures above 2000 psi (138 bar), the zero effect error is $\pm 0.2\%$ of the upper range limit plus an additional $\pm 0.2\%$ of upper range limit error for each 1000 psi (69 bar) of line pressure above 2000 psi (138 bar).

Example: Line pressure is 3000 psi (3 kpsi). Zero effect error calculation:

$\pm \{0.2 + 0.2 \text{ mm} \times [3 \text{ kpsi} - 2 \text{ kpsi}]\} = \pm 0.4\%$ of the upper range limit

Span effect

Correctable to $\pm 0.2\%$ of reading per 1000 psi (69 bar) for line pressures from 0 to 3626 psi (0 to 250 bar)

The systematic span shift caused by the application of static line pressure is -1.00% of reading per 1000 psi (69 bar) for Range 4 transmitters, and -1.25% of reading per 1000 psi (69 bar) for Range 5 transmitters.

Use the following example to compute corrected input values.

Example

A Range 4 transmitter with model number 3051_CD4 will be used in a differential pressure application where the static line pressure is 1200 psi (83 bar). The transmitter output is ranged with 4 mA at 500 inH₂O (1.2 bar) and 20 mA at 1500 inH₂O (3.7 bar).

To correct for systematic error caused by high static line pressure, first use the following formulas to determine corrected values for the low trim and high trim.

Low trim value

$$LT = LRV - (S/100 \times P/1000 \times LRV)$$

Where:	LT =	Corrected low trim value
	LRV =	Lower range value
	S =	Span shift per specification (as a percent of reading)
	P =	Static line pressure in psi

In this example:

LRV =	500 inH ₂ O (1.24 bar)
S =	-1.00%
P =	1200 psi
LT =	500 inH ₂ O - (-1%/100 × 1200 psi/1000 × 500 inH ₂ O)
LT =	506 inH ₂ O

High trim value

$$HT = (URV - (S/100 \times P/1000 \times URV))$$

Where:	HT =	Corrected high trim value
	URV =	Upper range value
	S =	Span shift per specification (as a percent of reading)
	P =	Static line pressure in psi

In this example:

URV =	1500 inH ₂ O (3.74 bar)
S =	-1.00%
P =	1200 psi
HT =	1500 - (-1%/100 × 1200 psi/1000 × 1500 inH ₂ O)
HT =	1518 inH ₂ O

Complete the sensor trim procedure as described on [page 73](#). In the example above, at step 4, apply the nominal pressure value of 500 inH₂O. However, enter the calculated correct lower trim (LT) value of 506 inH₂O with the Field Communicator. Repeat the procedure for the upper value.

Note

The range values for the 4 and 20 mA (1 and 5 Vdc) points should be at the nominal URV and LRV. In the example above, the values are 1500 inH₂O and 500 inH₂O respectively. Confirm the values on the *HOME* screen on the Field Communicator. Modify, if needed, by following the steps in the “[Rerange](#)” on [page 17](#).

Section 5 Troubleshooting

Overview	page 77
Safety messages	page 77
Diagnostic messages	page 79
Disassembly procedures	page 84
Reassembly procedures	page 85

5.1 Overview

Table 5-1 provides summarized maintenance and troubleshooting suggestions for the most common operating problems.

If you suspect malfunction despite the absence of any diagnostic messages on the Field Communicator display, consider using Table 5-1 on page 78 to identify any potential problem.

5.2 Safety messages

Procedures and instructions in this section may require special precautions to ensure the safety of the personnel performing the operations. Information that raises potential safety issues is indicated by a warning symbol (⚠). Refer to the following safety messages before performing an operation preceded by this symbol.

⚠ WARNING

Explosions could result in death or serious injury.

Installation of this transmitter in an explosive environment must be in accordance with the appropriate local, national, and international standards, codes, and practices. Review the approvals section of this manual for any restrictions associated with a safe installation.

- Before connecting a Field Communicator in an explosive atmosphere, ensure the instruments in the loop are installed in accordance with intrinsically safe or non-incendive field wiring practices.
- In an Explosion-Proof/Flameproof installation, do not remove the transmitter covers when power is applied to the unit.

Process leaks may cause harm or result in death.

- Install and tighten process connectors before applying pressure.

Electrical shock can result in death or serious injury.

- Avoid contact with the leads and terminals. High voltage that may be present on leads can cause electrical shock.
-

Table 5-1. Troubleshooting for 4-20 mA output

Symptom	Corrective actions
Transmitter milliamp reading is zero	Verify power is applied to signal terminals
	Check power wires for reversed polarity
	Verify terminal voltage is 10.5 to 42.4 Vdc
	Check for open diode across test terminal
Transmitter not communicating with Field Communicator	Verify the output is between 4 and 20 mA or saturation levels
	Verify terminal voltage is 10.5 to 42.4 Vdc
	Verify clean DC Power to transmitter (Max AC noise 0.2 volts peak to peak)
	Check loop resistance, 250 Ω minimum (PS voltage -transmitter voltage/loop current)
	Have Field Communicator poll for all addresses
Transmitter milliamp reading is low or high	Verify applied pressure
	Verify 4 and 20 mA range points
	Verify output is not in alarm condition
	Verify if 4–20 mA output trim is required
Transmitter will not respond to changes in applied pressure	Check test equipment
	Check impulse piping or manifold for blockage
	Verify the transmitter is not in multidrop mode
	Verify applied pressure is between the 4 and 20 mA set points
	Verify output is not in alarm condition
	Verify transmitter is not in Loop Test mode
Digital pressure variable reading is low or high	Check test equipment (verify accuracy)
	Check impulse piping for blockage or low fill in wet leg
	Verify transmitter is calibrated properly
	Verify pressure calculations for application
Digital pressure variable reading is erratic	Check application for faulty equipment in pressure line
	Verify transmitter is not reacting directly to equipment turning on/off
	Verify damping is set properly for application
Milliamp reading is erratic	Verify power source to transmitter has adequate voltage and current
	Check for external electrical interference
	Verify transmitter is properly grounded
	Verify shield for twisted pair is only grounded at one end

5.3 Diagnostic messages

In addition to the output, the LCD display meter shows abbreviated operation, error, and warning messages for troubleshooting the transmitter. Messages appear according to their priority, with normal operating messages appearing last. To determine the cause of a message, use a Field Communicator or AMS Device Manager to further interrogate the transmitter. A description of each LCD display diagnostic message follows.

Error

Error messages appear on the LCD display to inform you of serious problems affecting the operation of the transmitter. The LCD displays an error message until the error condition is corrected, and the analog output is driven to the specified alarm level. No other transmitter information is displayed during an alarm condition.

Fail

The transmitter CPU board and the sensor module are incompatible. See [“Disassembly procedures” on page 84](#).

Fail Module

The sensor module is disconnected or is malfunctioning. Verify that the sensor module ribbon cable is connected to the back of the electronics board. If the ribbon cable is properly connected, there is a problem within the sensor module. Possible sources of problems include:

- Pressure or temperature updates are not being received in the sensor module.
- A non-volatile memory fault that will effect transmitter operation has been detected in the module by the memory verification routine.

Some non-volatile memory faults are user-repairable. Use a Field Communicator to diagnose the error and determine if it is repairable. Any error message that ends in “FACTORY” is not repairable. In cases of non user-repairable errors, you must replace the transmitter.

Fail Elect

The transmitter electronics board is malfunctioning due to an internal fault. Some of the FAIL ELECT errors are user-repairable. Use a Field Communicator to diagnose the error and determine if it is repairable. Any error message that ends in “FACTORY” is not repairable. In cases of non user-repairable errors, you must replace the electronics board. See [“Disassembly procedures” on page 84](#).

Fail Config

A memory fault has been detected in a location that could affect transmitter operation, and is user-accessible. To correct this problem, use a Field Communicator to interrogate and reconfigure the appropriate portion of the transmitter memory.

Warnings

Warnings appear on the LCD display to alert you of user-repairable problems with the transmitter, or current transmitter operations. Warnings appear alternately with other transmitter information until the warning condition is corrected or the transmitter completes the operation that warrants the warning message.

Press Limit

The process variable read by the transmitter is outside of the transmitter’s range.

Temp Limit

The secondary temperature variable read by the transmitter is outside of the transmitter's range.

Curr Fixed

The transmitter is in multidrop mode. The analog output is not tracking pressure changes.

Curr Saturd

The pressure read by the module is outside of the specified range, and the analog output has been driven to saturation levels.

Loop Test

A loop test is in progress. During a loop test or 4–20 mA trim, the analog output is set to a fixed value. The meter display alternates between the current selected in milliamps and "LOOP TEST."

Xmtr Info

A non-volatile memory fault has been detected in the transmitter memory by the memory verification routine. The memory fault is in a location containing transmitter information. To correct this problem, use a Field Communicator to interrogate and reconfigure the appropriate portion of the transmitter memory. This warning does not effect the transmitter operation.

Operation

Normal operation messages appear on the LCD display meter to confirm actions or inform you of transmitter status. Operation messages are displayed with other transmitter information, and warrant no action to correct or alter the transmitter settings.

Zero Pass

The zero value, set with the local zero adjustment button, has been accepted by the transmitter, and the output should change to 4 mA (1 Vdc).

Zero Fail

The zero value, set with the local zero adjustment button, exceeds the maximum rangedown allowed for a particular range, or the pressure sensed by the transmitter exceeds the sensor limits.

Span Pass

The span value, set with the local span adjustment button, has been accepted by the transmitter, and the output should change to 20 mA (5 Vdc).

Span Fail

The span value, set with the local span adjustment button, exceeds the maximum rangedown allowed for a particular range, or the pressure sensed by the transmitter exceeds the sensor limits.

Local Dsbl

This message appears during reranging with the integral zero and span buttons and indicates that the transmitter local zero and span adjustments have been disabled. The adjustments may have been disabled by the transmitter security jumper on the transmitter circuit board or through software commands from the Field Communicator. See "[Security \(write protect\)](#)" on page 44 for information on the position of the security jumper and information on software lockout.

Write Protect

This message appears if you attempt to change the transmitter configuration data while the security jumper is in the ON position. See “Security (write protect)” on page 44 for more information about the security jumper.

Field Communicator diagnostics

Table 5-2 is a list of messages used by the Field Communicator (HC) and their corresponding descriptions.

Variable parameters within the text of a message are indicated with *<variable parameter>*.

Reference to the name of another message is identified by *[another message]*.

Table 5-2. Field Communicator Messages

Message	Description
1k snsr EEPROM error-factory ON	Replace the transmitter
1k snsr EEPROM error-user-no out ON	Use the Field Communicator to reset the following parameters: remote seal isolator, remote seal fill fluid, flange material, o-ring material, transmitter type, remote seal type, flange type, meter type, number of remote seals.
1k snsr EEPROM error-user ON	Perform a full trim to recalibrate the transmitter.
4k micro EEPROM error-factory ON	Replace the electronics board.
4k micro EEPROM error-user-no out ON	Use the Field Communicator to reset the message field.
4k micro EEPROM error-user ON	Use the Field Communicator to reset the following parameters: units, range values, damping, analog output, transfer function, tag, scaled meter values. Perform a D/A trim to ensure that the error is corrected.
4k snsr EEPROM error-factory ON	Replace the transmitter.
4k snsr EEPROM error-user ON	Use the Field Communicator to reset the temperature units and the calibration type.
Add item for ALL device types or only for this ONE device type.	Asks the user whether the hot key item being added should be added for all device types or only for the type of device that is connected.
Command Not Implemented	The connected device does not support this function.
Communication Error	The communicator and the device are not communicating correctly. Check all connections between the Field Communicator and the device and resend the information.
Configuration memory not compatible with connected device	The configuration stored in memory is incompatible with the device to which a transfer has been requested.
CPU board not initialized ON	The electronics board is not initialized. Replace the electronics board.
CPU EEPROM write failure ON	Message sent to electronics board from HART® signal failed. Replace the electronics board.
Device Busy	The connected device is busy performing another task.

Message	Description
Device Disconnected	The device failed to respond to a command. Check all connections between the Field Communicator and the device and resend the command.
Device write protected	Device is in write-protect mode. Data can not be written.
Device write protected. Do you still want to shut off?	Device is in write-protect mode. Press YES to turn the Field Communicator off and lose the unsent data.
Display value of variable on hotkey menu?	Asks whether the value of the variable should be displayed adjacent to its label on the hotkey menu if the item being added to the hotkey menu is a variable.
Download data from configuration memory to device	Press the SEND softkey to transfer information from the communicator memory to the device.
Exceed field width	Indicates that the field width for the current arithmetic variable exceeds the device-specified description edit format.
Exceed precision	Indicates that the precision for the current arithmetic variable exceeds the device-specified description edit format.
Ignore next 50 occurrences of status?	Select YES to ignore the next 50 occurrences of device status, or select NO to display every occurrence.
Illegal character	An invalid character for the variable type was entered.
Illegal date	The day portion of the date is invalid.
Illegal month	The month portion of the date is invalid.
Illegal year	The year portion of the date is invalid.
Incompatible CPU board and module ON	Upgrade the electronics board or the sensor module to the current revision.
Incomplete exponent	The exponent of a scientific notation floating point variable is incomplete.
Incomplete field	The value entered is not complete for the variable type.
Looking for a device	Polling for multidropped devices at addresses 1–15.
Local buttons operator error ON	Illegal pressure applied during zero or span operation. Repeat the process after verifying the correct pressures.
Mark as read only variable on hotkey menu?	Asks whether the user should be allowed to edit the variable from the hotkey menu if the item being added to the hotkey menu is a variable.
Module EEPROM write failure ON	Message sent to the module from the HART signal failed. Replace the transmitter.
No device configuration in configuration memory	There is no configuration saved in memory available to re-configure off-line or transfer to a device.
No Device Found	Poll of address zero fails to find a device, or poll of all addresses fails to find a device if auto-poll is enabled.
No hotkey menu available for this device.	There is no menu named “hotkey” defined in the device description for this device.
No pressure updates ON	No pressure updates being received from the sensor module. Verify that the sensor module ribbon cable is attached correctly. Or replace the transmitter.
No offline devices available.	There are no device descriptions available to be used to configure a device offline.
No simulation devices available.	There are no device descriptions available to simulate a device.

Message	Description
No temperature updates ON	No temperature updates being received from the sensor module. Verify that the sensor module ribbon cable is attached correctly. Or replace the transmitter.
No UPLOAD_VARIABLES in ddl for this device	There is no menu named "upload_variables" defined in the device description for this device. This menu is required for offline configuration.
No Valid Items	The selected menu or edit display contains no valid items.
OFF KEY DISABLED	Appears when the user attempts to turn the HC off before sending modified data or before completing a method.
Online device disconnected with unsent data. RETRY or OK to lose data.	There is unsent data for a previously connected device. Press RETRY to send data, or press OK to disconnect and lose unsent data.
Out of memory for hotkey configuration. Delete unnecessary items.	There is no more memory available to store additional hotkey items. Unnecessary items should be deleted to make space available.
Overwrite existing configuration memory	Requests permission to overwrite existing configuration either by a device-to-memory transfer or by an offline configuration. User answers using the softkeys.
Press OK...	Press the OK softkey. This message usually appears after an error message from the application or as a result of HART communications.
Restore device value?	The edited value that was sent to a device was not properly implemented. Restoring the device value returns the variable to its original value.
ROM checksum error ON	Checksum of transmitter software has detected a fault. Replace the electronics board.
Save data from device to configuration memory	Prompts user to press SAVE softkey to initiate a device-to-memory transfer.
Saving data to configuration memory.	Data is being transferred from a device to configuration memory.
Sending data to device.	Data is being transferred from configuration memory to a device.
Sensor board not initialized ON	The sensor module electronics board is not initialized. Replace the transmitter.
There are write only variables which have not been edited. Please edit them.	There are write-only variables which have not been set by the user. These variables should be set or invalid values may be sent to the device.
There is unsent data. Send it before shutting off?	Press YES to send unsent data and turn the HC off. Press NO to turn the HC off and lose the unsent data.
Too few data bytes received	Command returns fewer data bytes than expected as determined by the device description.
Transmitter Fault	Device returns a command response indicating a fault with the connected device.
Units for <variable label> has changed. Unit must be sent before editing, or invalid data will be sent.	The engineering units for this variable have been edited. Send engineering units to the device before editing this variable.
Unsent data to online device. SEND or LOSE data	There is unsent data for a previously connected device which must be sent or thrown away before connecting to another device.
Upgrade 275 software to access XMTR function. Continue with old description?	The communicator does not contain the most recent Rosemount™ 3051 Pressure Transmitter Device Descriptors (DDs). Select YES to communicate using the existing DDs. Select NO to abort communication.

Message	Description
Use up/down arrows to change contrast. Press DONE when done.	Gives direction to change the contrast of the HC display.
Value out of range	The user-entered value is either not within the range for the given type and size of variable or not within the min/max specified by the device.
<message> occurred reading/writing <variable label>	Either a read/write command indicates too few data bytes received, transmitter fault, invalid response code, invalid response command, invalid reply data field, or failed pre- or post-read method; or a response code of any class other than SUCCESS is returned reading a particular variable.
<variable label> has an unknown value. Unit must be sent before editing, or invalid data will be sent.	A variable related to this variable has been edited. Send related variable to the device before editing this variable.

5.4 Disassembly procedures

 Do not remove the instrument cover in explosive atmospheres when the circuit is live.

5.4.1 Remove from service

Follow these steps:

- Follow all plant safety rules and procedures.
- Isolate and vent the process from the transmitter before removing the transmitter from service.
- Remove all electrical leads and disconnect conduit.
- Remove the transmitter from the process connection.
- The Rosemount 3051C Transmitter is attached to the process connection by four bolts and two cap screws. Remove the bolts and separate the transmitter from the process connection. Leave the process connection in place and ready for re-installation.
- The Rosemount 3051T Transmitter is attached to the process by a single hex nut process connection. Loosen the hex nut to separate the transmitter from the process. Do not wrench on neck of transmitter.
- Do not scratch, puncture, or depress the isolating diaphragms.
- Clean isolating diaphragms with a soft rag and a mild cleaning solution, and rinse with clear water.
- For the Rosemount 3051C, whenever you remove the process flange or flange adapters, visually inspect the PTFE O-rings. Replace the O-rings if they show any signs of damage, such as nicks or cuts. Undamaged O-rings may be reused.

5.4.2 Remove terminal block

Electrical connections are located on the terminal block in the compartment labeled “FIELD TERMINALS.”

1. Remove the housing cover from the field terminal side.
2. Loosen the two small screws located on the assembly in the 9 o’clock and 5 o’clock positions.
3. Pull the entire terminal block out to remove it.

 See “Safety messages” on page 77 for complete warning information.

5.4.3 Remove the electronics board

The transmitter electronics board is located in the compartment opposite the terminal side. To remove the electronics board perform the following procedure:

1. Remove the housing cover opposite the field terminal side.
2. If you are disassembling a transmitter with a LCD display, loosen the two captive screws that are visible on the right and left side of the meter display.
- ⚠ 3. Loosen the two captive screws that anchor the board to the housing. The electronics board is electrostatically sensitive; observe handling precautions for static-sensitive components. Use caution when removing the LCD display as there is an electronic pin connector that interfaces between the LCD display and electronics board. The two screws anchor the LCD display to the electronics board and the electronics board to the housing.
4. Using the two captive screws, slowly pull the electronics board out of the housing. The sensor module ribbon cable holds the electronics board to the housing. Disengage the ribbon cable by pushing the connector release.

5.4.4 Remove the sensor module from the electronics housing

1. Remove the electronics board. Refer to “Remove the electronics board” on page 85.

Important

To prevent damage to the sensor module ribbon cable, disconnect it from the electronics board before you remove the sensor module from the electrical housing.

2. Carefully tuck the cable connector completely inside of the internal black cap.

Note

Do not remove the housing until after you tuck the cable connector completely inside of the internal black cap. The black cap protects the ribbon cable from damage that can occur when you rotate the housing.

3. Loosen the housing rotation set screw with a $5/64$ -in. hex wrench, and loosen one full turn.
4. Unscrew the module from the housing, making sure the black cap and sensor cable do not catch on the housing.

5.5 Reassembly procedures

1. Inspect all cover and housing (non-process wetted) O-rings and replace if necessary. Lightly grease with silicone lubricant to ensure a good seal.
2. Carefully tuck the cable connector completely inside the internal black cap. To do so, turn the black cap and cable counterclockwise one rotation to tighten the cable.
3. Lower the electronics housing onto the module. Guide the internal black cap and cable through the housing and into the external black cap.
4. Turn the module clockwise into the housing.

Important

Make sure the sensor ribbon cable and internal black cap remain completely free of the housing as you rotate it. Damage can occur to the cable if the internal black cap and ribbon cable become hung up and rotate with the housing.

- ⚠ 5. Thread the housing completely onto the sensor module. The housing must be no more than one full turn from flush with the sensor module to comply with explosion proof requirements.
6. Tighten the housing rotation set screw using a $\frac{5}{64}$ -in. hex wrench.

5.5.1 Attach the electronics board

1. Remove the cable connector from its position inside of the internal black cap and attach it to the electronics board.
2. Using the two captive screws as handles, insert the electronics board into the housing. Make sure the posts from the electronics housing properly engage the receptacles on the electronics board. Do not force. The electronics board should slide gently on the connections.
3. Tighten the captive mounting screws.
- ⚠ 4. Replace the electronics housing cover. The transmitter covers must be engaged metal-to-metal to ensure a proper seal and to meet Explosionproof requirements.

5.5.2 Install the terminal block

1. Gently slide the terminal block into place, making sure the two posts from the electronics housing properly engage the receptacles on the terminal block.
2. Tighten the captive screws.
3. Replace the electronics housing cover. The transmitter covers must be fully engaged to meet Explosion-Proof requirements.

5.5.3 Reassemble the Rosemount 3051C process flange

1. Inspect the sensor module PTFE o-rings. Undamaged o-rings may be reused. Replace o-rings that show any signs of damage, such as nicks, cuts, or general wear.

Note

If you are replacing the O-rings, be careful not to scratch the o-ring grooves or the surface of the isolating diaphragm when removing the damaged O-rings.

⚠ See “Safety messages” on page 77 for complete warning information.

2. Install the process connection. Possible options include:
 - a. Coplanar process flange:
 - Hold the process flange in place by installing the two alignment screws to finger tightness (screws are not pressure retaining). Do not overtighten as this will affect module-to-flange alignment.
 - Install the four 1.75-in. flange bolts by finger tightening them to the flange.
 - b. Coplanar process flange with flange adapters:
 - Hold the process flange in place by installing the two alignment screws to finger tightness (screws are not pressure retaining). Do not overtighten as this will affect module-to-flange alignment.
 - Hold the flange adapters and adapter o-rings in place while installing the four configurations, use four 2.88-in. bolts. For gage pressure configurations, use two 2.88-in. bolts and two 1.75-in. bolts.
 - c. Manifold:
 - Contact the manifold manufacturer for the appropriate bolts and procedures.
3. Tighten the bolts to the initial torque value using a crossed pattern. See [Table 5-3](#) for appropriate torque values.

Table 5-3. Bolt Installation Torque Values

Bolt material	Initial torque value	Final torque value
CS-ASTM-A445 standard	300 in-lb. (34 N-m)	650 in-lb. (73 N-m)
316 SST—option L4	150 in-lb. (17 N-m)	300 in-lb. (34 N-m)
ASTM-A-19 B7M—option L5	300 in-lb. (34 N-m)	650 in-lb. (73 N-m)
ASTM-A-193 Class 2, Grade B8M—option L8	150 in-lb. (17 N-m)	300 in-lb. (34 N-m)

Note

If you replaced the PTFE sensor module O-rings, re-torque the flange bolts after installation to compensate for cold flow.

Note

After replacing O-rings on Range 1 transmitters and re-installing the process flange, expose the transmitter to a temperature of 185 °F (85 °C) for two hours. Then re-tighten the flange bolts in a cross pattern, and again expose the transmitter to a temperature of 185 °F (85 °C) for two hours before calibration.

Appendix A Specifications and Reference Data

Performance specifications	page 89
Functional specifications	page 93
Physical specifications	page 99
Dimensional drawings	page 101
Ordering information	page 113
Options	page 130
Spare parts	page 136

A.1 Performance specifications

This product data sheet covers both HART® and FOUNDATION™ Fieldbus protocols unless specified.

A.1.1 Conformance to specification ($\pm 3\sigma$ [Sigma])

Technology leadership, advanced manufacturing techniques and statistical process control ensure specification conformance to at least $\pm 3\sigma$.

A.1.2 Reference accuracy

Rosemount models ⁽¹⁾	Standard	High accuracy option
3051CD, 3051CG Range 0 (CD)	$\pm 0.10\%$ of span For spans less than 2:1, accuracy = $\pm 0.05\%$ of URL	N/A
Range 1	$\pm 0.10\%$ of span For spans less than 15:1, accuracy = $\pm \left[0.025 + 0.005 \left(\frac{URL}{Span} \right) \right] \% \text{ of Span}$	N/A
Ranges 2–5	$\pm 0.065\%$ of span For spans less than 10:1, accuracy = $\pm \left[0.015 + 0.005 \left(\frac{URL}{Span} \right) \right] \% \text{ of Span}$	Ranges 2–4 High accuracy option, P8 $\pm 0.04\%$ of span For spans less than 5:1, accuracy = $\pm \left[0.015 + 0.005 \left(\frac{URL}{Span} \right) \right] \% \text{ of Span}$
3051T Ranges 1–4	$\pm 0.065\%$ of span For spans less than 10:1, accuracy = $\pm \left[0.0075 \left(\frac{URL}{Span} \right) \right] \% \text{ of Span}$	Ranges 1–4 High accuracy option, P8 $\pm 0.04\%$ of span For spans less than 5:1, accuracy = $\pm \left[0.0075 \left(\frac{URL}{Span} \right) \right] \% \text{ of Span}$
Range 5	$\pm 0.075\%$ of span	N/A

3051CA Ranges 1-4	±0.065% of span For spans less than 10:1, accuracy = $\pm \left[0.0075 \left(\frac{URL}{Span} \right) \right] \% \text{ of Span}$	Ranges 2-4 High Accuracy Option, P8 ±0.04% of span For spans less than 5:1, accuracy = $\pm \left[0.0075 \left(\frac{URL}{Span} \right) \right] \% \text{ of Span}$
3051H/3051L All ranges	±0.075% of span For spans less than 10:1, accuracy = $\pm \left[0.025 + 0.005 \left(\frac{URL}{Span} \right) \right] \% \text{ of Span}$	N/A

1. Total performance is determined by performing a root sum square calculation on reference accuracy, ambient temperature effect, and line pressure effect errors. For FOUNDATION Fieldbus transmitters, use calibrated range in place of span. For zero based spans, reference conditions, silicone oil fill, SST materials, Coplanar flange (Rosemount 3051C) or 1/2 in. - 18 NPT (Rosemount 3051T) process connections, digital trim values set to equal range points.

A.1.3 Total performance

For ±50 °F (28 °C) temperature changes, up to 1000 psi (6,9 MPa) line pressure (CD only), from 1:1 to 5:1 rangedown.

Rosemount models	Total performance
3051C Ranges 2-5	±0.15% of span
3051T Ranges 1-4	±0.15% of span

A.1.4 Long term stability

Rosemount models	Long term stability
3051C Ranges 2-5	±0.125% of URL for five years ±50 °F (28 °C) temperature changes, and up to 1000 psi (6,9 MPa) line pressure.
3051CD Low/Draft Range Ranges 0-1	±0.2% of URL for one year
3051T Ranges 1-4	±0.125% of URL for one years ±50 °F (28 °C) temperature changes, and up to 1000 psi (6,9 MPa) line pressure.
3051H Ranges 2-3 Ranges 4-5	±0.1% of URL for 1 year ±0.2% of URL for 1 year

A.1.5 Dynamic performance

	4–20 mA (HART protocol) ⁽¹⁾	Fieldbus protocol ⁽²⁾	Typical HART transmitter response time
Total response time ($T_d + T_c$) ⁽³⁾ :			<p>Transmitter Output vs. Time</p> <p>Pressure Released</p> <p>100%</p> <p>36.8%</p> <p>0%</p> <p>Time</p> <p>$T_d = \text{Dead Time}$</p> <p>$T_c = \text{Time Constant}$</p> <p>Response Time = $T_d + T_c$</p> <p>63.2% of Total Step Change</p>
Rosemount 3051C, Ranges 2–5:	100 ms	152 ms	
Range 1:	255 ms	307 ms	
Range 0:	700 ms	752 ms	
Rosemount 3051T:	100 ms	152 ms	
Rosemount 3051H/L:	Consult factory	Consult factory	
Dead time (T_d)	45 ms (nominal)	97 ms	
Update rate	22 times per second	22 times per second	

1. Dead time and update rate apply to all models and ranges; analog output only
2. Transmitter Fieldbus output only, segment macro-cycle not included.
3. Nominal total response time at 75 °F (24 °C) reference conditions.

A.1.6 Line pressure effect per 1000 psi (6,9 MPa)

Rosemount models ⁽¹⁾	Line pressure effect
3051CD	
Range 0	Zero error ⁽²⁾ ±0.125% of URL/100 psi (6,89 bar)
Range 1	±0.25% of URL/1000 psi (68,9 bar)
Ranges 2–3	±0.05% of URL/1000 psi (68,9 bar) for line pressures from 0 to 2000 psi (0 to 13,7 MPa)
Range 0	Span error ±0.15% of reading/100 psi (6,89 bar)
Range 1	±0.4% of reading/1000 psi (68,9 bar)
Ranges 2–3	±0.1% of reading/1000 psi (68,9 bar)
3051HD	i (68,9 bar) for line pressures from 0 to 2000 psi (0 to 13,7 MPa)
All ranges	Zero error ⁽¹⁾ ±0.1% of URL/1000 ps
All ranges	Span error ±0.1% of reading/1000 psi (68,9 bar)

1. For zero error specifications for line pressures above 2000 psi (137,9 bar) or line pressure effect specifications for DP Ranges 4-5, see “Compensating for line pressure” on page 75.
2. Can be calibrated out at line pressure.

A.1.7 Ambient temperature effect per 50 °F (28 °C)

Rosemount models	Ambient temperature effect
3051CD/CG	
Range 0	±(0.25% URL + 0.05% span)
Range 1	±(0.1% URL + 0.25% span)
Ranges 2–5	±(0.0125% URL + 0.0625% span) from 1:1 to 5:1 ±(0.025% URL + 0.125% span) from 5:1 to 100:1

Rosemount models	Ambient temperature effect
3051T	
Range 1	$\pm(0.025\% \text{ URL} + 0.125\% \text{ span})$ from 1:1 to 10:1 $\pm(0.05\% \text{ URL} + 0.125\% \text{ span})$ from 10:1 to 100:1
Range 2–4	$\pm(0.025\% \text{ URL} + 0.125\% \text{ span})$ from 1:1 to 30:1 $\pm(0.035\% \text{ URL} + 0.125\% \text{ span})$ from 30:1 to 100:1
Range 5	$\pm(0.1\% \text{ URL} + 0.15\% \text{ span})$
3051CA	
All ranges	$\pm(0.025\% \text{ URL} + 0.125\% \text{ span})$ from 1:1 to 30:1 $\pm(0.035\% \text{ URL} + 0.125\% \text{ span})$ from 30:1 to 100:1
3051H	
All ranges	$\pm(0.025\% \text{ URL} + 0.125\% \text{ span} + 0.35 \text{ inH}_2\text{O})$ from 1:1 to 30:1 $\pm(0.035\% \text{ URL} + 0.125\% \text{ span} + 0.35 \text{ inH}_2\text{O})$ from 1:1 to 30:1
3051L	See Emerson Process Management Instrument Toolkit™ software.

A.1.8 Mounting position effects

Rosemount models	Mounting position effects
3051C	Zero shifts up to $\pm 1.25 \text{ inH}_2\text{O}$ (3,11 mbar), which can be calibrated out. No span effect.
3051H	Zero shifts up to $\pm 5 \text{ inH}_2\text{O}$ (12,43 mbar), which can be calibrated out. No span effect.
3051L	With liquid level diaphragm in vertical plane, zero shift of up to $1 \text{ inH}_2\text{O}$ (2,49 mbar). With diaphragm in horizontal plane, zero shift of up to $5 \text{ inH}_2\text{O}$ (12,43 mbar) plus extension length on extended units. All zero shifts can be calibrated out. No span effect.
3051T/CA	Zero shifts up to $2.5 \text{ inH}_2\text{O}$ (6,22 mbar), which can be calibrated out. No span effect.

A.1.9 Vibration effect

Less than $\pm 0.1\%$ of URL when tested per the requirements of IEC60770-1 field or pipeline with high vibration level (10–60 Hz 0.21 mm displacement peak amplitude/ 60–2000 Hz 3g).

A.1.10 Power supply effect

Less than $\pm 0.005\%$ of calibrated span per volt.

A.1.11 Electromagnetic compatibility (EMC)

Meets all industrial environment requirements of EN61326. Maximum deviation $< 1\%$ Span during EMC disturbance⁽¹⁾.

A.1.12 Transient protection (option code T1)

Meets IEEE C62.41, Category Location B

6 kV crest (0.5 μs - 100 kHz)
3 kV crest (8×20 microseconds)
6 kV crest (1.2×50 microseconds)

1. During surge event device may exceed maximum EMC deviation limit or reset; however, device will self-recover and return to normal operation within specified start-up time.

A.2 Functional specifications

A.2.1 Range and sensor limits

Table A-1. Rosemount 3051CD, 3051CG, 3051L, and 3051H Range and Sensor Limits

Range	Minimum span	
	Rosemount 3051CD ⁽¹⁾ , CG, L, H	Upper (URL)
0	0.1 inH ₂ O (0,25 mbar)	3.0 inH ₂ O (7,47 mbar)
1	0.5 inH ₂ O (1,2 mbar)	25 inH ₂ O (62,3 mbar)
2	2.5 inH ₂ O (6,2 mbar)	250 inH ₂ O (0,62 bar)
3	10 inH ₂ O (24,9 mbar)	1000 inH ₂ O (2,49 bar)
4	3 psi (0,20 bar)	300 psi (20,6 bar)
5	20 psi (1,38 bar)	2000 psi (137,9 bar)

1. Range 0 only available with Rosemount 3051CD. Range 1 only available with Rosemount 3051CD or 3051CG.

Table A-2. Rosemount 3051CD, 3051CG, 3051L, and 3051H Range and Sensor Limits

Range	Lower (LRL)					
	Rosemount 3051C Differential	Rosemount 3051 Gage	Rosemount 3051L Differential	Rosemount 3051L Gage	Rosemount 3051H Differential	Rosemount 3051H Gage
0	-3.0 inH ₂ O (-7,47 mbar)	N/A	N/A	N/A	N/A	N/A
1	-25 inH ₂ O (-62,1 mbar)	-25 inH ₂ O (-62,1 mbar)	N/A	N/A	N/A	N/A
2	-250 inH ₂ O (-0,62 bar)	-250 inH ₂ O (-0,62 bar)	-250 inH ₂ O (-0,62 bar)	-250 inH ₂ O (-0,62 bar)	-250 inH ₂ O (-0,62 bar)	-250 inH ₂ O (-0,62 bar)
3	-1000 inH ₂ O (-2,49 bar)	0.5 psia (34,5 mbar abs)	-1000 inH ₂ O (-2,49 bar)	0.5 psia (34,5 mbar abs)	-1000 inH ₂ O (-2,49 bar)	0.5 psia (34,5 mbar abs)
4	-300 psi (-20,6 bar)	0.5 psia (34,5 mbar abs)	-300 psi (-20,6 bar)	0.5 psia (34,5 mbar abs)	-300 psi (-20,6 bar)	0.5 psia (34,5 mbar abs)
5	-2000 psi (-137,9 bar)	0.5 psia (34,5 mbar abs)	N/A	N/A	-2000 psi (-137,9 bar)	0.5 psia (34,5 mbar abs)

Table A-3. Range and Sensor Limits

Rosemount 3051CA				Rosemount 3051T				
Range	Minimum span	Range and sensor limits		Range	Minimum span	Range and sensor limits		Lower ⁽¹⁾ (LRL) (Gage)
		Upper (URL)	Lower (LRL)			Upper (URL)	Lower (LRL)	
1	0.3 psia (20,6 mbar)	30 psia (2,07 bar)	0 psia (0 bar)	1	0.3 psi (20,6 mbar)	30 psi (2,07 bar)	0 psia (0 bar)	-14.7 psig (-1,01 bar)
2	1.5 psia (0,103 bar)	150 psia (10,3 bar)	0 psia (0 bar)	2	1.5 psi (0,103 bar)	150 psi (10,3 bar)	0 psia (0 bar)	-14.7 psig (-1,01 bar)
3	8 psia (0,55 bar)	800 psia (55,2 bar)	0 psia (0 bar)	3	8 psi (0,55 bar)	800 psi (55,2 bar)	0 psia (0 bar)	-14.7 psig (-1,01 bar)
4	40 psia (2,76 bar)	4000 psia (275,8 bar)	0 psia (0 bar)	4	40 psi (2,76 bar)	4000 psi (275,8 bar)	0 psia (0 bar)	-14.7 psig (-1,01 bar)
				5	2000 psi (137,9 bar)	10000 psi (689,4 bar)	0 psia (0 bar)	-14.7 psig (-1,01 bar)

1. Assumes atmospheric pressure of 14.7 psig.

A.2.2 Zero and span adjustment requirements (HART and Low Power)

Zero and span values can be set anywhere within the range limits stated in Table A-1, Table A-2, and Table A-3.

Span must be greater than or equal to the minimum span stated in Table A-1, Table A-2, and Table A-3.

A.2.3 Service

Liquid, gas, and vapor applications

A.2.4 4–20 mA (output code A)

Output

Two-wire 4–20 mA, user-selectable for linear or square root output. Digital process variable superimposed on 4–20 mA signal, available to any host that conforms to the HART protocol.

Power supply

External power supply required. Standard transmitter (4–20 mA) operates on 10.5 to 55 Vdc with no load.

Load limitations

Maximum loop resistance is determined by the voltage level of the external power supply, as described by:

$$\text{Max. Loop Resistance} = 43.5 (\text{Power Supply Voltage} - 10.5)$$

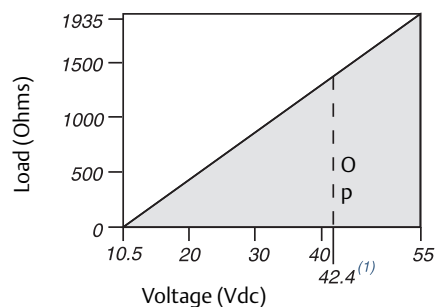

Communication requires a minimum loop resistance of 250 ohms.

1. For CSA approval, power supply must not exceed 42.4 V.

A.2.5 FOUNDATION Fieldbus (output code F) and PROFIBUS[®] (output code W)

Power supply

External power supply required; transmitters operate on 9.0–32.0 Vdc transmitter terminal voltage.

Current draw

17.5 mA for all configurations (including LCD display option)

A.2.6 FOUNDATION Fieldbus function block execution times

Block	Execution time
Resource	N/A
Transducer	N/A
LCD Block	N/A
Analog Input 1, 2	30 milliseconds
PID	45 milliseconds
Input selector	30 milliseconds
Arithmetic	35 milliseconds
Signal characterizer	40 milliseconds
Integrator	35 milliseconds

A.2.7 FOUNDATION Fieldbus parameters

Schedule Entries	7 (max.)
Links	20 (max.)
Virtual Communications Relationships (VCR)	12 (max.)

A.2.8 Standard function blocks

Resource block

Contains hardware, electronics, and diagnostic information.

Transducer block

Contains actual sensor measurement data including the sensor diagnostics and the ability to trim the pressure sensor or recall factory defaults.

LCD display block

Configures the local display.

Two analog input blocks

Processes the measurements for input into other function blocks. The output value is in engineering units or custom and contains a status indicating measurement quality.

PID block

Contains all logic to perform PID control in the field including cascade and feedforward.

A.2.9 Backup Link Active Scheduler (LAS)

The transmitter can function as a LAS if the current link master device fails or is removed from the segment.

A.2.10 Advanced control function block suite (option code A01)

Input selector block

Selects between inputs and generates an output using specific selection strategies such as minimum, maximum, midpoint, average or first “good.”

Arithmetic block

Provides pre-defined application-based equations including flow with partial density compensation, electronic remote seals, hydrostatic tank gauging, ratio control and others.

Signal characterizer block

Characterizes or approximates any function that defines an input/output relationship by configuring up to twenty X, Y coordinates. The block interpolates an output value for a given input value using the curve defined by the configured coordinates.

Integrator block

Compares the integrated or accumulated value from one or two variables to pre-trip and trip limits and generates discrete output signals when the limits are reached. This block is useful for calculating total flow, total mass, or volume over time.

A.2.11 FOUNDATION Fieldbus Diagnostics Suite (option code D01)

The Rosemount 3051C FOUNDATION Fieldbus Diagnostics provide Abnormal Situation Prevention (ASP) indication. The integral Statistical Process Monitoring (SPM) technology calculates the mean and standard deviation of the process variable 22 times per second. The Rosemount 3051C ASP algorithm uses these values and highly flexible configuration options for customization to many user-defined or application specific abnormal situations. The detection of plugged impulse lines is the first available predefined application.

A.2.12 Low Power (output code M)

Output

Three wire 1–5 Vdc or 0.8–3.2 Vdc (Option Code C2) user-selectable output. Also user selectable for linear or square root output configuration. Digital process variable superimposed on voltage signal, available to any host conforming to the HART protocol. Low-power transmitter operates on 6–14 Vdc with no load.

Power consumption

3.0 mA, 18–36 mW

Minimum load impedance

100 k Ω (V_{out} wiring)

Indication

Optional 5-digit LCD display

Overpressure Limits

Rosemount 3051CD/CG

- Range 0: 750 psi (51,7 bar)
- Range 1: 2000 psig (137,9 bar)
- Ranges 2–5: 3626 psig (250 bar)
4500 psig (310,3 bar) for option code P9

Rosemount 3051CA

- Range 1: 750 psia (51,7 bar)
- Range 2: 1500 psia (103,4 bar)
- Range 3: 1600 psia (110,3 bar)
- Range 4: 6000 psia (413,7 bar)

Rosemount 3051H

- All Ranges: 3626 psig (25 MPa)

Rosemount 3051TG/TA

- Range 1: 750 psi (51,7 bar)
- Range 2: 1500 psi (103,4 bar)
- Range 3: 1600 psi (110,3 bar)
- Range 4: 6000 psi (413,7 bar)
- Range 5: 15000 psi (1034,2 bar)

For Rosemount 3051L or level flange option codes FA, FB, FC, FD, FP, and FQ, limit is 0 psia to the flange rating or sensor rating, whichever is lower.

Table A-4. Rosemount 3051L and Level Flange Rating Limits

Standard	Type	CS rating	SST rating
ANSI/ASME	Class 150	285 psig	275 psig
ANSI/ASME	Class 300	740 psig	720 psig
ANSI/ASME	Class 600	1480 psig	1440 psig
At 100 °F (38 °C), the rating decreases with increasing temperature.			
DIN	PN 10–40	40 bar	40 bar
DIN	PN 10/16	16 bar	16 bar
DIN	PN 25/40	40 bar	40 bar
At 248 °F (120 °C), the rating decreases with increasing temperature.			

A.2.13 Static pressure limit

Rosemount 3051CD Only

Operates within specifications between static line pressures of 0.5 psia and 3626 psig (4500 psig (310, 3 bar) for Option Code P9).

Range 0: 0.5 psia and 750 psig (3, 4 bar and 51, 7 bar)

Range 1: 0.5 psia and 2000 psig (3, 4 bar and 137, 9 bar)

A.2.14 Burst pressure limits

Burst pressure on Coplanar, traditional, or 3051H process flange is 10000 psig (69 MPa).

Burst pressure for the 3051T is:

Ranges 1–4: 11000 psi (75,8 MPa)

Range 5: 26000 psig (179 MPa)

A.2.15 Failure mode alarm

Output code A

If self-diagnostics detect a gross transmitter failure, the analog signal will be driven either below 3.75 mA or to 21.75 mA to alert the user. NAMUR-compliant values are available, option code C4. High or low alarm signal is user-selectable by internal jumper.

Output code M

If self-diagnostics detect a gross transmitter failure, the analog signal will be driven either below 0.94 V or above 5.4 V to alert the user (below 0.75 V or above 4.4 V for Option C2). High or low alarm signal is user-selectable by internal jumper.

Output code F and W

If self-diagnostics detect a gross transmitter failure, that information gets passed as a status along with the process variable.

A.2.16 Temperature limits

Ambient

–40 to 185 °F (–40 to 85 °C)

With LCD display⁽¹⁾: –40 to 175 °F (–40 to 80 °C)

Storage

–50 to 230 °F (–46 to 110 °C)

With LCD display: –40 to 185 °F (–40 to 85 °C)

Process

At atmospheric pressures and above. See Table A-5

Table A-5. Rosemount 3051 Process Temperature Limits

Rosemount 3051CD, 3051CG, 3051CA	
Silicone fill sensor ⁽¹⁾	N/A
with coplanar flange ⁽²⁾	–40 to 250 °F (–40 to 121 °C)
with traditional flange ⁽²⁾⁽³⁾	–40 to 300 °F (–40 to 149 °C)
with Level Flange ⁽²⁾	–40 to 300 °F (–40 to 149 °C)
with Rosemount 305 Integral Manifold ⁽²⁾	–40 to 300 °F (–40 to 149 °C)
Inert Fill Sensor ⁽¹⁾⁽⁴⁾⁽⁵⁾	–40 to 185 °F (–40 to 85 °C)
Rosemount 3051H (process fill fluid)⁽¹⁾	
Silicone 200	–40 to 375 °F (–40 to 191 °C)
Inert	–50 to 350 °F (–45 to 177 °C)
Neobee M-20 [®]	0 to 375 °F (–18 to 191 °C)
Rosemount 3051T (process fill fluid)⁽¹⁾⁽²⁾	
Silicone fill sensor	–40 to 250 °F (–40 to 121 °C)
Inert fill sensor	–22 to 250 °F (–30 to 121 °C)
Rosemount 3051L low-side temperature limits⁽¹⁾⁽²⁾	
Silicone fill sensor	–40 to 250 °F (–40 to 121 °C)
Inert fill sensor	0 to 185 °F (–18 to 85 °C)
Rosemount 3051L high-side temperature limits (process fill fluid)	
Syltherm [®] XLT	–100 to 300 °F (–73 to 149 °C)
D.C. [®] Silicone 704	32 to 400 °F (0 to 205 °C)
Silicone 200	–40 to 400 °F (–40 to 205 °C)
Inert	–50 to 350 °F (–45 to 177 °C)
Glycerin and Water	0 to 200 °F (–18 to 93 °C)
Neobee M-20	0 to 400 °F (–18 to 205 °C)
Propylene Glycol and Water	0 to 200 °F (–18 to 93 °C)

1. Process temperatures above 185 °F (85 °C) require derating the ambient limits by a 1.5:1 ratio (0.6:1 ratio for the Rosemount 3051H).
2. 220 °F (104 °C) limit in vacuum service; 130 °F (54 °C) for pressures below 0.5 psia.
3. 3051CD0 process temperature limits are –40 to 212 °F (–45 to 100 °C)
4. 160 °F (71 °C) limit in vacuum service.
5. Not available for Rosemount 3051CA.

Humidity limits

0–100 percent volumetric displacement

1. LCD display may not be readable and LCD updates will be slower at temperatures below –4 °F (–20 °C).

Less than 0.005 in³ (0,08 cm³)

Damping

Analog output response to a step input change is user-selectable from zero to 36 seconds for one time constant. This software damping is in addition to sensor module response time.

A.3 Physical specifications

A.3.1 Electrical connections

1/2–14 NPT, G1/2, and M20 × 1.5 (CM20) conduit. HART interface connections fixed to terminal block.

A.3.2 Process connections

All Models except Rosemount 3051L and 3051T

1/4–18 NPT on 2 1/8-in. centers

1/2–14 NPT on 2-, 2 1/8-, or 2 1/4-in. centers

Rosemount 3051L

High pressure side: 2-, 3-, or 4-in., ASME B 16.5 (ANSI) Class 150, 300 or 600 flange; 50, 80 or 100 mm, PN 40 or 10/16 flange

Low pressure side: 1/4–18 NPT on flange 1/2–14 NPT on adapter

Rosemount 3051T

1/2–14 NPT female. A DIN 16288 male (available in SST for Range 1–4 transmitters only), or autoclave type F-250-C (Pressure relieved 9/16–18 gland thread; 1/4 OD high pressure tube 60 degrees cone; available in SST for range 5 transmitters only).

A.3.3 Process-wetted parts

Drain/vent valves

316 SST, Alloy C-276, or Alloy 400/K-500⁽¹⁾ material (Drain vent seat: Alloy 400, Drain vent stem: Alloy K-500)

1. Alloy 400/K-500 is not available with Rosemount 3051L or 3051H.

Process flanges and adapters

Plated carbon steel

SST: CF-8M (Cast 316 SST) per ASTM A743
Cast C-276: CW-12MW per ASTM A494
Cast Alloy 400: M-30C per ASTM A494

Wetted O-rings

Glass-filled PTFE or Graphite-filled PTFE

Process isolating diaphragms

Isolating diaphragm material	3051CD/CG	3051T	3051CA	3051H
316L SST	•	•	•	•
Alloy C-276	•	•	•	•
Alloy 400	•	N/A	•	N/A
Tantalum	•	N/A	N/A	•
Gold-plated Alloy 400	•	N/A	•	N/A
Gold-plated SST	•	N/A	•	N/A

A.3.4 Rosemount 3051L process wetted parts

Flanged process connection (transmitter high side)

Process diaphragms, including process gasket surface

- 316L SST, Alloy C-276, or Tantalum
- Extension
- CF-3M (Cast version of 316L SST, material per ASTM-A743), or Alloy C-276. Fits schedule 40 and 80 pipe.
- Mounting flange
- Zinc-cobalt plated CS or SST

Reference process connection (transmitter low side)

Isolating diaphragms

316L SST or Alloy C-276

Reference flange and adapter

CF-8M (Cast version of 316 SST, material per ASTM-A743)

A.3.5 Non-wetted parts

Electronics housing

Low copper aluminum or SST: CF-3M or CF-8M (Cast version of 316L or 316 SST, material per ASTM-A743). NEMA 4X, IP 65, IP 66

Coplanar sensor module housing

CF-3M (Cast version of 316L SST, material per ASTM-A743)

Bolts

ASTM A449, Type 1 (zinc-cobalt plated carbon steel)
ASTM F593G, Condition CW1 (Austenitic 316 SST)
ASTM A193, Grade B7M (zinc plated alloy steel)
Alloy 400

Sensor module fill fluid

Silicone oil (Silicone 200) or Fluorocarbon oil (Halocarbon or Fluorinert® FC-43 for 3051T)

Process fill fluid (Rosemount 3051L and 3051H only)

Rosemount 3051L: Syltherm XLT, D.C. Silicone 704, Silicone 200, inert, glycerin and water, Neobee M-20 or propylene glycol and water

Rosemount 3051H: inert, Neobee M-20, or Silicone 200

Paint

Polyurethane

Cover O-rings

Buna-N

A.3.6 Shipping weights

Refer to “Shipping weights” on page 132.

A.4 Dimensional drawings

Figure A-1. Rosemount 3051 Exploded View

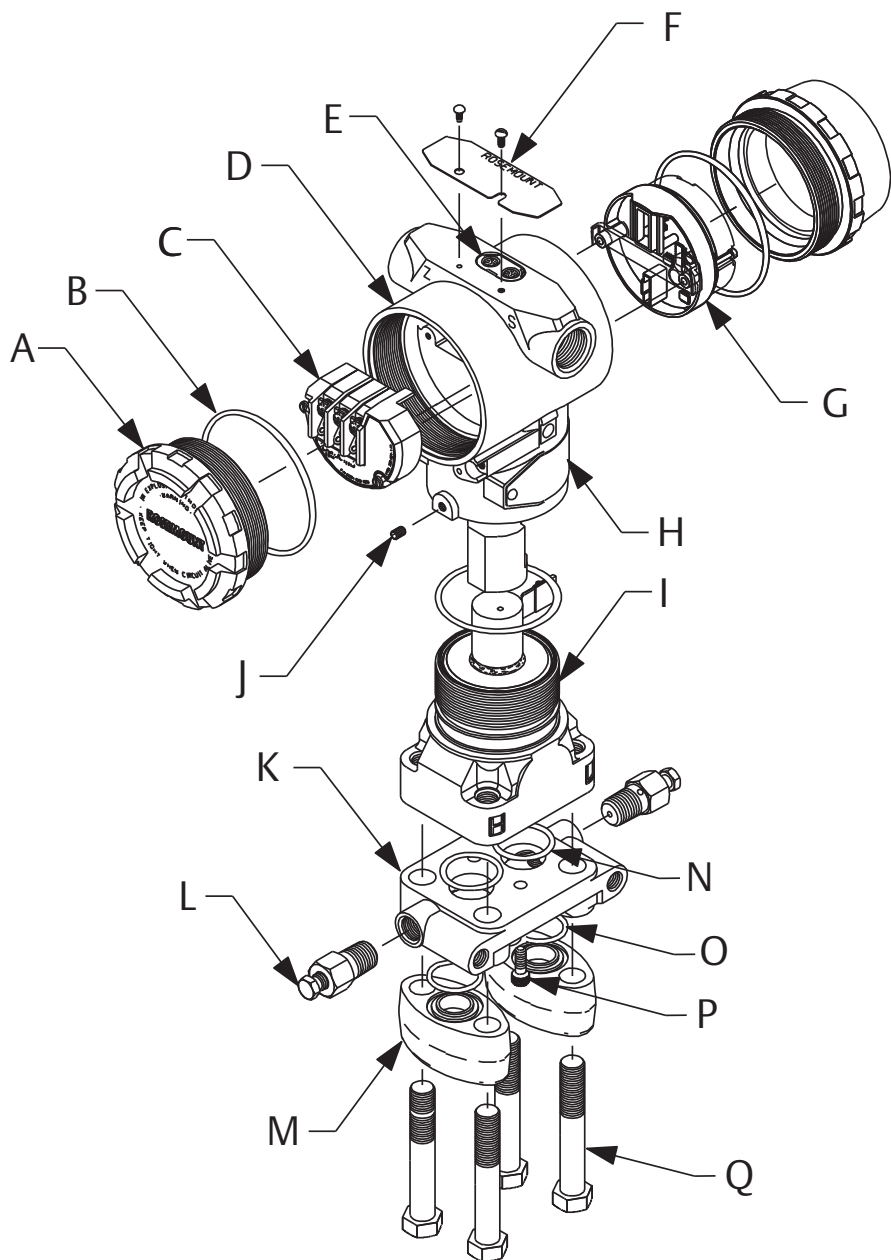

- A. Cover
- B. Cover O-ring
- C. Terminal block
- D. Electronic housing
- E. Span and zero adjustments⁽¹⁾
- F. Certification label
- G. Electronics board
- H. Nameplate
- I. Sensor module

- J. Housing rotation set screw (180° maximum housing rotation without further disassembly)
- K. Coplanar flange
- L. Drain/vent valve
- M. Flange adapters
- N. Process O-ring
- O. Flange adapter O-ring
- P. Flange alignment screw (not pressure retaining)
- Q. Flange bolts

1. Span and Zero Adjustments are not available with Fieldbus or PROFIBUS Protocols.

Figure A-2. Rosemount 3051C Coplanar Flange

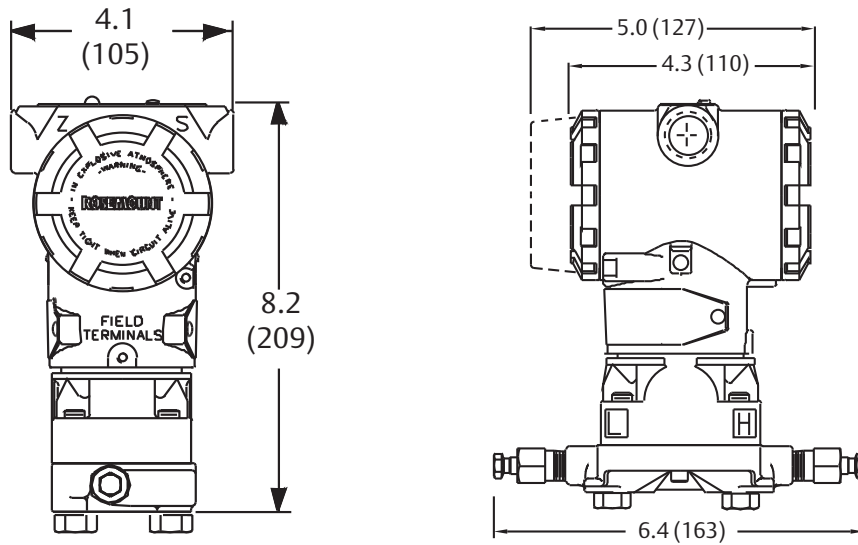

Dimensions are in inches (millimeters).

Figure A-3. Rosemount 3051C Coplanar Flange with Rosemount 305 Coplanar Manifold

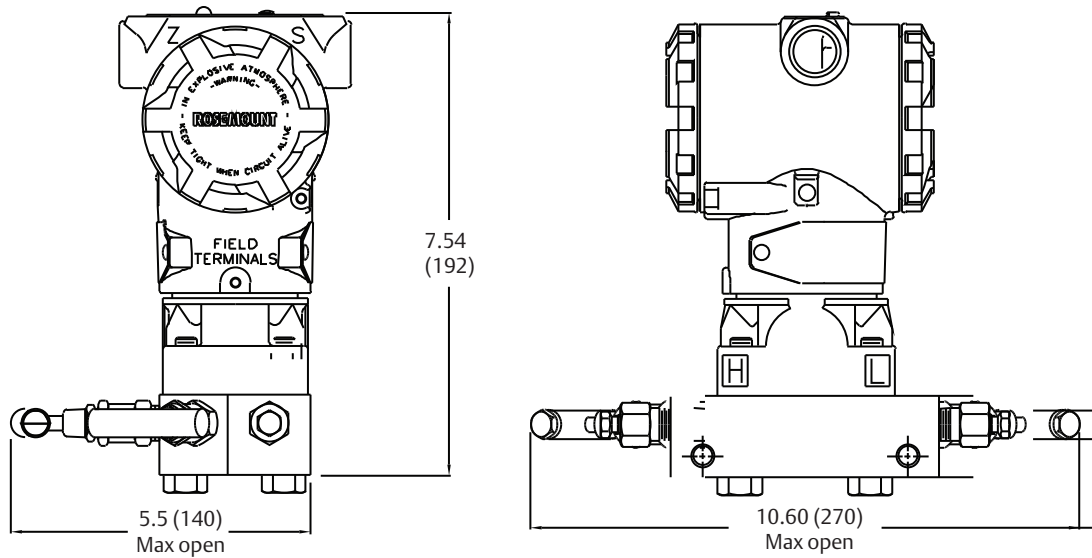

Dimensions are in inches (millimeters).

Figure A-4. Coplanar Flange Mounting Configurations with Optional Bracket (B4) for 2-in. Pipe or Panel Mounting

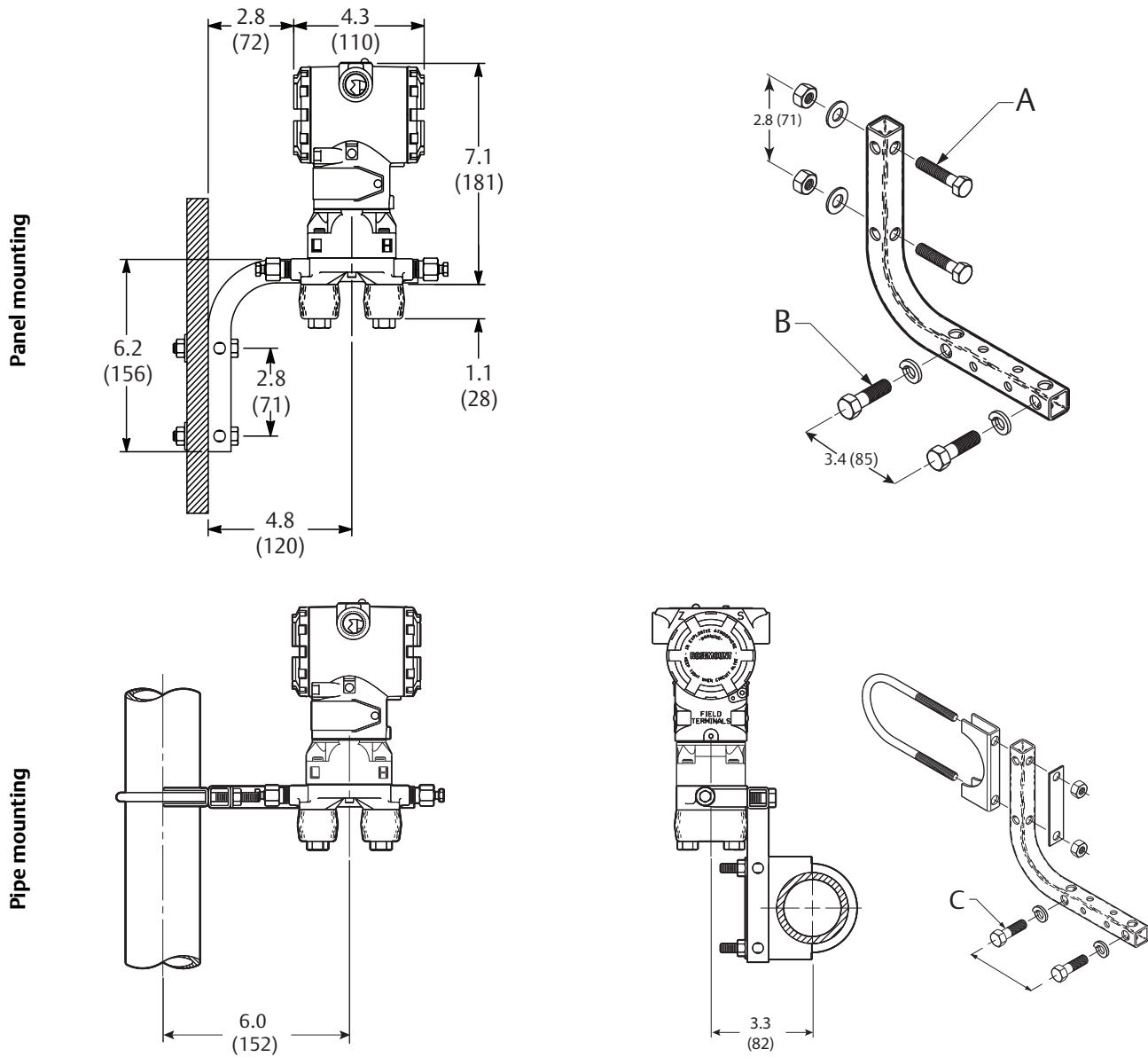

- A. $\frac{5}{16} \times 1\frac{1}{2}$ bolts for panel mounting (not supplied)
 - B. $\frac{3}{8}-16 \times 1\frac{1}{4}$ bolts for mounting to transmitter
 - C. 2-in U-bolt for pipe mounting
- Dimensions are in inches (millimeters).

Figure A-5. Rosemount 3051C Coplanar with Traditional Flange

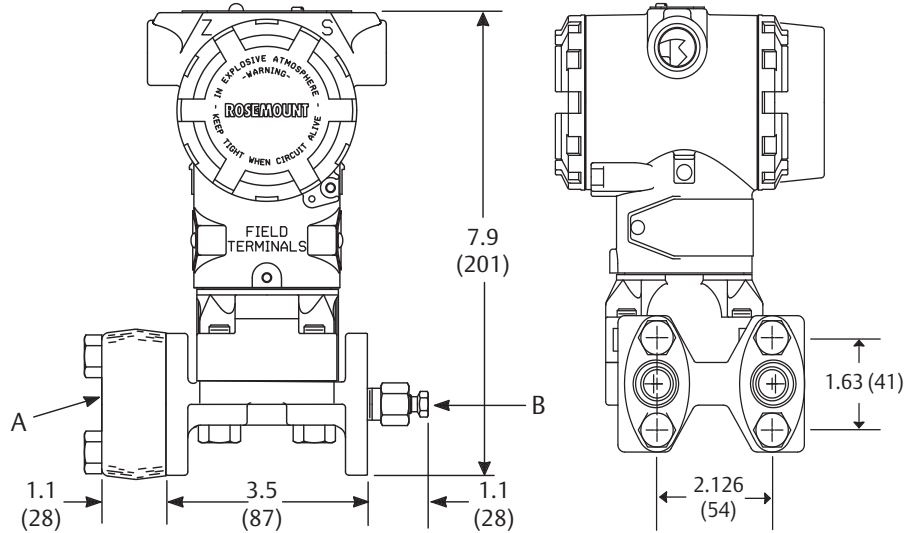

A. 1/2-14 NPT flange adapter (optional)
B. Drain/vent valve
Dimensions are in inches (millimeters).

Figure A-6. Rosemount 3051C Coplanar with Rosemount 305 Traditional Integral Manifold

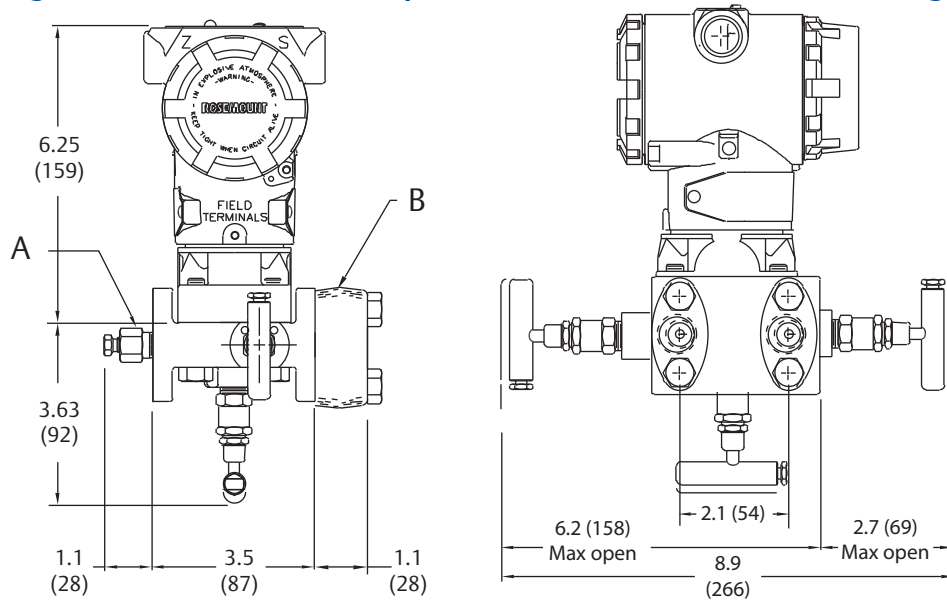

Dimensions are in inches (millimeters).

Figure A-7. Traditional Flange Mounting Configurations with Optional Brackets for 2-in. Pipe or Panel Mounting

Panel mounting bracket (option B2/B8)

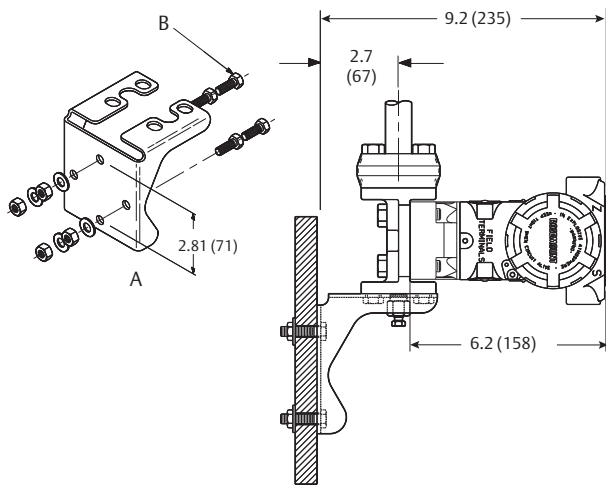

2-in. pipe mounting bracket (option B1/B7/BA)

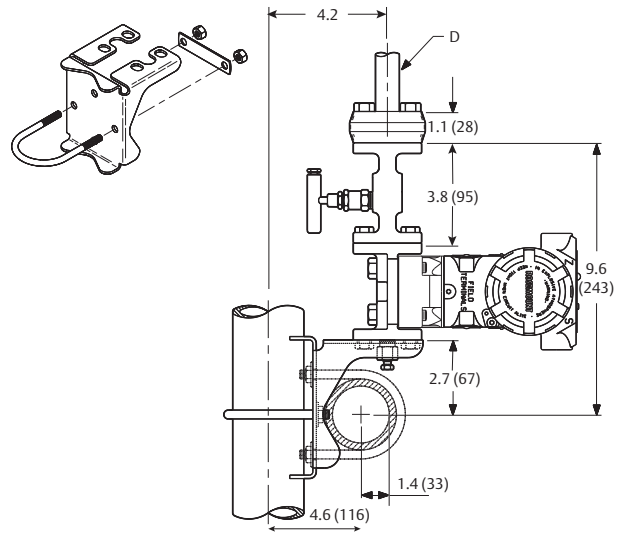

2-in. pipe mounting bracket (option B3/B9/BC)

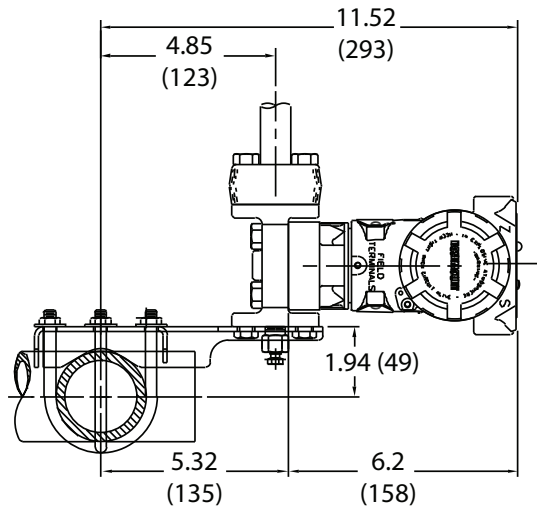

A. Panel mounting bracket
 B. $\frac{5}{16} \times \frac{7}{8}$ bolts for panel mounting (not supplied)
 Dimensions are in inches (millimeters).

C. Pipe mounting bracket
 D. Impulse piping

Figure A-8. Rosemount 3051T

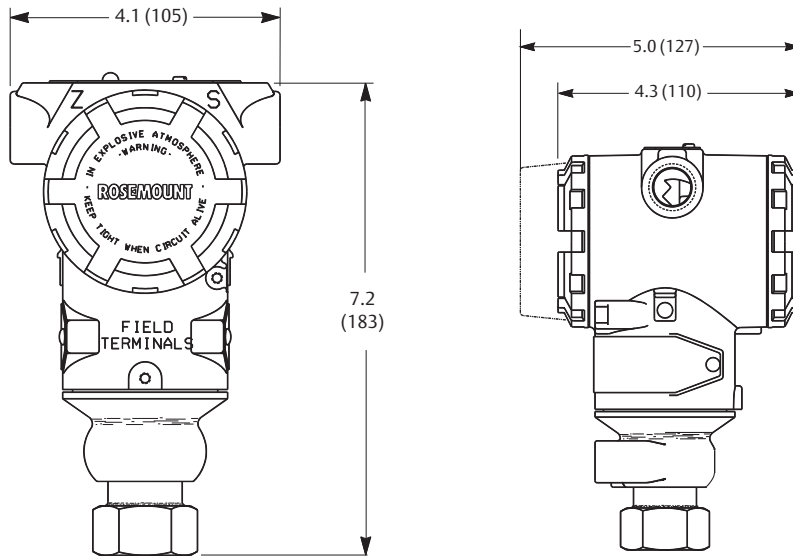

Dimensions are in inches (millimeters).

Figure A-9. Rosemount 3051T with Rosemount 306 Integral Manifold

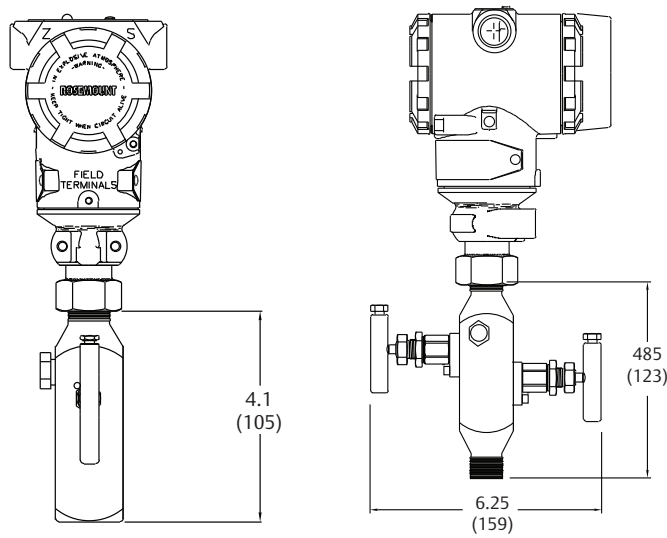

Dimensions are in inches (millimeters).

Figure A-10. Rosemount 3051T Typical Mounting Configurations with Optional Mounting Bracket

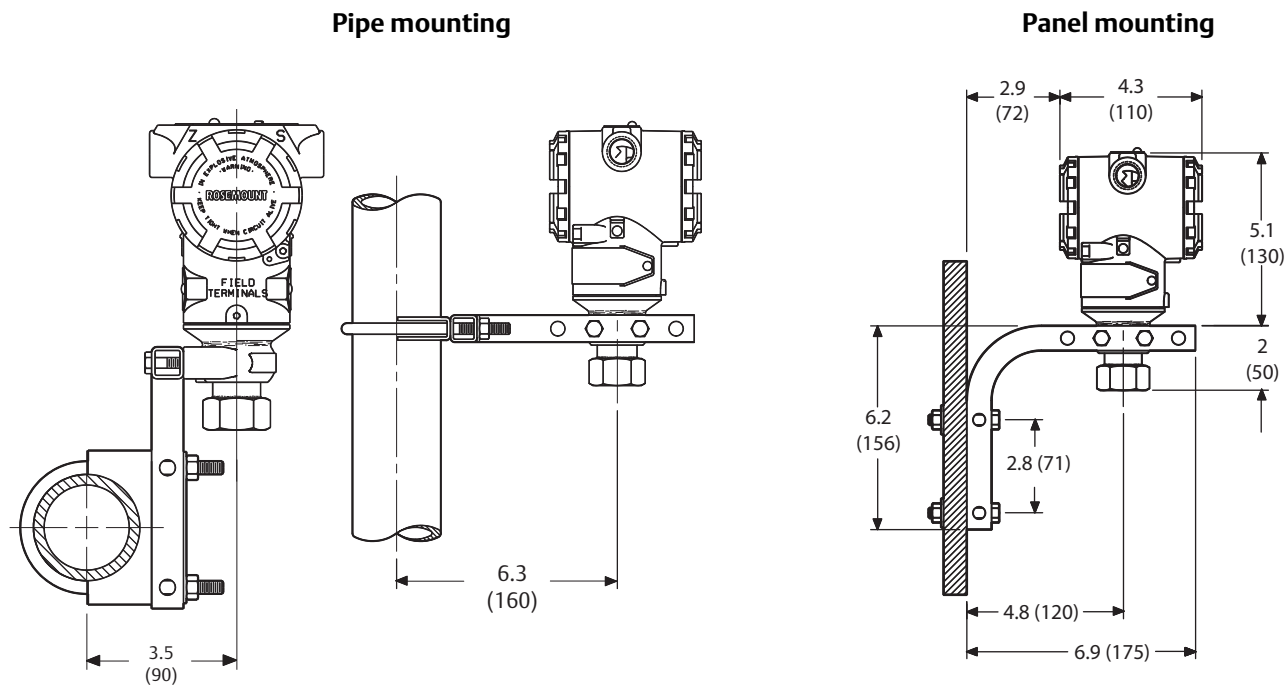

Dimensions are in inches (millimeters).

Figure A-11. Rosemount 3051L

2-in. flange configuring (flush mount only)

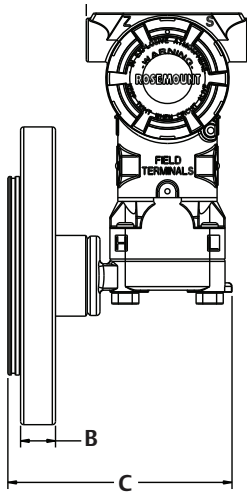

3- and 4-in. flange configuration

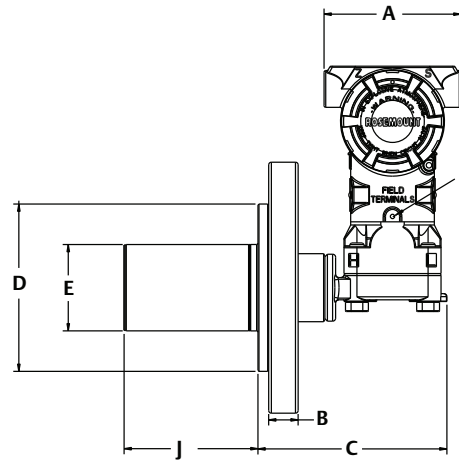

Optional flushing connection ring (lower housing)

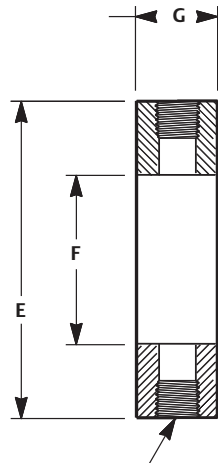

Diaphragm assembly and mounting flange

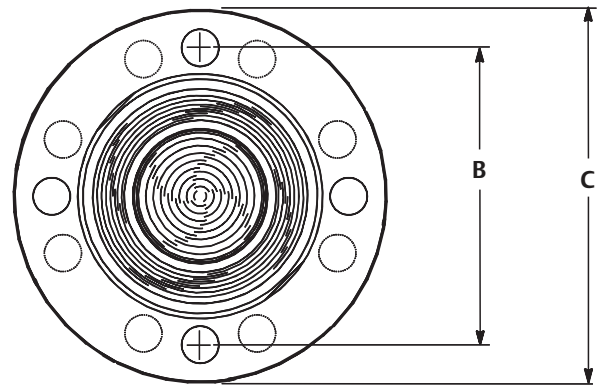

For A to H, refer to Table A-6.
I. Housing rotation set screw
Dimensions are in inches (millimeters).

J. Extension 2, 4, or 6 (51, 102, or 152)
K. Flushing connection

Figure A-12. Diaphragm Assembly and Mounting Flange

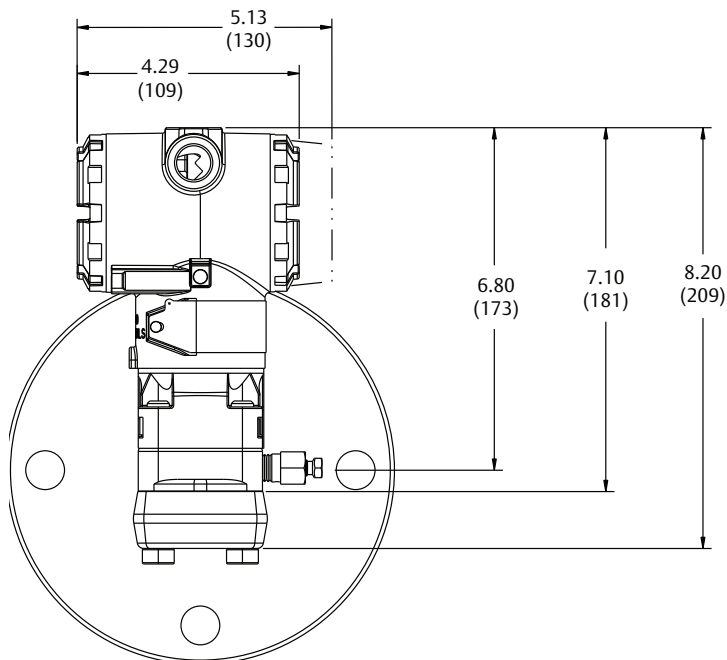

Dimensions are in inches (millimeters).

Table A-6. Rosemount 3051L Dimensional Specifications

Class ⁽¹⁾	Pipe size	Flange thickness A	Bolt circle diameter B	Outside diameter C	No. of bolts	Bolt hole diameter	Extension diameter ⁽¹⁾ D	O.D. gasket surface E
ASME B16.5 (ANSI) 150	2 (51)	0.69 (18)	4.75 (121)	6.0 (152)	4	0.75 (19)	N/A	3.6 (92)
	3 (76)	0.88 (22)	6.0 (152)	7.5 (191)	4	0.75 (19)	2.58 (66)	5.0 (127)
	4 (102)	0.88 (22)	7.5 (191)	9.0 (229)	8	0.75 (19)	3.5 (89)	6.2 (158)
ASME B16.5 (ANSI) 300	2 (51)	0.82 (21)	5.0 (127)	6.5 (165)	8	0.75 (19)	NA	3.6 (92)
	3 (76)	1.06 (27)	6.62 (168)	8.25 (210)	8	0.88 (22)	2.58 (66)	5.0 (127)
	4 (102)	1.19 (30)	7.88 (200)	10.0 (254)	8	0.88 (22)	3.5 (89)	6.2 (158)
ASME B16.5 (ANSI) 600	2 (51)	1.00 (25)	5.0 (127)	6.5 (165)	8	0.75 (19)	N/A	3.6 (92)
	3 (76)	1.25 (32)	6.62 (168)	8.25 (210)	8	0.88 (22)	2.58 (66)	5.0 (127)
DIN 2501 PN 10-40	DN 50	20 mm	125 mm	165 mm	4	18 mm	NA	4.0 (102)
DIN 2501 PN 25/40	DN 80	24 mm	160 mm	200 mm	8	18 mm	66 mm	5.4 (138)
	DN 100	24 mm	190 mm	235 mm	8	22 mm	89 mm	6.2 (158)
DIN 2501 PN 10/16	DN 100	20 mm	180 mm	220 mm	8	18 mm	89 mm	6.2 (158)

1. Tolerances are 0.040 (1.02), -0.020 (0.51).

Class ⁽¹⁾	Pipe size	Process side F	Lower housing G		H
			1/4 NPT	1/2 NPT	
ASME B16.5 (ANSI) 150	2 (51)	2.12 (54)	0.97 (25)	1.31 (33)	5.65 (143)
	3 (76)	3.6 (91)	0.97 (25)	1.31 (33)	5.65 (143)
	4 (102)	3.6 (91)	0.97 (25)	1.31 (33)	5.65 (143)
ASME B16.5 (ANSI) 300	2 (51)	2.12 (54)	0.97 (25)	1.31 (33)	5.65 (143)
	3 (76)	3.6 (91)	0.97 (25)	1.31 (33)	5.65 (143)
	4 (102)	3.6 (91)	0.97 (25)	1.31 (33)	5.65 (143)
ASME B16.5 (ANSI) 600	2 (51)	2.12 (54)	0.97 (25)	1.31 (33)	7.65 (194)
	3 (76)	3.6 (91)	0.97 (25)	1.31 (33)	7.65 (194)
DIN 2501 PN 10-40	DN 50	2.4 (61)	0.97 (25)	1.31 (33)	5.65 (143)
DIN 2501 PN 25/40	DN 80	3.6 (91)	0.97 (25)	1.31 (33)	5.65 (143)
	DN 100	3.6 (91)	0.97 (25)	1.31 (33)	5.65 (143)
DIN 2501 PN 10/16	DN 100	3.6 (91)	0.97 (25)	1.31 (33)	5.65 (143)

1. Tolerances are 0.040 (1,02), -0.020 (0,51).

Figure A-13. Rosemount 3051H Pressure Transmitter Exploded View

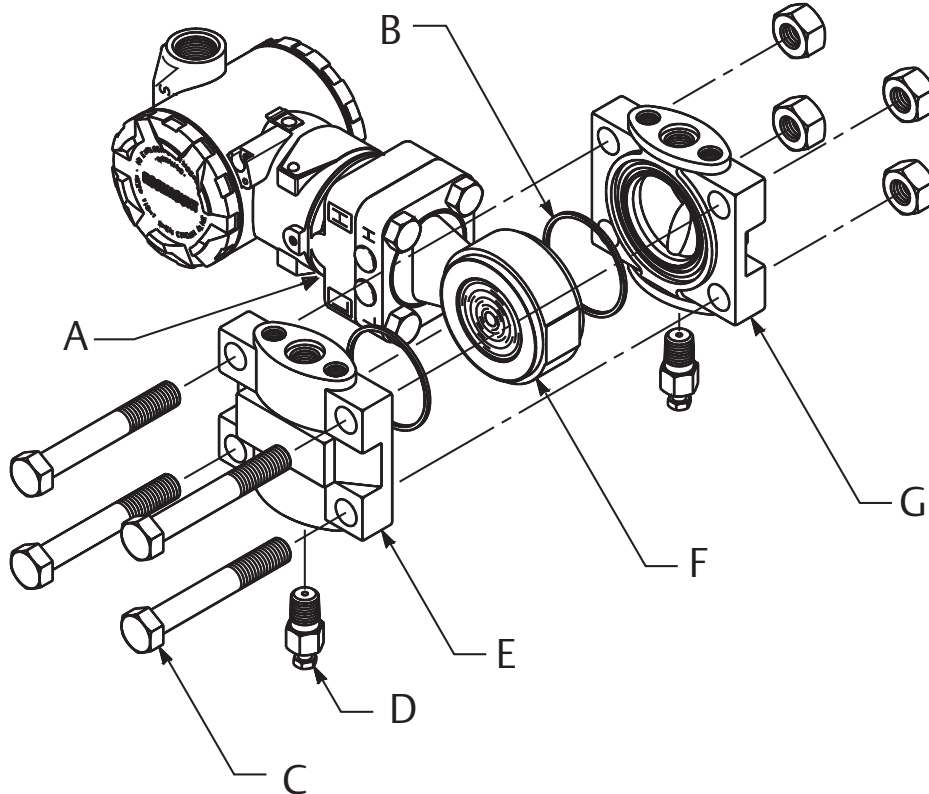

A. Sensor module
B. secondary filled system
C. Flange bolts
D. Drain/vent valve

E. Low side process flange
F. Process isolating diagram
G. High side process flange

Figure A-14. Rosemount 3051H Pressure Transmitter

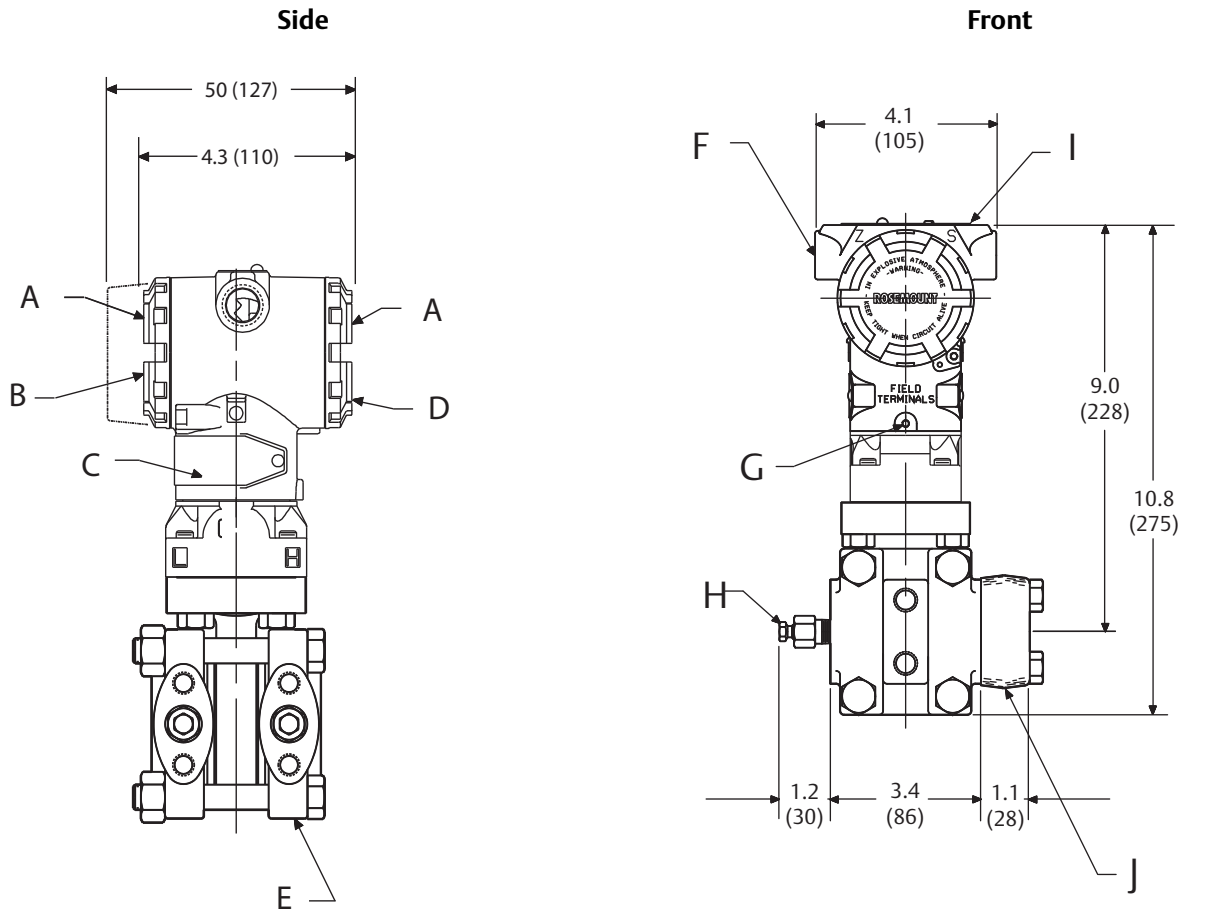

- A. 0.75 (19) clearance for cover removal
 - B. Transmitter circuitry
 - C. Nameplate
 - D. Terminal connections
 - E. 1/2-18 NPT on process flange for pressure connection without the use of mounting adapters
 - F. 1/2-14 NPT conduit connection (two places, other sizes available)
 - G. Housing rotation set screw
 - H. Drain/vent valve
 - I. Certification label
 - J. 1/2-14 NPT on Optional Mounting Adapters⁽¹⁾
- Dimensions are in inches (millimeters).

1. Adapters can be rotated to give adapter connection centers of 2.00 (51), 2.126 (54), or 2.25 (57).

Figure A-15. Rosemount 3051H Mounting Brackets for 2-in. Pipe and Panel Mount (Option Code B5/B6)

Pipe mounting configuration

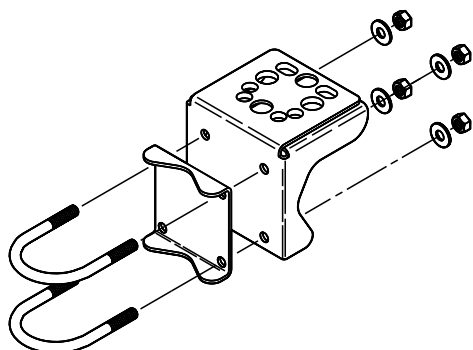

Panel mounting configuration⁽¹⁾

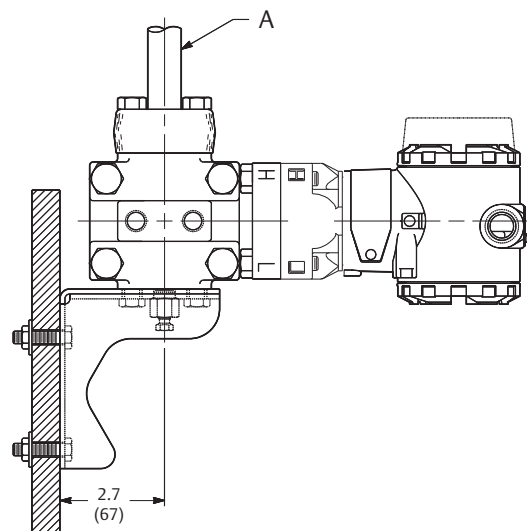
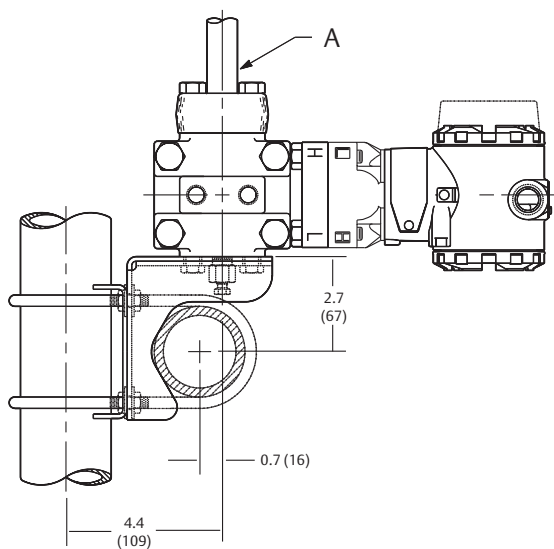
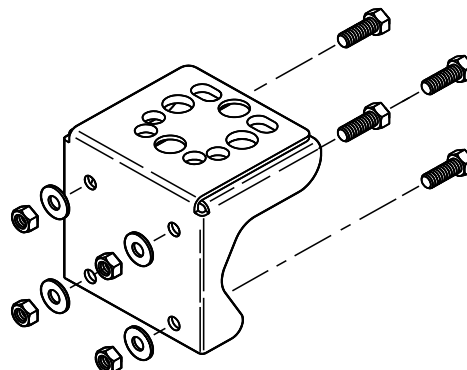

A. Impulse piping
Dimension are in inches (millimeters).

1. $\frac{7}{16} - 20 \times \frac{3}{4}$ bolts supplied for attaching bracket to transmitter.

A.5 Ordering information

Table A-7. Rosemount 3051C Coplanar Pressure Transmitter Ordering Information

The starred offerings (★) represent the most common options and should be selected for best delivery. The non-starred offerings are subject to additional delivery lead time.

Model	Transmitter type			
3051C	Coplanar pressure transmitter			
Measurement Type				
D	Differential			★
G	Gage			★
A	Absolute			
Pressure ranges (range/min. span)				
	Rosemount 3051CD	Rosemount 3051CG ⁽¹⁾	Rosemount 3051CA	
1	-25 to 25 inH ₂ O/0.5 inH ₂ O (-62,2 to 62,2 mbar/1,2 mbar)	-25 to 25 inH ₂ O/0.5 inH ₂ O (-62,1 to 62,2 mbar/1,2 mbar)	0 to 30 psia/0.3 psia (0 to 2,1 bar/20,7 mbar)	★
2	-250 to 250 inH ₂ O/2.5 inH ₂ O (-623 to 623 mbar/6,2 mbar)	-250 to 250 inH ₂ O/2.5 inH ₂ O (-621 to 623 mbar/6,2 mbar)	0 to 150 psia/1.5 psia (0 to 10,3 bar/0,1 bar)	★
3	-1000 to 1000 inH ₂ O/10 inH ₂ O (-2,5 to 2,5 bar/25 mbar)	-393 to 1000 inH ₂ O/10 in H ₂ O (-0,98 to 2,5 bar/25 mbar)	0 to 800 psia/8 psia (0 to 55,2 bar/0,55 bar)	★
4	-300 to 300 psi/3 psi (-20,7 to 20,7 bar/0,2 bar)	-14.2 to 300 psi/3 psi (-0,98 to 20,7 bar/0,2 bar)	0 to 4000 psia/40 psia (0 to 275,8 bar/2,8 bar)	★
5	-2000 to 2000 psi/20 psi (-137,9 to 137,9 bar/1,4 bar)	-14.2 to 2000 psig/20 psi (-0,98 to 137,9 bar/1,4 bar)	N/A	★
0 ⁽²⁾	-3 to 3 inH ₂ O/0.1 inH ₂ O (-7,5 to 7,5 mbar/0,25 mbar)	N/A	N/A	
Output				
A	4–20 mA with digital signal based on HART Protocol			★
F	FOUNDATION Fieldbus Protocol			★
W ⁽³⁾	PROFIBUS PA Protocol			★
M ⁽⁴⁾	Low-Power, 1–5 Vdc with Digital Signal Based on HART Protocol (See Option C2 for 0.8–3.2 V dc)			
Materials of construction				
	Process flange type	Flange material	Drain/vent	
2	Coplanar	SST	SST	★
3 ⁽⁵⁾	Coplanar	Cast C-276	Alloy C-276	★
4	Coplanar	Cast Alloy 400	Alloy 400/K-500	★
5	Coplanar	Plated CS	SST	★
7 ⁽⁵⁾	Coplanar	SST	Alloy C-276	★
8 ⁽⁵⁾	Coplanar	Plated CS	Alloy C-276	★
0	Alternate flange—see options on page 130			★

Table A-7. Rosemount 3051C Coplanar Pressure Transmitter Ordering Information

The starred offerings (★) represent the most common options and should be selected for best delivery. The non-starred offerings are subject to additional delivery lead time.

Isolating diaphragm			
2 ⁽⁵⁾	316L SST		★
3 ⁽⁵⁾	Alloy C-276		★
4	Alloy 400		
5 ⁽⁶⁾	Tantalum ()		
6	Gold-plated Alloy 400 (Use in combination with O-ring Option Code B.)		
7	Gold-plated SST		
O-ring			
A	Glass-filled PTFE		★
B	Graphite-filled PTFE		★
Sensor fill fluid			
1	Silicone		★
2	Inert fill (differential and gage only)		★
	Housing material	Conduit entry size	
A	Polyurethane-covered aluminum	1/2-14 NPT	★
B	Polyurethane-covered aluminum	M20 × 1.5 (CM20)	★
J	SST	1/2-14 NPT	★
K	SST	M20 × 1.5 (CM20)	★
D	Polyurethane-covered aluminum	G1/2	
M	SST	G1/2	

Options (Include with selected model number)

Plantweb™ control functionality			
A01	FOUNDATION Fieldbus Advanced Control Function Block Suite		★
Plantweb diagnostic functionality			
D01	FOUNDATION Fieldbus Diagnostics Suite		★
Alternate Flange			
H2	Traditional flange, 316 SST, SST drain/vent		★
H3 ⁽⁵⁾	Traditional Flange, Alloy C, Alloy C-276 drain/vent		★
H4	Traditional Flange, Monel, Monel drain/vent		★
H7 ⁽⁵⁾	Traditional Flange, 316 SST, Alloy C-276 drain/vent		★
HJ	DIN Compliant Traditional Flange, SST, 1/16 in. adapter/manifold bolting		★
FA	Level Flange, SST, 2 in., ANSI Class 150, vertical mount		★
FB	Level Flange, SST, 2 in., ANSI Class 300, vertical mount		★

Table A-7. Rosemount 3051C Coplanar Pressure Transmitter Ordering Information

The starred offerings (★) represent the most common options and should be selected for best delivery. The non-starred offerings are subject to additional delivery lead time.

FC	Level Flange, SST, 3 in., ANSI Class 150, vertical mount	★
FD	Level Flange, SST, 3 in., ANSI Class 300, vertical mount	★
FP	DIN Level Flange, SST, DN 50, PN 40, vertical mount	★
FQ	DIN Level Flange, SST, DN 80, PN 40, vertical mount	★
HK	DIN Compliant Traditional Flange, SST, 10 mm adapter/manifold bolting	
HL ⁽⁷⁾	DIN Compliant Traditional Flange, SST, 12 mm adapter/manifold bolting	
Integral assembly⁽⁸⁾		
S3	Assemble to Rosemount 405 Compact Orifice Plate	★
S5	Assemble to Rosemount 305 Integral Manifold (specified separately, see the Rosemount Manifolds Product Data Sheet)	★
S6	Assemble to Rosemount 304 Manifold or Connection System	★
Integral mount primary element^{(8) (9)}		
S4	Assemble to Rosemount Annubar or Rosemount 1195 Integral Orifice ()	★
Seal assemblies⁽⁸⁾		
S1	Assemble to one Rosemount 1199 seal	★
S2	Assemble to two Rosemount 1199 seals	★
All-welded seal assemblies (for high vacuum applications)⁽⁸⁾		
S0	One seal, all-welded system (direct mount connection type)	★
S7	One seal, all-welded system (capillary connection type)	★
S8	Two seals, all-welded system (capillary connection type)	★
S9	Two seals, all-welded system (one direct mount and one capillary connection type)	★
Mounting bracket		
B1	Traditional flange bracket for 2-in. pipe mounting, CS bolts	★
B2	Traditional flange bracket for panel mounting, CS bolts	★
B3	Traditional flange flat bracket for 2-in. pipe mounting, CS bolts	★
B4	Coplanar flange bracket for 2-in. pipe or panel mounting, all SST	★
B7	B1 bracket with Series 300 SST bolts	★
B8	B2 bracket with Series 300 SST bolts	★
B9	B3 bracket with Series 300 SST bolts	★
BA	SST B1 bracket with Series 300 SST bolts	★
BC	SST B3 bracket with Series 300 SST bolts	★

Table A-7. Rosemount 3051C Coplanar Pressure Transmitter Ordering Information

The starred offerings (★) represent the most common options and should be selected for best delivery. The non-starred offerings are subject to additional delivery lead time.

Product certifications		
C6	CSA Explosion-proof, Dust Ignition-proof, Intrinsically Safe, and Division 2	★
E2	INMETRO Flameproof	★
E3	China Flameproof	★
E4 ⁽¹⁰⁾	TIIS Flame-proof	★
E5	FM Explosion-proof, Dust Ignition-Proof	★
E7 ⁽¹¹⁾	IECEx Flameproof, Dust Ignition-proof	★
E8	ATEX Flameproof and Dust	★
I1 ⁽¹¹⁾	ATEX Intrinsic Safety and Dust	★
I2	INMETRO Intrinsic Safety	★
I3	China Intrinsic Safety	★
I4	TIIS Intrinsic Safety	★
I5	FM Intrinsically Safe, Division 2	★
I7 ⁽¹¹⁾	IECEx Intrinsic Safety	★
IA	ATEX FISCO Intrinsic Safety; for FOUNDATION Fieldbus protocol only	★
IE	FM FISCO Intrinsically Safe; for FOUNDATION ieldbus protocol only	★
K2	INMETRO Flameproof, Instrinsic Safety	★
K5	FM Explosion-proof, Dust Ignition-Proof, Intrinsically Safe, and Division 2	★
K6 ⁽¹¹⁾	CSA and ATEX Explosion-proof, Intrinsically Safe, and Division 2 (combination of C6 and K8)	★
K7 ⁽¹¹⁾	IECEx Flame-proof, Dust Ignition-proof, Intrinsic Safety, and Type n (combination of I7, N7, and E7)	★
K8 ⁽¹¹⁾	ATEX Flameproof, Intrinsic Safety, Type n, Dust (combination of E8, I1, and N1)	★
KB	FM and CSA Explosion-proof, Dust Ignition Proof, Intrinsically Safe, and Division 2 (combination of K5 and C6)	★
KD ⁽¹⁰⁾	FM, CSA, and ATEX Explosion-proof, Intrinsically Safe (combination of K5, C6, I1, and E8)	★
N1 ⁽¹⁰⁾	ATEX Type n and Dust	★
N3	China Type n	★
N7 ⁽¹¹⁾	IECEx Type n	★
Custody transfer ⁽¹⁵⁾⁽¹²⁾		
C5	Measurement Canada accuracy approval	★
Bolting material		
L4	Austenitic 316 SST bolts	★
L5	ASTM A 193, Grade B7M bolts	★
L6	Alloy K-500 bolts	★

Table A-7. Rosemount 3051C Coplanar Pressure Transmitter Ordering Information

The starred offerings (★) represent the most common options and should be selected for best delivery. The non-starred offerings are subject to additional delivery lead time.

Display type		
M4 ⁽¹³⁾	LCD display with Local Operator Interface	★
M5	LCD display for aluminum housing (housing codes A, B, C, and D only)	★
M6	LCD display for SST housing (housing codes J, K, L, and M only)	★
Calibration certificate		
Q4	Calibration Certificate	★
QG	Calibration Certificate and GOST Verification Certificate	★
QP	Calibration certification and tamper evident seal	★
Material Traceability Certification⁽¹⁴⁾		
Q8	Material Traceability Certification per EN 10204 3.1	★
Quality Certification for Safety		
QS	Certificate of FMEDA Data	★
Zero/span adjustment⁽¹⁵⁾⁽¹⁶⁾		
J1	Local zero adjustment only	★
J3	No local zero or span adjustment	★
Transient protection terminal block		
T1	Transient protection terminal block	★
Software configuration⁽¹⁵⁾		
C1	Custom software configuration (Completed Rosemount 3051 Configuration Data Sheet required with order)	★
Low power output⁽¹⁵⁾		
C2	0.8–3.2 Vdc Output with Digital Signal Based on HART Protocol (Output Code M only)	
Gage pressure calibration		
C3	Gage Calibration (Rosemount 3051CA4 only)	★
Alarm limit⁽¹⁵⁾⁽¹⁷⁾		
C4	Analog output levels compliant with NAMUR Recommendation NE 43, Alarm High	★
CN	Analog output levels compliant with NAMUR Recommendation NE 43, Alarm Low	★
Pressure testing		
P1	Hydrostatic testing with certificate	
Cleaning process area		
P2	Cleaning for special service	
P3	Cleaning for <1 PPM chlorine/fluorine	

Table A-7. Rosemount 3051C Coplanar Pressure Transmitter Ordering Information

The starred offerings (★) represent the most common options and should be selected for best delivery. The non-starred offerings are subject to additional delivery lead time.

Pressure calibration		
P4	Calibrate at Line Pressure (Specify Q48 on order for corresponding certificate)	
High accuracy		
P8	0.04% accuracy to 5:1 turndown (Range 2-4)	★
Flange adapters		
DF	1/2–14 NPT flange adapter(s)	★
Vent/drain valves		
D7	Coplanar flange without drain/vent ports	
Conduit plug		
DO	316 SST Conduit Plug	★
RC ¹ / ₄ RC ¹ / ₂ process connection		
D9	JIS Process Connection—RC 1/4 flange with RC 1/2 flange adapter	
Max static line pressure		
P9	4500 psig static pressure limit (Rosemount 3051CD Ranges 2–5 only)	★
Ground screw ⁽¹⁰⁾		
V5	External ground screw assembly	★
Drinking water approval		
DW	NSF drinking water approval	★
Surface finish		
Q16	Surface finish certification for sanitary remote seals	★
Toolkit total system performance reports		
QZ	Remote seal system performance calculation report	★
Conduit electrical connector		
GE	M12, 4-pin, male connector (eurofast®)	★
GM	A size mini, 4-pin, male connector (minifast®)	★
Typical model number: 3051CD 2 A 2 2 A 1 A B4		

- Rosemount 3051CG lower range limit varies with atmospheric pressure.
- Rosemount 3051CD0 is available only with Output Code A, Process Flange Code 0 (Alternate Flange H2, H7, HJ, or HK), Isolating Diaphragm Code 2, O-ring Code A, and Bolting Option L4.
- Option code M4 - LCD display with Local Operator Interface required for local addressing and configuration.
- Not available with hazardous locations certification Options Codes I1, N1, E4, K6, and K8.
- Materials of Construction comply with recommendations per NACE MR0175/ISO 15156 for sour oil field production environments. Environmental limits apply to certain materials. Consult latest standard for details. Selected materials also conform to NACE MR0103 for sour refining environments.
- Available on Rosemount 3051CD and CG, Ranges 2–5 only. Not available on Rosemount 3051CA.
- Not available on Rosemount 3051CD0
- “Assemble-to” items are specified separately and require a completed model number.
- With the primary element installed, the maximum operating pressure will equal the lesser of either the transmitter or the primary element. Option is available for factory assembly to range 1–4 transmitters only.

10. The V5 option is not needed with the T1 option; external ground screw assembly is included with the T1 option.
11. Not available with Low Power code M.
12. Limited availability depending on transmitter type and range. Contact an Emerson representative.
13. Available only with output code W - PROFIBUS PA.
14. Only available for the sensor module housing and Coplanar or traditional flanges and adapters (3051C), and for the sensor module housing and low-volume Coplanar flange and adapter (Rosemount 3051C with Option Code S1).
15. Not available with Fieldbus (output code F) or PROFIBUS (output code W).
16. Local zero and span adjustments are standard unless Option Code J1 or J3 is specified.
17. NAMUR-Compliant operation is pre-set at the factory and cannot be changed to standard operation in the field.

Table A-8. Rosemount 3051L Level Transmitter Ordering Information

The starred offerings (★) represent the most common options and should be selected for best delivery. The non-starred offerings are subject to additional delivery lead time.

Model	Transmitter type		
3051T	Pressure transmitter		
Pressure type			
G	Gage		★
A	Absolute		★
Pressure upper range limit - configurable description			
	Rosemount 3051TG⁽¹⁾	Rosemount 3051TA	
1	30 psi (2,1 bar)	30 psia (2,1 bar)	★
2	150 psi (10,3 bar)	150 psia (10,3 bar)	★
3	800 psi (55,2 bar)	800 psia (55,2 bar)	★
4	4000 psi (275,8 bar)	4000 psia (275,8 bar)	★
5	10000 psi (689,5 bar)	10000 psia (689,5 bar)	★
Transmitter output			
A	4–20 mA with Digital Signal Based on HART Protocol		★
F	FOUNDATION Fieldbus Protocol		★
W ⁽²⁾	PROFIBUS PA Protocol		★
M	Low-Power 1–5 Vdc with Digital Signal Based on HART Protocol		
Process connection style			
2B	1/2–14 NPT Female		★
2C	G1/2 A DIN 16288 Male (Available in SST for Range 1–4 only)		★
2F	Coned and threaded, compatible with autoclave Type F-250-C (Includes gland and collar, available in SST for Range 5 only)		
61	Non-threaded Instrument flange (Range 1-4 only)		
	Isolating diaphragm	Process connection wetted parts material	
2 ⁽³⁾	316L SST	316L SST	★
3 ⁽³⁾	Alloy C-276	Alloy C-276	★
Sensor fill fluid			
1	Silicone		★
2	Inert (Fluorinert® FC-43)		★
	Housing material	Conduit entry size	
A	Polyurethane-covered Aluminum	1/2–14 NPT	★
B	Polyurethane-covered Aluminum	M20 × 1.5 (CM20)	★
J	SST	1/2–14 NPT	★
K	SST	M20 × 1.5 (CM20)	★

Table A-8. Rosemount 3051L Level Transmitter Ordering Information

The starred offerings (★) represent the most common options and should be selected for best delivery. The non-starred offerings are subject to additional delivery lead time.

D	Polyurethane-covered Aluminum	G½	
M	SST	G½	

Options (Include with selected model number)

Plantweb control functionality		
A01	Advanced control function block suite	★
Plantweb diagnostic functionality		
D01	FOUNDATION Fieldbus Diagnostics Suite	★
Integral assembly⁽⁴⁾		
S5	Assemble to Rosemount 306 Integral Manifold	★
Seal assemblies⁽⁴⁾		
S1	Assemble to one Rosemount 1199 seal	★
Mounting bracket		
B4	Bracket for 2-in. pipe or panel mounting, all SST	★
Product certifications		
C6	CSA Explosion-proof, Dust Ignition-proof, Intrinsically Safe, and Division 2	★
E2	INMETRO Flameproof	★
E3	China Flameproof	★
E4 ⁽⁵⁾	TIIS Flameproof	★
E5	FM Explosion-proof, Dust Ignition-proof	★
E7 ⁽⁵⁾	IECEx Flameproof, Dust Ignition-proof	★
E8	ATEX Flameproof and Dust	★
I1 ⁽⁵⁾	ATEX Intrinsic Safety and Dust	★
I2	INMETRO Intrinsic Safety	★
I3	China Intrinsic Safety	★
I5	FM Intrinsically Safe, Division 2	★
I7 ⁽⁵⁾	IECEx Intrinsic Safety	★
IA	ATEX Intrinsic Safety for FISCO; for FOUNDATION Fieldbus protocol only	★
IE	FM FISCO Intrinsically Safe; for FOUNDATION Fieldbus protocol only	★
K2	INMETRO Flameproof, Intrinsic Safety	★
K5	FM Explosion-proof, Dust Ignition-proof, Intrinsically Safe, and Division 2	★
K6 ⁽⁵⁾	CSA and ATEX Explosion-proof, Intrinsically Safe, and Division 2 (combination of C6 and K8)	★
K7 ⁽⁵⁾	IECEx Flameproof, Dust Ignition-proof, Intrinsic Safety, and Type n (combination of I7, N7, and E7)	★
K8 ⁽⁵⁾	ATEX Flame-proof, Intrinsic Safety, Type n, Dust (combination of E8, I1, and N1)	★

Table A-8. Rosemount 3051L Level Transmitter Ordering Information

The starred offerings (★) represent the most common options and should be selected for best delivery. The non-starred offerings are subject to additional delivery lead time.

KB	FM and CSA Explosion-proof, Dust Ignition-proof, Intrinsically Safe, and Division 2 (combination of K5 and C6)	★
KD ⁽⁵⁾	FM, CSA, and ATEX Explosion-proof, Intrinsically Safe (combination of K5, C6, I1, and E8)	★
N1 ⁽⁵⁾	ATEX Type n Certification and Dust	★
N3	China Type n	★
N7 ⁽⁵⁾	IECEX Type n Certification	★
Custody transfer⁽⁶⁾		
C5	Measurement Canada Accuracy Approval	★
Calibration certification		
Q4	Calibration Certificate	★
QG	Calibration Certificate and GOST Verification Certificate	★
QP	Calibration Certification and tamper evident seal	★
Material Traceability Certification⁽⁷⁾		
Q8	Material Traceability Certification per EN 10204 3.1	★
Quality Certification for Safety		
QS	Certificate of FMEDA Data	★
QT	Safety certified to IEC 61508 with Certificate of FMEDA data	★
Zero/span adjustment⁽⁸⁾⁽⁹⁾		
J1	Local zero adjustment only	★
J3	No local zero or span adjustment	★
D1	Hardware adjustments (zero, span, alarm, security)	
Display type		
M4 ⁽¹⁰⁾	LCD display with Local Operator Interface	★
M5	LCD display	★
M6	LCD display for SST Housing (housing codes J, K, L and M only)	★
Conduit plug		
DO	316 SST Conduit Plug	★
Transient terminal block		
T1	Transient protection terminal block	★
Software configuration⁽⁸⁾		
C1	Custom Software Configuration (Completed Configuration Data Sheet required with order)	★
C2	0.8–3.2 Vdc output with digital signal based on HART Protocol (output code M only)	

Table A-8. Rosemount 3051L Level Transmitter Ordering Information

The starred offerings (★) represent the most common options and should be selected for best delivery. The non-starred offerings are subject to additional delivery lead time.

Alarm limit		
C4 ⁽⁹⁾⁽¹¹⁾	Analog Output Levels Compliant with NAMUR Recommendation NE 43, Alarm High	★
CN ⁽⁹⁾⁽¹¹⁾	Analog Output Levels Compliant with NAMUR Recommendation NE 43, Low Alarm	★
CR	Custom alarm and saturation signal levels, high alarm	★
CS	Custom alarm and saturation signal levels, low alarm	★
CT	Low alarm (standard Rosemount alarm and saturation levels)	★
Pressure testing		
P1	Hydrostatic Testing with Certificate	
Cleaning process area		
P2	Cleaning for special service	
P3	Cleaning for <1 PPM chlorine/fluorine	
High accuracy		
P8	0.04% accuracy to 5:1 turndown (Range 2–4)	★
Ground screw ⁽¹²⁾		
V5	External ground screw assembly	★
Drinking water approval		
DW	NSF drinking water approval	★
Surface finish		
Q16	Surface finish certification for sanitary remote seals	★
Toolkit total system performance reports		
QZ	Remote seal system performance calculation report	★
Conduit electrical connector		
GE	M12, 4-pin, male connector (eurofast®)	★
GM	A size Mini, 4-pin, male connector (minifast®)	★
Typical model number: 3051T G 5 F 2A 2 1 A B4		

- Rosemount 3051TG lower range limit varies with atmospheric pressure.
- Option code M4 - LCD Display with Local Operator Interface required for local addressing and configuration.
- Materials of Construction comply with recommendations per NACE MR0175/ISO 15156 for sour oil field production environments. Environmental limits apply to certain materials. Consult latest standard for details. Selected materials also conform to NACE MR0103 for sour refining environments.
- “Assemble-to” items are specified separately and require a completed model number.
- Not available with low-power Option Code M.
- Limited availability depending on transmitter type and range. Contact an Emerson Representative.
- This option applies to the process connection only.
- Not available with fieldbus (output code F) or PROFIBUS protocols (output code W).
- Local zero and span adjustments are standard unless Option Code J1 or J3 is specified.
- Available only with output code W - PROFIBUS PA.
- NAMUR-Compliant operation is pre-set at the factory and cannot be changed to standard operation in the field.
- The V5 option is not needed with T1 option; external ground screw assembly is included with the T1 option.

Table A-9. Rosemount 3051L Liquid Level Transmitter Ordering Information

The starred offerings (★) represent the most common options and should be selected for best delivery. The non-starred offerings are subject to additional delivery lead time.

Model	Transmitter type			
3051L	Liquid level transmitter			
Pressure range				
2	–250 to 250 inH ₂ O (–0,6 to 0,6 bar)			★
3	–1000 to 1000 inH ₂ O (–2,5 to 2,5 bar)			★
4	–300 to 300 psi (–20,7 to 20,7 bar)			★
Transmitter output				
A	4–20 mA with Digital Signal Based on HART Protocol			★
F	FOUNDATION Fieldbus Protocol			★
W ⁽¹⁾	PROFIBUS PA Protocol			★
M ⁽²⁾	Low-Power 1–5 Vdc with Digital Signal Based on HART Protocol (See option code C2 for 0.8–3.2 Vdc Output)			
Process Connection Size, Material, Extension length (High Side)				
Code	Process connection size	Material	Extension length	
G0 ⁽³⁾	2-in./DN 50	316L SST	Flush mount only	★
H0 ⁽³⁾	2-in./DN 50	Alloy C-276	Flush mount only	★
J0	2-in./DN 50	Tantalum	Flush mount only	★
A0 ⁽³⁾	3-in./DN 80	316L SST	Flush mount	★
A2 ⁽³⁾	3-in./DN 80	316L SST	2-in./50 mm	★
A4 ⁽³⁾	3-in./DN 80	316L SST	4-in./100 mm	★
A6 ⁽³⁾	3-in./DN 80	316L SST	6-in./150 mm	★
B0 ⁽³⁾	4-in./DN 100	316L SST	Flush mount	★
B2 ⁽³⁾	4-in./DN 100	316L SST	2-in./50 mm	★
B4 ⁽³⁾	4-in./DN 100	316L SST	4-in./100 mm	★
B6 ⁽³⁾	4-in./DN 100	316L SST	6-in./150 mm	★
C0 ⁽³⁾	3-in./DN 80	Alloy C-276	Flush mount	★
C2 ⁽³⁾	3-in./DN 80	Alloy C-276	2-in./50 mm	★
C4 ⁽³⁾	3-in./DN 80	Alloy C-276	4-in./100 mm	★
C6 ⁽³⁾	3-in./DN 80	Alloy C-276	6-in./150 mm	★
D0 ⁽³⁾	4-in./DN 100	Alloy C-276	Flush mount	★
D2 ⁽³⁾	4-in./DN 100	Alloy C-276	2-in./50 mm	★
D4 ⁽³⁾	4-in./DN 100	Alloy C-276	4-in./100 mm	★
D6 ⁽³⁾	4-in./DN 100	Alloy C-276	6-in./150 mm	★
E0	3-in./DN 80	Tantalum	Flush mount only	★
F0	4-in./DN 100	Tantalum	Flush mount only	★

Table A-9. Rosemount 3051L Liquid Level Transmitter Ordering Information

The starred offerings (★) represent the most common options and should be selected for best delivery. The non-starred offerings are subject to additional delivery lead time.

Mounting flange size, rating, material (high side)				
M	2-in.	ANSI/ASME B16.5 Class 150	CS	★
A	3-in.	ANSI/ASME B16.5 Class 150	CS	★
B	4-in.	ANSI/ASME B16.5 Class 150	CS	★
N	2-in.	ANSI/ASME B16.5 Class 300	CS	★
C	3-in.	ANSI/ASME B16.5 Class 300	CS	★
D	4-in.	ANSI/ASME B16.5 Class 300	CS	★
P	2-in.	ANSI/ASME B16.5 Class 600	CS	★
E	3-in.	ANSI/ASME B16.5 Class 600	CS	★
X ⁽³⁾	2-in.	ANSI/ASME B16.5 Class 150	SST	★
F ⁽³⁾	3-in.	ANSI/ASME B16.5 Class 150	SST	★
G ⁽³⁾	4-in.	ANSI/ASME B16.5 Class 150	SST	★
Y ⁽³⁾	2-in.	ANSI/ASME B16.5 Class 300	SST	★
H ⁽³⁾	3-in.	ANSI/ASME B16.5 Class 300	SST	★
J ⁽³⁾	4-in.	ANSI/ASME B16.5 Class 300	SST	★
Z ⁽³⁾	2-in.	ANSI/ASME B16.5 Class 600	SST	★
L ⁽³⁾	3-in.	ANSI/ASME B16.5 Class 600	SST	★
Q	DN 50	PN 10-40 per EN 1092-1	CS	★
R	DN 80	PN 40 per EN 1092-1	CS	★
S	DN 100	PN 40 per EN 1092-1	CS	★
V	DN 100	PN 10/16 per EN 1092-1	CS	★
K ⁽³⁾	DN 50	PN 10-40 per EN 1092-1	SST	★
T ⁽³⁾	DN 80	PN 40 per EN 1092-1	SST	★
U ⁽³⁾	DN 100	PN 40 per EN 1092-1	SST	★
W ⁽³⁾	DN 100	PN 10/16 per EN 1092-1	SST	★
7 ⁽³⁾	4 in.	ANSI/ASME B16.5 Class 600	SST	★
1	N/A	10K per JIS B2238	CS	
2	N/A	20K per JIS B2238	CS	
3	N/A	40K per JIS B2238	CS	
4 ⁽³⁾	N/A	10K per JIS B2238	316 SST	
5 ⁽³⁾	N/A	20K per JIS B2238	316 SST	
6 ⁽³⁾	N/A	40K per JIS B2238	316 SST	

Table A-9. Rosemount 3051L Liquid Level Transmitter Ordering Information

The starred offerings (★) represent the most common options and should be selected for best delivery. The non-starred offerings are subject to additional delivery lead time.

Code	Process fill-high pressure side	Specific gravity	Temperature limits (ambient temperature of 70 °F [21 °C])		
A	Syltherm XLT	0.85	-102 to 293 °F (-75 to 145 °C)		★
C	Silicone 704	1.07	32 to 401 °F (0 to 205 °C)		★
D	Silicone 200	0.93	-49 to 401 °F (-45 to 205 °C)		★
H	Inert (Halocarbon)	1.85	-49 to 320 °F (-45 to 160 °C)		★
G	Glycerine and Water	1.13	5 to 203 °F (-15 to 95 °C)		★
N	Neobee M-20	0.92	5 to 401 °F (-15 to 205 °C)		★
P	Propylene Glycol and Water	1.02	5 to 203 F (-15 to 95 °C)		★
Low Pressure Side ⁽³⁾					
	Configuration	Flange adapter	Diaphragm Material	Sensor Fill Fluid	
11	Gage	SST	316L SST	Silicone	★
21	Differential	SST	316L SST	Silicone	★
22	Differential	SST	Alloy C-276	Silicone	★
2A	Differential	SST	316L SST	Inert (Halocarbon)	★
2B	Differential	SST	Alloy C-276	Inert (Halocarbon)	★
31	Tuned-system assembly with remote seal	None	316L SST	Silicone (requires option code S1)	★
O-ring					
A	Glass-filled PTFE				★
	Housing material	Conduit entry size			
A	Aluminum	1/2-14 NPT			★
B	Aluminum	M20 × 1.5			★
J	SST	1/2-14 NPT			★
K	SST	M20 × 1.5			★
D	Aluminum	G1/2			
M	SST	G1/2			

Options (Include with selected model number)

Plantweb control functionality		
A01	FOUNDATION Fieldbus advanced control function block suite	★

Table A-9. Rosemount 3051L Liquid Level Transmitter Ordering Information

The starred offerings (★) represent the most common options and should be selected for best delivery. The non-starred offerings are subject to additional delivery lead time.

Plantweb Diagnostic Functionality		
D01	FOUNDATION Fieldbus Diagnostics Suite	★
Seal assemblies⁽⁴⁾		
S1	Assembled to One Rosemount 1199 Seal (Requires 1199M)	★
Product certifications		
E5	FM Explosion-proof, Dust Ignition-proof	★
I5	FM Intrinsically Safe, Division 2	★
K5	FM Explosion-proof, Dust Ignition-proof, Intrinsically Safe, and Division 2	★
I1 ⁽⁵⁾	ATEX Intrinsic Safety and Dust	★
N1 ⁽⁵⁾	ATEX Type n Certification and Dust	★
E8	ATEX Flameproof and Dust	★
E4 ⁽⁵⁾	TIIS Flameproof	★
C6	CSA Explosion-proof, Dust Ignition-proof, Intrinsically Safe, and Division 2	★
K6 ⁽⁵⁾	CSA and ATEX Explosion-proof, Intrinsically Safe, and Division 2 (combination of C6 and K8)	★
KB	FM and CSA Explosion-proof, Dust Ignition-proof, Intrinsically Safe, and Division 2 (combination of K5 and C6)	★
K7 ⁽⁵⁾	IECEX Flameproof, Dust Ignition-proof, Intrinsic Safety, and Type n (combination of I7, N7, and E7)	★
K8 ⁽⁵⁾	ATEX Flame-proof and Intrinsic Safety Approvals (combination of I1 and E8)	★
KD ⁽⁵⁾	FM, CSA, and ATEX Explosion-proof, Intrinsically Safe (combination of K5, C6, I1, and E8)	★
I7 ⁽⁵⁾	IECEX Intrinsic Safety	★
E7 ⁽⁵⁾	IECEX Flameproof, Dust Ignition-proof	★
N7 ⁽⁵⁾	IECEX Type n Certification	★
IA	ATEX FISCO Intrinsic Safety	★
IE	FM FISCO Intrinsically Safe	★
E2	INMETRO Flameproof	★
I2	INMETRO Intrinsic Safety	★
K2	INMETRO Flameproof, Intrinsic Safety	★
E3	China Flameproof	★
I3	China Intrinsic Safety	★
N3	China Type n	★
Bolting material		
L4	Austenitic 316 SST bolts	★
L5	ASTM A 193, Grade B7M bolts	★
L6	Alloy K-500 bolts	★
L8	ASTM A 193 Class 2, Grade B8M bolts	★

Table A-9. Rosemount 3051L Liquid Level Transmitter Ordering Information

The starred offerings (★) represent the most common options and should be selected for best delivery. The non-starred offerings are subject to additional delivery lead time.

Display type		
M4 ⁽⁶⁾	LCD display with Local Operator Interface	★
M5	LCD display for aluminum housing (housing codes A, B, C, and D only)	★
M6	LCD display for SST housing (housing codes J, K, L, and M only)	★
Calibration certification		
Q4	Calibration Certificate	★
QP	Calibration Certificate and tamper evident seal	★
QG	Calibration Certificate and GOST Verification Certificate	★
Material traceability certification		
Q8	Material Traceability Certification per EN 10204 3.1	★
Quality certification for safety⁽⁷⁾		
QS	Prior-use certificate of FMEDA data	★
Toolkit total system performance reports		
QZ	Remote seal system performance calculation report	★
Conduit electrical connector		
GE	M12, 4-pin, male connector (eurofast [®])	★
GM	A size mini, 4-pin, male connector (minifast [®])	★
Hardware adjustments⁽⁸⁾⁽⁹⁾		
J1	Local zero adjustment only	★
J3	No local zero or span adjustment	★
Transient protection⁽¹⁰⁾		
T1	Transient protection terminal block	★
Software configuration⁽⁸⁾		
C1	Custom Software Configuration (Completednt Rosemount 3051 Configuration Data Sheet required with order)	★
Low power output⁽⁸⁾		
C2	0.8–3.2 Vdc Output with digital signal based on HART Protocol (Available with Output code M only)	★
Alarm limit		
C4 ⁽⁸⁾⁽¹²⁾	NAMUR alarm and saturation levels, high alarm	★
CN ⁽⁸⁾⁽¹²⁾	NAMUR alarm and saturation levels, low alarm	★
CR	Custom alarm and saturation signal levels, high alarm	★
CS	Custom alarm and saturation signal levels, low alarm	★
CT	Low alarm (standard Rosemount alarm and saturation levels)	★

Table A-9. Rosemount 3051L Liquid Level Transmitter Ordering Information

The starred offerings (★) represent the most common options and should be selected for best delivery. The non-starred offerings are subject to additional delivery lead time.

Conduit plug				
D0	316 SST Conduit Plug			★
Ground screw ⁽¹¹⁾				
V5	External ground screw assembly			★
Lower housing flushing connection options				
	Ring material	Number	Size (NPT)	
F1	316 SST	1	1/4-18 NPT	★
F2	316 SST	2	1/4-18 NPT	★
F3	Alloy C-276	1	1/4-18 NPT	★
F4	Alloy C-276	2	1/4-18 NPT	★
F7	316 SST	1	1/2-14 NPT	★
F8	316 SST	2	1/2-14 NPT	★
F9	Alloy C-276	1	1/2-14 NPT	★
F0	Alloy C-276	2	1/2-14 NPT	★
Typical model number: 3051L 2 A A0 D 21 A A F1				

1. Option code M4 - LCD display with Local Operator Interface required for local addressing and configuration.
2. Not available with hazardous certification Option Codes I1, N1, E4, K6, and K8.
3. Materials of Construction comply with metallurgical requirements highlighted within NACE MR0175/ISO 15156 for sour oil field production environments. Environmental limits apply to certain materials. Consult latest standard for details. Selected materials also conform to NACE MR0103 for sour refining environments.
4. "Assemble-to" items are specified separately and require a completed model number.
5. Not available with low-power Option Code M
6. Available only with output code W - PROFIBUS PA.
7. Only available with HART 4-20 mA output (output code A).
8. Not available with Fieldbus (output code F) or PROFIBUS protocols (output code W).
9. Local zero and span adjustments are standard unless Option Code J1 or J3 is specified.
10. The T1 option is not needed with FISCO Product Certifications; transient protection is included in the FISCO product certification codes IA, IE, IF, and IG.
11. The V5 option is not needed with the T1 option; external ground screw assembly is included with the T1 option.

A.6 Options

Standard configuration

Unless otherwise specified, transmitter is shipped as follows:

Differential/gage:	inH ₂ O (Range 0, 1, 2, and 3) psi (Range 4 and 5)
Absolute/ Rosemount 3051T:	psi (all ranges)
4 mA (1 Vdc) ⁽¹⁾ :	0 (engineering units above)
20 mA (5 Vdc):	Upper range limit
Output:	Linear
Flange type:	Specified model code option
Flange material:	Specified model code option
O-ring material:	Specified model code option
Drain/vent:	Specified model code option
Integral meter:	Installed or none
Alarm ⁽¹⁾ :	Upscale
Software tag:	N/A

1. Not applicable to Fieldbus.

Custom configuration HART protocol only⁽¹⁾

If option code C1 is ordered, the customer may specify the following data in addition to the standard configuration parameters.

- Output information
- Transmitter information
- LCD display configuration
- Hardware selectable information
- Signal selection

Refer to the HART Protocol C1 Option [Configuration Data Sheet](#).

1. Not applicable to Fieldbus.

Tagging (3 options available)

- Standard SST hardware tag is wired to the transmitter. Tag character height is 0.125-in. (3,18 mm), 56 characters maximum.
- Tag may be permanently stamped on transmitter nameplate upon request, 56 characters maximum.
- Tag may be stored in transmitter memory (30 characters maximum). Software tag is left blank unless specified.

Commissioning tag (fieldbus only)

A temporary commissioning tag is attached to all transmitters. The tag indicates the device ID and allows an area for writing the location.

Optional Rosemount 304, 305, or 306 Integral Manifolds

Factory assembled to Rosemount 3051C and 3051T transmitters. Refer to Rosemount Manifolds [Product Data Sheet](#) for additional information.

Optional diaphragm and sanitary seals

Refer to Rosemount DP Level Transmitters and 1199 Seal System [Product Data Sheet](#) for additional information.

Output Information⁽¹⁾

Output range points must be the same unit of measure. Available units of measure include:

inH ₂ O	inH ₂ O@4 °C ⁽¹⁾	psi	Pa
inHg	ftH ₂ O	bar	kPa
mmH ₂ O	mmH ₂ O@4 °C ⁽¹⁾	mbar	torr
mmHg	g/cm ²	kg/cm ²	atm

1. Not available on low power or previous versions.

LCD display

M5 Digital Display, 5-Digit, 2-Line LCD

- Direct reading of digital data for higher accuracy
- Displays user-defined flow, level, volume, or pressure units
- Displays diagnostic messages for local troubleshooting
- 90 degree rotation capability for easy viewing

M6 Digital display with 316 stainless steel cover

- For use with stainless steel housing option (housing codes J, K, and L)

Local span and zero adjustment⁽¹⁾

Transmitters ship with local span and zero adjustments standard unless otherwise specified.

- Non-interactive external zero and span adjustments ease calibration
- Magnetic switches replace standard potentiometer adjustments to optimize performance

J1 Local zero adjustment only

J3 No local zero or span adjustment

Bolts for flanges and adapters

- Options permit bolts for flanges and adapters to be obtained in various materials
- Standard material is plated carbon steel per ASTM A449, Type 1

L4 Austenitic 316 stainless steel bolts

L5 ASTM A 193, Grade B7M bolts

L6 Alloy K-500 bolts

Rosemount 3051C Coplanar Flange and Rosemount 3051T bracket option

B4 Bracket for 2-in. pipe or panel mounting

- For use with the standard Coplanar flange configuration
- Bracket for mounting of transmitter on 2-in. pipe or panel
- Stainless steel construction with stainless steel bolts

Rosemount 3051H bracket options

B5 Bracket for 2-in. pipe or panel mounting

- For use with the Rosemount 3051H Transmitter for high process temperatures
- Carbon steel construction with carbon steel bolts

B6 B5 Bracket with SST bolts

- Same bracket as the B5 option with Series 300 stainless steel bolts.

Traditional flange bracket options

B1 Bracket for 2-in. pipe mounting

- For use with the traditional flange option
- Bracket for mounting on 2-in. pipe
- Carbon steel construction with carbon steel bolts

■ Coated with polyurethane paint

B2 Bracket for panel mounting

- For use with the traditional flange option
- Bracket for mounting transmitter on wall or panel
- Carbon steel construction with carbon steel bolts

■ Coated with polyurethane paint

B3 Flat Bracket for 2-in. Pipe Mounting

- For use with the traditional flange option
- Bracket for vertical mounting of transmitter on 2-in. pipe
- Carbon steel construction with carbon steel bolts

■ Coated with polyurethane paint

B7 B1 bracket with SST bolts

- Same bracket as the B1 option with Series 300 stainless steel bolts

B8 B2 bracket with SST bolts

- Same bracket as the B2 option with Series 300 stainless steel bolts

B9 B3 bracket with SST bolts

- Same bracket as the B3 option with Series 300 stainless steel bolts

BA Stainless steel B1 bracket with SST bolts

- B1 bracket in stainless steel with Series 300 stainless steel bolts

BC Stainless steel B3 bracket with SST bolts

- B3 bracket in stainless steel with Series 300 stainless steel bolts

Shipping weights

Table A-10. Transmitter Weights without Options

Transmitter	Add weight In lb (kg)
Rosemount 3051C	6.0 (2,7)
Rosemount 3051L	Table A-11
Rosemount 3051H	13.6 (6,2)
Rosemount 3051T	3.0 (1,4)

Table A-11. Rosemount 3051L Weights without Options

Flange	Flush lb. (kg)	2-in. Ext. lb (kg)	4-in. Ext. lb (kg)	6-in. Ext. lb (kg)
2-in., Class 150	12.5 (5,7)	N/A	N/A	N/A
3-in., Class 150	17.5 (7,9)	19.5 (8,8)	20.5 (9,3)	21.5 (9,7)
4-in., Class 150	23.5 (10,7)	26.5 (12,0)	28.5 (12,9)	30.5 (13,8)
2-in., Class 300	17.5 (7,9)	N/A	N/A	N/A
3-in., Class 300	22.5 (10,2)	24.5 (11,1)	25.5 (11,6)	26.5 (12,0)
4-in., Class 300	32.5 (14,7)	35.5 (16,1)	37.5 (17,0)	39.5 (17,9)
2-in., Class 600	15.3 (6,9)	N/A	N/A	N/A
3-in., Class 600	25.2 (11,4)	27.2 (12,3)	28.2 (12,8)	29.2 (13,2)
DN 50/PN 40	13.8 (6,2)	N/A	N/A	N/A
DN 80/PN 40	19.5 (8,8)	21.5 (9,7)	22.5 (10,2)	23.5 (10,6)
DN 100/PN 10/16	17.8 (8,1)	19.8 (9,0)	20.8 (9,5)	21.8 (9,9)
DN 100/PN 40	23.2 (10,5)	25.2 (11,5)	26.2 (11,9)	27.2 (12,3)

Table A-12. Transmitter Options Weights

Code	Option	Add lb (kg)
J, K, L, M	Stainless steel housing (T)	3.9 (1,8)
J, K, L, M	Stainless steel housing (C, L, H, P)	3.1 (1,4)
M5	LCD display for Aluminum Housing	0.5 (0,2)
M6	LCD display for SST Housing	1.25 (0,6)
B4	SST mounting bracket for coplanar flange	1.0 (0,5)
B1, B2, B3	Mounting bracket for traditional flange	2.3 (1,0)
B7, B8, B9	Mounting bracket for traditional flange	2.3 (1,0)
BA, BC	SST bracket for traditional flange	2.3 (1,0)
B5, B6	Mounting bracket for 3051H	2.9 (1,3)
H2	Traditional flange	2.4 (1,1)
H3	Traditional flange	2.7 (1,2)
H4	Traditional flange	2.6 (1,2)
H7	Traditional flange	2.5 (1,1)
FC	Level Flange—3 in., Class 150	10.8 (4,9)

Table A-12. Transmitter Options Weights

Code	Option	Add lb (kg)
FD	Level Flange—3 in., Class 300	14.3 (6,5)
FA	Level Flange—2 in., Class 150	10.7 (4,8)
FB	Level Flange—2 in., Class 300	14.0 (6,3)
FP	DIN Level Flange, SST, DN 50, PN 40	8.3 (3,8)
FQ	DIN Level Flange, SST, DN 80, PN 40	13.7 (6,2)

Table A-13. Rosemount 3051C Differential/Gage Pressure Transmitter Range Limits⁽¹⁾

Units	Range 1 span		Range 2 span		Range 3 span		Range 4 span		Range 5 span	
	Min	Max	Min	Max	Min	Max	Min	Max	Min	Max
inH ₂ O	0.5	25	2.5	250	10	1000	83.040	8304	553.60	55360
inHg	0.03678	1.8389	0.18389	18.389	0.73559	73.559	6.1081	610.81	40.720	4072.04
ftH ₂ O	0.04167	2.08333	0.20833	20.8333	0.83333	83.3333	6.9198	691.997	46.13	4613.31
mmH ₂ O	12.7	635.5	63.553	6355	254	25421	2110.95	211095	14073	1407301
mmHg	0.93416	46.7082	4.67082	467.082	18.6833	1868.33	155.145	15514.5	1034.3	103430
psi	0.01806	0.903	0.0902	9.03183	0.36127	36.127	3	300	20	2000
bar	0.00125	0.06227	0.00623	0.62272	0.02491	2.491	0.20684	20.6843	1.37895	137.895
mbar	1.2454	62.2723	6.22723	622.723	24.9089	2490.89	206.843	20684.3	1378.95	137895
g/cm ²	1.26775	63.3875	6.33875	633.875	25.355	2535.45	210.547	21054.7	1406.14	140614
kg/cm ²	0.00127	0.0635	0.00635	0.635	0.0254	2.54	0.21092	21.0921	1.40614	140.614
Pa	124.545	6227.23	622.723	62160.6	2490.89	249089	20684.3	2068430	137895	13789500
kPa	0.12545	6.2272	0.62272	62.2723	2.49089	249.089	20.6843	2068.43	137.895	13789.5
torr	0.93416	46.7082	4.67082	467.082	18.6833	1868.33	155.145	15514.5	1034.3	103430
atm	0.00123	0.06146	0.00615	0.61460	0.02458	2.458	0.20414	20.4138	1.36092	136.092

1. When using a Field Communicator, ±5% adjustment is allowed on the sensor limit to allow for unit conversions.

Table A-14. Rosemount 3051L/3051H Pressure Transmitter Range Limits⁽¹⁾

Units	Range 2 span		Range 3 span		Range 4 span		Range 5 span	
	Min	Max	Min	Max	Min	Max	Min	Max
inH ₂ O	2.5	250	10	1000	83.040	8304	553.60	55360
inHg	0.18389	18.389	0.73559	73.559	6.1081	610.81	40.720	4072.04
ftH ₂ O	0.20833	20.8333	0.83333	83.3333	6.9198	691.997	46.13	4613.31
mmH ₂ O	63.553	6355	254	25421	2110.95	211095	14073	1407301
mmHg	4.67082	467.082	18.6833	1868.33	155.145	15514.5	1034.3	103430
psi	0.0902	9.03183	0.36127	36.127	3	300	20	2000
bar	0.00623	0.62272	0.02491	2.491	0.20684	20.6843	1.37895	137.895
mbar	6.22723	622.723	24.9089	2490.89	206.843	20684.3	1378.95	137895
g/cm ²	6.33875	633.875	25.355	2535.45	210.547	21054.7	1406.14	140614
kg/cm ²	0.00635	0.635	0.0254	2.54	0.21092	21.0921	1.40614	140.614
Pa	622.723	62160.6	2490.89	249089	20684.3	2068430	137895	13789500
kPa	0.62272	62.2723	2.49089	249.089	20.6843	2068.43	137.895	13789.5
torr	4.67082	467.082	18.6833	1868.33	155.145	15514.5	1034.3	103430
atm	0.00615	0.61460	0.02458	2.458	0.20414	20.4138	1.36092	136.092

1. When using a Field Communicator, ±5% adjustment is allowed on the sensor limit to allow for unit conversions.

Table A-15. Rosemount 3051T Gage and Absolute Pressure Transmitter Range Limits (Range 1 and 2)⁽¹⁾

Units	Range 1 span		Range 2 span	
	Min	Max	Min	Max
inH ₂ O	8.30397	831.889	41.5198	4159.45
inHg	0.61081	61.0807	3.05403	305.403
ftH ₂ O	0.69199	69.3241	3.45998	345.998
mmH ₂ O	211.10	21130	1054.60	105460.3
mmHg	15.5145	1551.45	77.5723	7757.23
psi	0.3	30	1.5	150
bar	0.02068	2.06843	0.10342	10.3421
mbar	20.6843	2068.43	103.421	10342.11
g/cm ²	21.0921	2109.21	105.461	10546.1
kg/cm ²	0.02109	2.10921	0.10546	10.5461
Pa	2068.43	206843	10342.1	1034212
kPa	2.06843	206.843	10.3421	1034.21
torr	15.5145	1551.45	77.5726	7757.26
atm	0.02041	2.04138	0.10207	10.2069

1. When using a Field Communicator, ±5% adjustment is allowed on the sensor limit to allow for unit conversions.

Table A-16. Rosemount 3051T Gage and Absolute Pressure Transmitter Range Limits (Range 3, 4 and 5)⁽¹⁾

Units	Range 3 span		Range 4 span		Range 5 span	
	Min	Max	Min	Max	Min	Max
inH ₂ O	221.439	22143.9	1107.2	110720	55360	276799
inHg	16.2882	1628.82	81.441	8144.098	4072.04	20360.2
ftH ₂ O	18.4533	1845.33	92.2663	9226.63	4613.31	23066.6
mmH ₂ O	5634.66	563466	28146.1	2814613	1407301	7036507
mmHg	413.72	41372	2068.6	206860.0	103430	517151
psi	8	800	40	4000	2000	10000
bar	0.55158	55.1581	2.75791	275.7905	137.895	689.476
mbar	551.581	55158.1	2757.91	275790.5	137895	689476
g/cm ²	561.459	56145.9	2807.31	280730.6	140614	703067
kg/cm ²	0.56246	56.2456	2.81228	281.228	140.614	701.82
Pa	55158.1	5515811	275791	27579054	13789500	68947600
kPa	55.1581	5515.81	275.791	27579.05	13789.5	68947.6
torr	413.721	413721	2068.6	206859.7	103430	517151
atm	0.54437	54.4368	2.72184	272.1841	136.092	680.46

1. When using a Field Communicator, ±5% adjustment is allowed on the sensor limit to allow for unit conversions.

Table A-17. Rosemount 3051C Absolute Pressure Transmitter Range Limits⁽¹⁾

Units	Range 1 span		Range 2 span		Range 3 span		Range 4 span	
	Min	Max	Min	Max	Min	Max	Min	Max
inH ₂ O	8.30397	831.889	41.5198	4151.98	221.439	22143.9	1107.2	110720
inHg	0.61081	61.0807	3.05403	305.403	16.2882	1628.82	81.441	8144.098
ftH ₂ O	0.69199	69.3241	3.45998	345.998	18.4533	1845.33	92.2663	9226.63
mmH ₂ O	211.10	21130	6.35308	635.308	5634.66	563466	28146.1	2814613
mmHg	15.5145	1551.45	1055.47	105547	413.72	41372	2068.6	206860.0
psi	0.3	30	1.5	150	8	800	40	4000
bar	0.02068	2.06843	0.10342	10.342	0.55158	55.1581	2.75791	275.7905
mbar	20.6843	2068.43	103.421	10342.1	551.581	55158.1	2757.91	275790.5
g/cm ²	21.0921	2109.21	105.27	105.27	561.459	56145.9	2807.31	280730.6
kg/cm ²	0.02109	2.10921	0.10546	10.546	0.56246	56.2456	2.81228	281.228
Pa	2068.43	206843	10342.1	1034210	55158.1	5515811	275791	27579054
kPa	2.06843	206.843	10.3421	1034.21	55.1581	5515.81	275.791	27579.05
torr	15.5145	1551.45	77.5726	7757.26	413.721	413721	2068.6	206859.7
atm	0.02041	2.04138	0.10207	10.207	0.54437	54.4368	2.72184	272.1841

1. When using a Field Communicator, ±5% adjustment is allowed on the sensor limit to allow for unit conversions.

A.7 Spare parts

Rosemount 3051C Gage and Differential Sensor Modules (minimum span/range)		Silicone fill	Inert fill
		Part number	Part number
Note: One spare part is recommended for every 50 transmitters. Note: Listed by Range and Process Isolator Order Numbers.			
	Gage pressure range	Differential pressure range	
Range 1	-25 to 25 inH ₂ O/0.5 inH ₂ O	-25 to 25 inH ₂ O/0.5 inH ₂ O	
316L SST		03031-1045-0012	03031-1145-0012
Alloy C-276		03031-1045-0013	03031-1145-0013
Alloy 400		03031-1045-0014	03031-1145-0014
Gold-plated Alloy 400		03031-1045-0016	03031-1145-0016
Gold-plated 316 SST		03031-1045-0017	03031-1145-0017
Range 2	-250 to 250 inH ₂ O/2.5 inH ₂ O	-250 to 250 inH ₂ O/2.5 inH ₂ O	
316L SST		03031-1045-0022	03031-1145-0022
Alloy C-276		03031-1045-0023	03031-1145-0023
Alloy 400		03031-1045-0024	03031-1145-0024
Tantalum		03031-1045-0025	03031-1145-0025
Gold-plated Alloy 400		03031-1045-0026	03031-1145-0026
Gold-plated 316 SST		03031-1045-0027	03031-1145-0027
Range 3	-407 to 1000 inH ₂ O/10 inH ₂ O	-1000 to 1000 inH ₂ O/10 inH ₂ O	
316L SST		03031-1045-0032	03031-1145-0032
Alloy C-276		03031-1045-0033	03031-1145-0033
Alloy 400		03031-1045-0034	03031-1145-0034
Tantalum		03031-1045-0035	03031-1145-0035
Gold-plated Alloy 400		03031-1045-0036	03031-1145-0036
Gold-plated 316 SST		03031-1045-0037	03031-1145-0037
Range 4	-14.2 to 300 psi/3 psi	-300 to 300 psi/3 psi	
316L SST		03031-1045-2042	03031-1145-2042
Alloy C-276		03031-1045-2043	03031-1145-2043
Alloy 400		03031-1045-2044	03031-1145-2044
Tantalum		03031-1045-2045	03031-1145-2045
Gold-plated Alloy 400		03031-1045-2046	03031-1145-2046
Gold-plated 316 SST		03031-1045-2047	03031-1145-2047

Range 5	-14.2 to 2000 psi/20 psi	-2000 to 2000psi/20 psi	
316L SST		03031-1045-2052	03031-1145-2052
Alloy C-276		03031-1045-2053	03031-1145-2053
Alloy 400		03031-1045-2054	03031-1145-2054
Tantalum		03031-1045-2055	03031-1145-2055
Gold-plated Alloy 400		03031-1045-2056	03031-1145-2056
Gold-plated 316 SST		03031-1045-2057	03031-1145-2057

Rosemount 3051C absolute sensor modules (minimum span/range)	Silicone fill
	Part number
Range 1, 0 to 30 psia/0.3 psia	
316L SST	03031-2020-0012
Alloy C-276	03031-2020-0013
Alloy 400	03031-2020-0014
Gold-plated Alloy 400	03031-2020-0016
Gold-plated 316 SST	03031-2020-0017
Range 2, 0 to 150/1.5 psia	
316L SST	03031-2020-0022
Alloy C-276	03031-2020-0023
Alloy 400	03031-2020-0024
Gold-plated Alloy 400	03031-2020-0026
Gold-plated 316 SST	03031-2020-0027
Range 3, 0 to 800 psia/8 psia	
316L SST	03031-2020-0032
Alloy C-276	03031-2020-0033
Alloy 400	03031-2020-0034
Gold-plated Alloy 400	03031-2020-0036
Gold-plated 316 SST	03031-2020-0037
Range 4, 0 to 400 psia/40 psia	
316L SST	03031-2020-0042
Alloy C-276	03031-2020-0043
Alloy 400	03031-2020-0044
Gold-plated Alloy 400	03031-2020-0046
Gold-plated 316 SST	03031-2020-0047

Electronics board assemblies	Part number
4–20 mA HART Standard	03031-0001-0002
4–20 mA HART NAMUR compliant	03031-0001-0003
1–5 Vdc HART Low Power	03031-0001-1001
FOUNDATION Fieldbus	03031-0001-2001
PROFIBUS PA	03031-0001-2101
LCD display	
LCD display kits	
4–20 mA HART - Aluminum	03031-0193-0101
4–20 mA HART - 316 SST	03031-0193-0111
1–5 Vdc HART Low Power - Aluminum	03031-0193-0001
1–5 Vdc HART Low Power - 316 SST	03031-0193-0011
Fieldbus (FOUNDATION or PROFIBUS PA) - Aluminum	03031-0193-0104
Fieldbus (FOUNDATION or PROFIBUS PA) - 316 SST	03031-0193-0112
LCD display only	
4–20 mA HART	03031-0193-0103
1–5 Vdc HART Low Power	03031-0193-0003
Fieldbus (FOUNDATION or PROFIBUS PA)	03031-0193-0105
Terminal block assemblies	
4–20 mA HART output	
Standard terminal block	03031-0332-0003
Transient terminal block (option T1)	03031-0332-0004
1–5 Vdc HART low power output	
Standard terminal block	03031-0332-1001
Transient terminal block (option T1)	03031-0332-1002
Fieldbus (FOUNDATION or PROFIBUS PA)	
Standard terminal block	03031-0332-2001
Transient terminal block (option T1)	03031-0332-2002
FISCO terminal block	03031-0332-2005
Electrical housings (without terminal block)	
Standard - Aluminum	
1/2 - 14 NPT conduit entry	03031-0635-0001
M20 conduit entry	03031-0635-0002
G1/2 conduit entry	03031-0635-0004

Standard - 316 SST	
1/2-14 NPT conduit entry	03031-0635-0041
M20 conduit entry	03031-0635-0042
1-5 Vdc HART low power - aluminum	
1/2-14 NPT conduit entryver	03031-0635-0101
1-5 Vdc HART low power - 316 SST	
1/2-14 NPT conduit entry	03031-0635-0141
Housing conduit plugs	Part number
1/2 NPT Conduit plug	03031-0544-0003
M20 Conduit plug	03031-0544-0001
G1/2 Conduit plug	03031-0544-0004
Housing covers (include o-ring)	
Field terminal cover - Aluminum	03031-0292-0001
Field terminal cover - 316 SST	03031-0292-0002
HART electronics cover - Aluminum	03031-0292-0001
HART electronics cover - 316 SST	03031-0292-0002
HART LCD display cover - Aluminum	03031-0193-0002
HART LCD display cover - 316 SST	03031-0193-0012
Fieldbus extended electronics cover - Aluminum	03031-0292-0003
Fieldbus extended electronics cover - 316 SST	03031-0292-0004
Fieldbus extended LCD Display cover - Aluminum	03031-0193-0007
Fieldbus extended LCD Display cover - 316 SST	03031-0193-0013
Miscellaneous hardware	
Local zero and span kit	03031-0293-0002
External ground screw assembly (option V5)	03031-0398-0001
Flanges	
Differential Coplanar Flange	
316 SST	03031-0388-0022
Cast C-276	03031-0388-0023
Cast Alloy 400	03031-0388-0024
Nickel-plated carbon steel	03031-0388-0025
Gage/Absolute Coplanar Flange	
316 SST	03031-0388-1022
Cast C-276	03031-0388-1023
Cast Alloy 40	03031-0388-1024
Nickel-plated carbon steel	03031-0388-1025
Coplanar flange alignment screw (package of 12)	03031-0309-0001

Traditional Flange	
316 SST	03031-0320-0002
Cast C-276	03031-0320-0003
Cast Alloy 400	03031-0320-0004
316 SST - DIN Compliant (option code HJ)	03031-1350-0012
Level Flange, Vertical Mount	
2-in., Class 150, SST	03031-0393-0221
2-in., Class 300, SST	03031-0393-0222
3-in., Class 150, SST	03031-0393-0231
3-in., Class 300, SST	03031-0393-0232
DIN, DN 50, PN 40	03031-0393-1002
DIN, DN 80, PN 40	03031-0393-1012
Flange adapter kits (each kit contains parts for one DP transmitter or two GP/AP transmitters)	Part number
CS bolts, glass-filled PTFE O-Rings	
SST adapters	03031-1300-0002
Cast Alloy C-276 adapters	03031-1300-0003
Alloy 400 adapters	03031-1300-0004
Nickel-plated carbon steel adapters	03031-1300-0005
SST bolts, glass-filled PTFE O-Rings	
SST adapters	03031-1300-0012
Cast Alloy C-276 adapters	03031-1300-0013
Alloy 400 adapters	03031-1300-0014
Nickel-plated carbon steel adapters	03031-1300-0015
CS bolts, graphite-filled PTFE O-Rings	
SST adapters	03031-1300-0102
Cast Alloy C-276 adapters	03031-1300-0103
Alloy 400 adapters	03031-1300-0104
Nickel-plated carbon steel adapters	03031-1300-0105
SST bolts, graphite-filled PTFE O-Rings	
SST adapters	03031-1300-0112
Cast Alloy C-276 adapters	03031-1300-0113
Alloy 400 adapters	03031-1300-0114
Nickel-plated carbon steel adapters	03031-1300-0115
Flange adapters	
1/2–14 NPT adapters	
316 SST	02024-0069-0002
Cast C-276	02024-0069-0003

Cast Alloy 400	02024-0069-0004
Nickel-plated carbon steel	02024-0069-0005
Socket weld adapters	
316 SST	02024-0069-1002
Cast C-276	02024-0069-1003
Cast Alloy 400	02024-0069-1004
O-ring packages (package of 12)	Part number
Electronics housing, cover	03031-0232-0001
Electronics housing, module	03031-0233-0001
Process flange, glass-filled PTFE (White)	03031-0234-0001
Process flange, graphite-filled PTFE (Black)	03031-0234-0002
Process flange for Rosemount 3051H, PTFE (White)	02051-0167-0001
Flange adapter, glass-filled PTFE (Light Brown)	03031-0242-0001
Flange adapter, graphite-filled PTFE (Black)	03031-0242-0002
Bolt kits	
Coplanar flange	
Flange bolt kit (44 mm [1.75-in.]) (set of 4)	
Carbon steel	03031-0312-0001
316 SST	03031-0312-0002
ASTM A 193, Grade B7M	03031-0312-0003
Alloy K-500	03031-0312-0004
Flange/adapter bolt kit (73 mm [2.88 in.]) (set of 4)	
Carbon steel	03031-0306-0001
316 SST	03031-0306-0002
ASTM A 193, Grade B7M	03031-0306-0003
Alloy K-500	03031-0306-0004
Traditional flange	
Differential flange/adapter bolt kit (44 mm [1.75 in.]) (set of 8)	
Carbon steel	03031-0307-0001
316 SST	03031-0307-0002
ASTM A 193, Grade B7M	03031-0307-0003
Alloy K-500	03031-0307-0004
Gage/absolute flange/adapter bolt kit (44 mm [1.75 in.]) (set of 6)	
Carbon steel	03031-0307-1001
316 SST	03031-0307-1002
ASTM A 193, Grade B7M	03031-0307-1003
Alloy K-500	03031-0307-1004

Conventional manifold/traditional flange bolts	
Carbon steel	Use bolts supplied with manifold
316 SST	Use bolts supplied with manifold
Level Flange, Vertical Mount Bolt Kit (Set of 4)	
Carbon steel	03031-0395-0001
316 SST	03031-0395-0002
Rosemount 3051H process flange bolt kit (Set of 4)	
Carbon steel	02051-0164-0001
316 SST	02051-0164-0002
Drain/vent valve kits (each kit contains parts for one transmitter)	Part number
Differential drain/vent kits	
316 SST stem and seat kit	01151-0028-0022
Alloy C-276 stem and seat kit	01151-0028-0023
Alloy K-500 stem and Alloy 400 seat kit	01151-0028-0024
316 SST ceramic ball drain/vent kit	03031-0378-0022
Alloy C-276 ceramic ball drain/vent kit	03031-0378-0023
Alloy 400/K-500 ceramic ball drain/vent kit	03031-0378-0024
Gage/absolute drain/vent kits	
316 SST stem and seat kit	01151-0028-0012
Alloy C-276 stem and seat kit	01151-0028-0013
Alloy K-500 stem and Alloy 400 seat kit	01151-0028-0014
316 SST ceramic ball drain/vent kit	03031-0378-0012
Alloy C-276 ceramic ball drain/vent kit	03031-0378-0013
Alloy 400/K-500 ceramic ball drain/vent kit	03031-0378-0014
Mounting brackets	
Rosemount 3051C and 3051L Coplanar flange bracket kit	
B4 bracket, SST, 2-in. pipe mount, SST bolts	03031-0189-0003
Rosemount 3051T Inline bracket kit	
B4 bracket, SST, 2-in. pipe mount, SST bolts	03031-0189-0004
Rosemount 3051C traditional flange bracket kits	
B1 bracket, 2-in. pipe mount, CS bolts	03031-0313-0001
B2 bracket, panel mount, CS bolts	03031-0313-0002
B3 flat bracket, 2-in. pipe mount, CS bolts	03031-0313-0003
B7 (B1 bracket, SST bolts)	03031-0313-0007
B8 (B2 bracket, SST bolts)	03031-0313-0008
B9 (B3 bracket, SST bolts)	03031-0313-0009
BA (SST B1 bracket, SST bolts)	03031-0313-0011
BC (SST B3 bracket, SST bolts)	03031-0313-0013

Rosemount 3051H bracket kits	
B5 universal bracket, 2-in. pipe and panel mount, CS bolts	03051-1081-0001
B6 universal bracket, 2-in. pipe and panel mount, SST bolts	03051-1081-0002
FOUNDATION Fieldbus upgrade kit	
Aluminum Housing	03031-0198-0001
316 SST Housing	03031-0198-0002

Figure A-16. Spare Parts Diagram

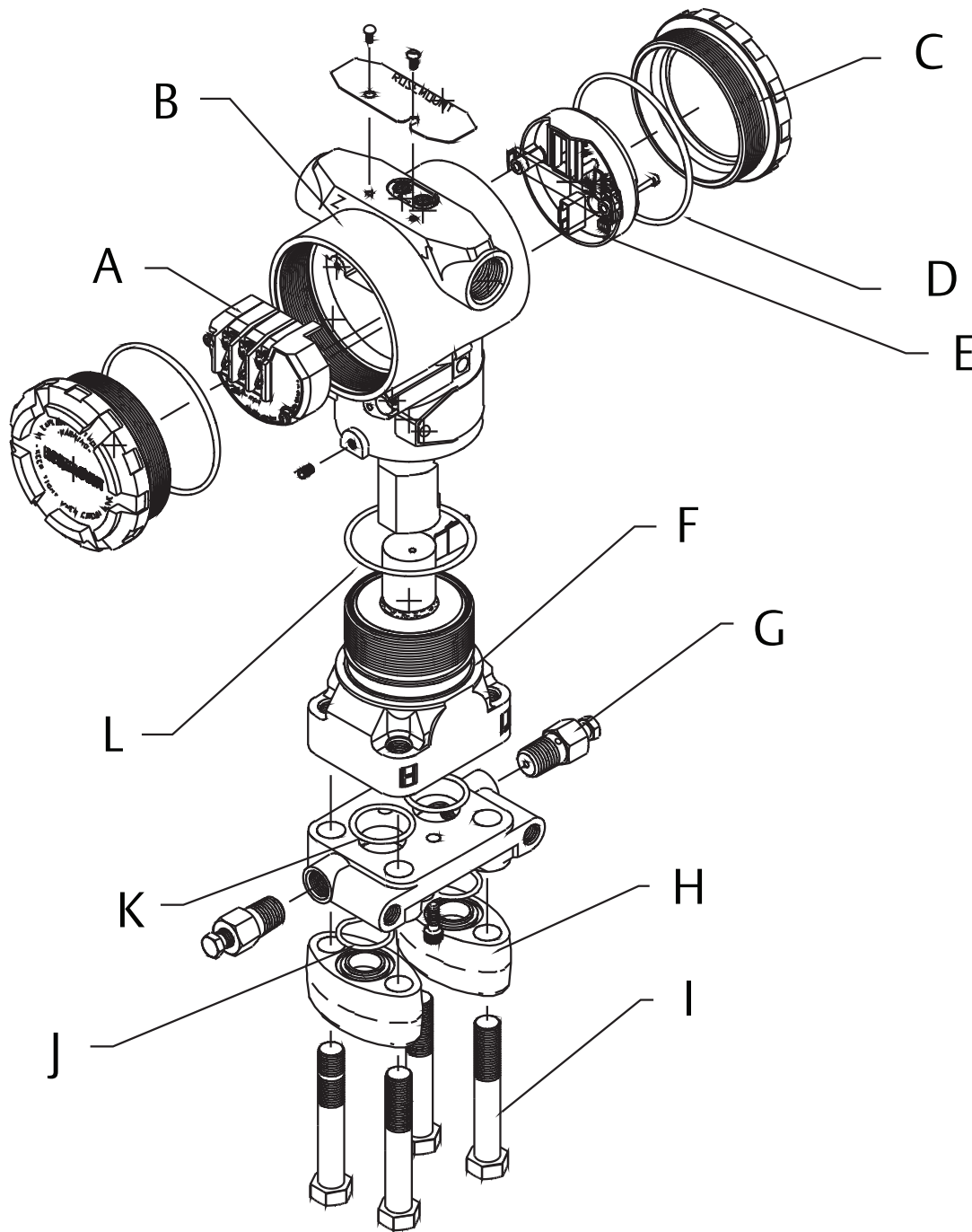

- | | |
|-------------------------------------|--------------------------------------|
| A. Terminal block | G. Drain/vent valve |
| B. Electronics housing | H. Flange adapter |
| C. Housing cover | I. Flange adapter bolts |
| D. Electronics housing cover O-ring | J. Flange adapter O-ring |
| E. Electronics board | K. Process O-ring |
| F. Sensor module | L. Electronics housing module O-ring |

Appendix B Product Certifications

Rev 1.7

European directive information	page 145
Ordinary location certification	page 145
Approval drawing	page 153

B.1 European directive information

A copy of the EU Declaration of Conformity can be found at the end of the Quick Start Guide. The most recent revision of the EU Declaration of Conformity can be found at Emerson.com/Rosemount.

B.2 Ordinary location certification

As standard, the transmitter has been examined and tested to determine that the design meets the basic electrical, mechanical, and fire protection requirements by a nationally recognized test laboratory (NRTL) as accredited by the Federal Occupational Safety and Health Administration (OSHA).

B.3 North America

- E5** USA Explosionproof (XP) and Dust-Ignitionproof (DIP) Range 1-5
 Certificate: OT2H0.AE
 Standards: FM Class 3600 - 2011, FM Class 3615 - 2006, FM Class 3810 - 2005, ANSI/NEMA 250 - 2003
 Markings: XP CL I, DIV 1, GP B, C, D; DIP CL II, DIV 1, GP E, F, G; CL III; T5(-50 °C ≤ T_a ≤ +85 °C); Factory Sealed; Type 4X
- Range 6
 Certificate: 1053834
 Standards: ANSI/ISA 12.27.01-2003, CSA Std. C22.2 No. 30 -M1986, CSA Std. C22.2 No.142-M1987, CSA Std. C22.2 No. 213 - M1987

Markings: XP Class I, Division 1, Groups B, C and D, T5, (-50 °C ≤ T_a ≤ 85°C) Suitable for Class I, Zone 1, Group I IB+H2, T5; DIP Class II and Class III, Division 1, Groups E, F and G, T5, (-50 °C ≤ T_a ≤ 85°C); Type 4X; Factory Sealed; Single Seal (See drawing 03031-1053)

- I5** USA Intrinsic Safety (IS) and Nonincendive (NI) Range 1-5
 Certificate: FM16US0120X
 Standards: FM Class 3600 - 2011, FM Class 3610 - 2010, FM Class 3611 - 2004, FM Class 3810 - 2005, ANSI/NEMA 250 - 2008
 Markings: IS CL I, DIV 1, GP A, B, C, D; CL II, DIV 1, GP E, F, G; Class III; DIV 1 when connected per Rosemount drawing 03031-1019; NI CL 1, DIV 2, GP A, B, C, D; T4(-50 °C ≤ T_a ≤ +70 °C) [HART], T5(-50 °C ≤ T_a ≤ +40 °C) [HART]; T4(-50 °C ≤ T_a ≤ +60 °C) [Fieldbus/PROFIBUS]; Type 4x

Special Conditions for Safe Use (X):

1. The Rosemount 3051 Transmitter housing contains aluminum and is considered a potential risk of ignition by impact or friction. Care must be taken into account during installation and use to prevent impact and friction.
2. The Rosemount 3051 Transmitter with the transient terminal block (Option code T1) will not pass the 500Vrms dielectric strength test and this must be taken into account during installation.

Range 6
 Certificate: 1053834
 Standards: ANSI/ISA 12.27.01-2003, CSA Std. C22.2 No.142-M1987, CSA Std. C22.2 No.157-92

Markings: IS Class I, II, III, Division 1 Groups A, B, C, D, E, F, and G when connected in accordance with Rosemount drawing 03031-1024, Suitable for Class I, Zone 0 Group IIC; Class I, Division 2, Groups A, B, C and D; NIFW; Suitable for Class I Zone 2, Group IIC; HART: T4 ($-60\text{ }^{\circ}\text{C} \leq T_a \leq 70\text{ }^{\circ}\text{C}$); T5 ($-60\text{ }^{\circ}\text{C} \leq T_a \leq 40\text{ }^{\circ}\text{C}$) Fieldbus/PROFIBUS: T4 ($-60\text{ }^{\circ}\text{C} \leq T_a \leq 60\text{ }^{\circ}\text{C}$) Type 4X; Factory Sealed; Single Seal (See drawing 03031-1053)

IE USA FISCO
Range 1-5
Certificate: FM16US0120X
Standards: FM Class 3600 - 2011, FM Class 3610 - 2010, FM Class 3611 - 2004, FM Class 3810 - 2005
Markings: IS CLI, DIV 1, GPA, B, C, D when connected per Rosemount drawing 03031-1019 ($-50\text{ }^{\circ}\text{C} \leq T_a \leq +60\text{ }^{\circ}\text{C}$); Type 4x

Special Conditions for Safe Use (X):

1. The Rosemount 3051 Transmitter housing contains aluminum and is considered a potential risk of ignition by impact or friction. Care must be taken into account during installation and use to prevent impact and friction.
2. The Rosemount 3051 Transmitter with the transient terminal block (option code T1) will not pass the 500 Vrms dielectric strength test and this must be taken into account during installation.

Range 6
Certificate: 1053834
Standards: ANSI/ISA 12.27.01-2003, CSA Std. C22.2 No.142-M1987, CSA Std. C22.2 No.157-92
Markings: IS Class I, Division 1 Groups A, B, C, D, T4 ($-60\text{ }^{\circ}\text{C} \leq T_a \leq +60\text{ }^{\circ}\text{C}$) when connected in accordance with Rosemount drawing 03031-1024, Suitable for Class I, Zone 0 Group IIC; Type 4X; Factory Sealed; Single Seal (See drawing 03031-1053)

C6 Canada Explosionproof, Dust-Ignitionproof, Intrinsic Safety and Nonincendive
Certificate: 1053834
Standards: ANSI/ISA 12.27.01-2003, CSA Std. C22.2 No. 30 -M1986, CSA Std. C22.2 No.142-M1987, CSA Std. C22.2 No.157-92, CSA Std. C22.2 No. 213 - M1987

Markings: Explosionproof for Class I, Division 1, Groups B, C and D; Suitable for Class I, Zone 1, Group IIB+H2, T5 ($-50\text{ }^{\circ}\text{C} \leq T_a \leq 85\text{ }^{\circ}\text{C}$); Dust-Ignitionproof Class II, III, Division 1, Groups E, F, G, T5 ($-50\text{ }^{\circ}\text{C} \leq T_a \leq 85\text{ }^{\circ}\text{C}$); Class III Division 1; Intrinsically Safe Class I, Division 1 Groups A, B, C, D when connected in accordance with Rosemount drawing 03031-1024, Temperature Code T4; Suitable for Class I, Zone 0; Class I Division 2 Groups A, B, C and D, T5 ($-50\text{ }^{\circ}\text{C} \leq T_a \leq 85\text{ }^{\circ}\text{C}$); Suitable for Class I Zone 2, Group IIC; Type 4X; Factory Sealed; Single Seal (See drawing 03031-1053)

E6 Canada Explosionproof, Dust-Ignitionproof and Division 2
Certificate: 1053834
Standards: ANSI/ISA 12.27.01-2003, CSA Std. C22.2 No. 30 -M1986, CSA Std. C22.2 No.142-M1987, CSA Std. C22.2 No. 213 - M1987
Markings: Explosionproof Class I, Division 1, Groups B, C and D; Suitable for Class I, Zone 1, Group IIB+H2, T5($-50\text{ }^{\circ}\text{C} \leq T_a \leq 85\text{ }^{\circ}\text{C}$); Dust-Ignitionproof for Class II and Class III, Division 1, Groups E, F and G; T5 ($-50\text{ }^{\circ}\text{C} \leq T_a \leq 85\text{ }^{\circ}\text{C}$); Class I, Division 2, Groups A, B, C and D; T5 ($-50\text{ }^{\circ}\text{C} \leq T_a \leq 85\text{ }^{\circ}\text{C}$); Suitable for Class I Zone 2, Group IIC; Type 4X; Factory Sealed; Single Seal (See drawing 03031-1053)

B.4 Europe



E8 ATEX Flameproof and Dust
Certificate: KEMA00ATEX2013X; Baseefa11ATEX0275X
Standards: EN60079-0:2012 + A11:2013, EN60079-1:2014, EN60079-26:2015, EN60079-31:2009
Markings:  II 1/2 G Ex db IIC T6...T4 Ga/Gb, T6 ($-60\text{ }^{\circ}\text{C} \leq T_a \leq +70\text{ }^{\circ}\text{C}$), T4/T5 ($-60\text{ }^{\circ}\text{C} \leq T_a \leq +80\text{ }^{\circ}\text{C}$);  II 1 D Ex ta IIIC T95 °C T₅₀₀ 105 °C Da ($-20\text{ }^{\circ}\text{C} \leq T_a \leq +85\text{ }^{\circ}\text{C}$)

Table B-1. Process Temperature

Temperature class	Process temperature
T6	-60 °C to +65 °C
T5	-60 °C to +80 °C
T4	-60 °C to +120 °C

Special Conditions for Safe Use (X):



1. This device contains a thin wall diaphragm. Installation, maintenance and use shall take into account the environmental conditions to which the diaphragm will be subjected. The manufacturer's instructions for installation and maintenance shall be followed in detail to assure safety during its expected lifetime.
 2. Flameproof joints are not intended for repair.
 3. Non-standard paint options may cause risk from electrostatic discharge. Avoid installations that could cause electrostatic build-up on painted surfaces, and only clean the painted surfaces with a damp cloth. If paint is ordered through a special option code, contact the manufacturer for more information.
 4. Some variants of the equipment have reduced markings on the nameplate. Refer to the Certificate for full equipment marking.
- I1** ATEX Intrinsic Safety and Dust
 Certificate: BAS97ATEX1089X; Baseefa11ATEX0275X
 Standards: EN60079-0:2012, EN60079-11:2012, EN60079-31:2009
 Markings: HART:  II 1 G Ex ia IIC T5/T4 Ga, T5 (-60 °C ≤ T_a ≤ +40 °C), T4(-60 °C ≤ T_a ≤ +70 °C)
 Fieldbus/PROFIBUS:  II 1 G Ex ia IIC Ga T4(-60 °C ≤ T_a ≤ +60 °C)
 DUST:  II 1 D Ex ta IIIC T95 °C T₅₀₀ 105 °C Da (-20 °C ≤ T_a ≤ +85 °C)

Table B-2. Input Parameters

Parameter	HART	Fieldbus/PROFIBUS
Voltage U _i	30 V	30 V
Current I _i	200 mA	300 mA
Power P _i	0.9 W	1.3 W
Capacitance C _i	0.012 μF	0 μF
Inductance L _i	0 mH	0 mH

Special Conditions for Safe Use (X):

1. The apparatus is not capable of withstanding the 500 V insulation test required by clause 6.3.12 of EN60079-11:2012. This must be taken into account when installing the apparatus.
2. The enclosure may be made of aluminum alloy and given a protective polyurethane paint finish; however care should be taken to protect it from impact or abrasion if located in Zone 0.
3. Some variants of the equipment have reduced markings on the nameplate. Refer to the Certificate for full equipment marking.

IA ATEX FISCO

Certificate: BAS97ATEX1089X
 Standards: EN60079-0:2012, EN60079-11:2009
 Markings:  II 1 G Ex ia IIC T4 Ga (-60 °C ≤ T_a ≤ +60 °C)



Table B-3. Input Parameters

Parameters	FISCO
Voltage U _i	17.5 V
Current I _i	380 mA
Power P _i	5.32 W
Capacitance C _i	<5 nF
Inductance L _i	<10 μH

Special Conditions for Safe Use (X):

1. The apparatus is not capable of withstanding the 500 V insulation test required by clause 6.3.12 of EN60079-11:2012. This must be taken into account when installing the apparatus.
2. The enclosure may be made of aluminum alloy and given a protective polyurethane paint finish; however care should be taken to protect it from impact or abrasion if located in Zone 0.

N1 ATEX Type n and Dust

Certificate: BAS00ATEX3105X; Baseefa11ATEX0275X
 Standards: EN60079-0:2012, EN60079-15:2010, EN60079-31:2009
 Markings:  II 3 G Ex nA IIC T5 Gc (-40 °C ≤ T_a ≤ +70 °C);  II 1 D Ex ta IIIC T95 °C T₅₀₀ 105 °C Da (-20 °C ≤ T_a ≤ +85 °C)

Special Conditions for Safe Use (X):

1. This apparatus is not capable of withstanding the 500 V insulation test that is required by clause 6.8.1 of EN60079-15. This must be taken into account when installing the apparatus.
2. Some variants of the equipment have reduced markings on the nameplate. Refer to the Certificate for full equipment marking.

B.5 International

- E7** IECEx Flameproof and Dust
 Certificate: IECEx KEM 09.0034X; IECEx BAS 10.0034X
 Standards: IEC60079-0:2011, IEC60079-1:2014-06, IEC60079-26:2014-10, IEC60079-31:2008
 Markings: Ex db IIC T6...T4 Ga/Gb, T6(-60 °C ≤ T_a ≤ +70 °C), T4/T5(-60 °C ≤ T_a ≤ +80 °C);
 Ex ta IIIC T95 °C T₅₀₀ 105 °C Da (-20 °C ≤ T_a ≤ +85 °C)

Table B-4. Process Temperature

Temperature class	Process temperature
T6	-60 °C to +70 °C
T5	-60 °C to +80 °C
T4	-60 °C to +80 °C

Special Conditions for Safe Use (X):

1. This device contains a thin wall diaphragm. Installation, maintenance and use shall take into account the environmental conditions to which the diaphragm will be subjected. The manufacturer's instructions for installation and maintenance shall be followed in detail to assure safety during its expected lifetime.
2. Flameproof joints are not intended for repair.
3. Non-standard paint options may cause risk from electrostatic discharge. Avoid installations that could cause electrostatic build-up on painted surfaces, and only clean the painted surfaces with a damp cloth. If paint is ordered through a special option code, contact the manufacturer for more information.
4. Some variants of the equipment have reduced markings on the nameplate. Refer to the Certificate for full equipment marking.

- I7** IECEx Intrinsic Safety
 Certificate: IECEx BAS 09.0076X
 Standards: IEC60079-0:2011, IEC60079-11:2011
 Markings: HART: Ex ia IIC T5/T4 Ga, T5(-60 °C ≤ T_a ≤ +40 °C), T4(-60 °C ≤ T_a ≤ +70 °C)
 Fieldbus/PROFIBUS: Ex ia IIC T4(-60 °C ≤ T_a ≤ +60 °C)

Table B-5. Input Parameters

Parameter	HART	Fieldbus/PROFIBUS
Voltage U _i	30 V	30 V
Current I _i	200 mA	300 mA
Power P _i	0.9 W	1.3 W
Capacitance C _i	0.012 μF	0 μF
Inductance L _i	0 mH	0 mH

Special Conditions for Safe Use (X):

1. If the apparatus is fitted with an optional 90V transient suppressor, it is not capable of withstanding the 500 V insulation test required by clause 6.3.12 of IEC60079-11. This must be taken into account when installing the apparatus.
2. The enclosure may be made of aluminum alloy and given a protective polyurethane paint finish; however, care should be taken to protect it from impact or abrasion if located in Zone 0.

IECEx Mining (Special A0259)
 Certificate: IECEx TSA 14.0001X
 Standards: IEC60079-0:2011, IEC60079-11:2011
 Markings: Ex ia I Ma (-60 °C ≤ T_a ≤ +70 °C)

Parameter	HART	Fieldbus/PROFIBUS	FISCO
Voltage U _i	30 V	30 V	17.5 V
Current I _i	200 mA	300 mA	380 mA
Power P _i	0.9 W	1.3 W	5.32 W
Capacitance C _i	0.012 μF	0 μF	<5 nF
Inductance L _i	0 mH	0 mH	<10 μH

Special Conditions for Safe Use (X):

1. If the apparatus is fitted with an optional 90V transient suppressor, it is not capable of withstanding the 500 V insulation test required by IEC60079-11. This must be taken into account when installing the apparatus.
2. It is a condition of safe use that the above input parameters shall be taken into account during installation.
3. It is a condition of manufacture that only the apparatus fitted with housing, covers and sensor module housing made out of stainless steel are used in Group I applications.

N7 IECEx Type n

Certificate: IECEx BAS 09.0077X
 Standards: IEC60079-0:2011, IEC60079-15:2010
 Markings: Ex nA IIC T5 Gc (-40 °C ≤ T_a ≤ +70 °C)

Special Conditions for Safe Use (X):

1. The apparatus is not capable of withstanding the 500 V insulation test required by IEC60079-15. This must be taken into account when installing the apparatus.

B.6 Brazil

E2 INMETRO Flameproof

Certificate: UL-BR 13.0643X
 Standards: ABNT NBR IEC60079-0:2008 + Errata 1:2011, ABNT NBR IEC60079-1:2009 + Errata 1:2011, ABNT NBR IEC60079-26:2008 + Errata 1:2008
 Markings: Ex db IIC T6...T4 Ga/Gb, T6(-60 °C ≤ T_a ≤ +70 °C), T4/T5(-60 °C ≤ T_a ≤ +80 °C)

Special Conditions for Safe Use (X):

1. This device contains a thin wall diaphragm less than 1 mm thickness that forms a boundary between zone 0 (process connection) and zone 1 (all other parts of the equipment). The model code and datasheet are to be consulted for details of the diaphragm material. Installation, maintenance and use shall take into account the environmental conditions to which the diaphragm will be subjected. The manufacturer's instructions for installation and maintenance shall be followed in detail to assure safety during its expected lifetime.
2. Flameproof joints are not intended for repair.

3. Non-standard paint options may cause risk from electrostatic discharge. Avoid installations that could cause electrostatic build-up on painted surfaces, and only clean the painted surfaces with a damp cloth. If paint is ordered through a special option code, contact the manufacturer for more information.

I2 INMETRO Intrinsic Safety

Certificate: UL-BR 13.0584X
 Standards: ABNT NBR IEC60079-0:2008 + Errata 1:2011, ABNT NBR IEC60079-11:2009
 Markings: HART: Ex ia IIC T5/T4 Ga, T5(-60 °C ≤ T_a ≤ +40 °C), T4(-60 °C ≤ T_a ≤ +70 °C)
 Fieldbus/PROFIBUS: Ex ia IIC T4 Ga (-60 °C ≤ T_a ≤ +60 °C)

Table B-6. Input Parameters

Parameter	HART	Fieldbus/PROFIBUS
Voltage U_i	30 V	30 V
Current I_i	200 mA	300 mA
Power P_i	0.9 W	1.3 W
Capacitance C_i	0.012 μF	0 μF
Inductance L_i	0 mH	0 mH

Special Conditions for Safe Use (X):

1. If the equipment is fitted with an optional 90V transient suppressor, it is not capable of withstanding the 500 V insulation test required by ABNT NBR IRC 60079-11. This must be taken into account when installing the equipment.
2. The enclosure may be made of aluminum alloy and given a protective polyurethane paint finish; however, care should be taken to protect it from impact or abrasion if located in Zone 0.

IB INMETRO FISCO

Certificate: UL-BR 13.0584X
 Standards: ABNT NBR IEC60079-0:2008 + Errata 1:2011, ABNT NBR IEC60079-11:2009
 Markings: Ex ia IIC T4 Ga (-60 °C ≤ T_a ≤ +60 °C)

Table B-7. Input Parameters

Parameters	FISCO
Voltage U_i	17.5 V
Current I_i	380 mA
Power P_i	5.32 W
Capacitance C_i	<5 nF
Inductance L_i	<10 μ H

Special Conditions for Safe Use (X):

1. If the equipment is fitted with an optional 90V transient suppressor, it is not capable of withstanding the 500 V insulation test required by ABNT NBR IEC 60079-11. This must be taken into account when installing the equipment.
2. The enclosure may be made of aluminum alloy and given a protective polyurethane paint finish; however, care should be taken to protect it from impact or abrasion if located in Zone 0.

B.7 China

E3 China Flameproof

Certificate: GYJ14.1041X; GYJ15.1368X [Flowmeters]
Standards: GB12476-2000; GB3836.1-2010, GB3836.2-2010, GB3836.20-2010
Markings: Ex d IIC T6/T5 Ga/Gb, T6($-50\text{ }^\circ\text{C} \leq T_a \leq +65\text{ }^\circ\text{C}$), T5($-50\text{ }^\circ\text{C} \leq T_a \leq +80\text{ }^\circ\text{C}$)

Special Conditions for Safe Use (X):

1. The relation between ambient temperature arrange and temperature class is as follows:

Ta	Temperature Class
$-50\text{ }^\circ\text{C} \sim +80\text{ }^\circ\text{C}$	T5
$-50\text{ }^\circ\text{C} \sim +65\text{ }^\circ\text{C}$	T6

When used in a combustible dust environment, the maximum ambient temperature is 80 °C.

2. The earth connection facility in the enclosure should be connected reliably.

3. Cable entry certified by notified body with type of protection Ex d IIC in accordance with GB3836.1-2000 and GB3836.2-2000, should be applied when installed in a hazardous location. When used in combustible dust environment, cable entry in accordance with IP66 or higher level should be applied.
 4. Obey the warning “Keep tight when the circuit is alive.”
 5. End users are not permitted to change any internal components.
 6. During installation, use and maintenance of this product, observe the following standards: GB3836.13-1997, GB3836.15-2000, GB3836.16-2006, GB50257-1996, GB12476.2-2006, GB15577-2007
- I3 China Intrinsic Safety**
Certificate: GYJ13.1362X; GYJ15.1367X [Flowmeters]
Standards: GB3836.1-2010, GB3836.4-2010, GB3836.20-2010, GB12476.1-2000
Markings: Ex ia IIC Ga T4/T5

Special Conditions for Safe Use (X):

1. Symbol “X” is used to denote specific conditions of use:
 - a. If the apparatus is fitted with an optional 90 V transient suppressor, it is not capable of withstanding the 500 V insulation test for one minute. This must be taken into account when installing the apparatus.
 - b. The enclosure may be made of aluminum alloy and given a protective polyurethane paint finish; however, care should be taken to protect it from impact or abrasion if located in Zone 0.
2. The relation between T code and ambient temperature range is:

Model	T Code	Temperature Range
HART	T5	$-60\text{ }^\circ\text{C} \leq T_a \leq +40\text{ }^\circ\text{C}$
HART	T4	$-60\text{ }^\circ\text{C} \leq T_a \leq +70\text{ }^\circ\text{C}$
Fieldbus/PROFIBUS/ FISCO	T4	$-60\text{ }^\circ\text{C} \leq T_a \leq +60\text{ }^\circ\text{C}$

3. Intrinsically Safe parameters:

Parameter	HART	Fieldbus/ PROFIBUS	FISCO
Voltage U_i	30 V	30 V	17.5 V
Current I_i	200 mA	300 mA	380 mA
Power P_i	0.9 W	1.3 W	5.32 W
Capacitance C_i	0.012 μ F	0 μ F	<5 nF
Inductance L_i	0 mH	0 mH	<10 μ H

Note

FISCO parameters apply to both Group IIC and IIB.

[For Flowmeters] When Rosemount 644 Temperature Transmitter is used, the Rosemount 644 Transmitter should be used with Ex-certified associated apparatus to establish explosion protection system that can be used in explosive gas atmospheres. Wiring and terminals should comply with the instruction manual of both Rosemount 644 Transmitter and associated apparatus. The cables between Rosemount 644 Transmitter and associated apparatus should be shielded cables (the cables must have insulated shield). The shielded cable has to be grounded reliably in a non-hazardous area.

- Transmitters comply with the requirements for FISCO field devices specified in IEC60079-27:2008. For the connection of an intrinsically safe circuit in accordance with FISCO Model, FISCO parameters are listed in the table above.
- The product should be used with Ex-certified associated apparatus to establish explosion protection system that can be used in explosive gas atmospheres. Wiring and terminals should comply with the instruction manual of the product and associated apparatus.
- The cables between this product and associated apparatus should be shielded cables (the cables must have insulated shield). The shielded cable has to be grounded reliably in a non-hazardous area.
- End users are not permitted to change any intern components but to settle the problem in conjunction with the manufacturer to avoid damage to the product.
- During installation, use and maintenance of this product, observe the following standards: GB3836.13-1997, GB3836.15-2000, GB3836.16-2006, GB50257-1996, GB12476.2-2006, GB15577-2007

N3 China Type n

Certificate: GYJ15.1105X
 Standards: GB3836.1-2010, GB3836.8-2003
 Markings: Ex nA nL IIC T5 Gc (-40 °C ≤ T_a ≤ +70 °C)

Special Condition for Safe Use (X):

- Symbol “X” is used to denote specific conditions of use: The apparatus is not capable of withstanding the 500 V test to earth for one minute. The must be taken into consideration during installation.

B.8 Japan

E4 Japan Flameproof

Certificate: TC20577, TC20578, TC20583, TC20584 [HART]; TC20579, TC20580, TC20581, TC20582 [Fieldbus]
 Markings: Ex d IIC T5

B.9 Technical Regulations Customs Union (EAC)

EM EAC Flameproof

Certificate: RU C-US.GB05.B.01197
 Markings: Ga/Gb Ex d IIC T5/T6 X, T5(-60 °C ≤ T_a ≤ +80°C), T6(-60 °C ≤ T_a ≤ +65 °C)

Special Condition for Safe Use (X):

- See certificate for special conditions.

IM EAC Intrinsically Safe

Certificate: RU C-US.GB05.B.01197
 Markings: HART: 0Ex ia IIC T4/T5 Ga X, T4(-60 °C ≤ T_a ≤ +70 °C), T5(-60 °C ≤ T_a ≤ +40 °C)
 Fieldbus/PROFIBUS: 0Ex ia IIC T4 Ga X (-60 °C ≤ T_a ≤ +60 °C)

Special Condition for Safe Use (X):

- See certificate for special conditions.

B.10 Combinations

- K2** Combination of E2 and I2
- K5** Combination of E5 and I5
- K6** Combination of C6, E8, and I1
- K7** Combination of E7, I7, and N7
- K8** Combination of E8, I1, and N1
- KB** Combination of E5, I5, and C6
- KD** Combination of E8, I1, E5, I5, and C6
- KM** Combination of EM and IM

B.11 Conduit plugs and adapters

IECEX Flameproof and Increased Safety
Certificate: IECEX FMG 13.0032X
Standards: IEC60079-0:2011, IEC60079-1:2007,
IEC60079-7:2006-2007
Markings: Ex de IIC Gb

ATEX Flameproof and Increased Safety
Certificate: FM13ATEX0076X
Standards: EN60079-0:2012, EN60079-1:2007,
IEC60079-7:2007
Markings:  II 2 G Ex de IIC Gb

Table B-8. Conduit Plug Thread Sizes

Thread	Identification mark
M20 × 1.5	M20
1/2-14 NPT	1/2 NPT

Table B-9. Thread Adapter Thread Sizes

Male Thread	Identification mark
M20 × 1.5 – 6H	M20
1/2-14 NPT	1/2 – 14 NPT
3/4 – 14 NPT	3/4 – 14 NPT
Female Thread	Identification mark
M20 × 1.5 – 6H	M20
1/2-14 NPT	1/2-14 NPT
G1/2	G1/2

Special Conditions for Safe Use (X):

1. When the thread adapter or blanking plug is used with an enclosure in type of protection increased safety “e” the entry thread shall be suitably sealed in order to maintain the ingress protection rating (IP) of the enclosure.
2. The blanking plug shall not be used with an adapter.
3. Blanking Plug and Threaded Adapter shall be either NPT or Metric thread forms. G1/2 thread forms are only acceptable for existing (legacy) equipment installations.

B.12 Additional Certifications

SBS American Bureau of Shipping (ABS) Type Approval
Certificate: 09-HS446883A-5-PDA
Intended Use: Marine & Offshore Applications -
Measurement of either gauge or
absolute pressure for liquid, gas and
vapor.

SBV Bureau Veritas (BV) Type Approval
Certificate: 23155
Requirements: Bureau Veritas Rules for the
Classification of Steel Ships
Application: Class notations: AUT-UMS, AUT-CCS,
AUT-PORT and AUT-IMS; Pressure
transmitter type 3051 cannot be
installed on diesel engines

SDN Det Norske Veritas (DNV) Type Approval
Certificate: TAA000004F
Intended Use: DNV GL Rules for Classification - Ships
and offshore units

Application:

Location Classes	
Temperature	D
Humidity	B
Vibration	A
EMC	B
Enclosure	D

SLL Lloyds Register (LR) Type Approval
Certificate: 11/60002
Application: Environmental categories ENV1,
ENV2, ENV3, and ENV5

C5 Custody Transfer - Measurement Canada Accuracy
Approval
Certificate: AG-0226; AG-0454; AG-0477

B.13 Approval drawing

B.13.1 Factory mutual 03031-1019

CONFIDENTIAL AND PROPRIETARY INFORMATION IS CONTAINED HEREIN AND MUST BE HANDLED ACCORDINGLY	REVISIONS			
	REV	DESCRIPTION	CHG. NO.	APP'D DATE
	AE	ADD 3051G	RTC1019922	J.G. 7/11/05
	AF	ADD FISCO DETAILS	RTC1021913	N.J.H. 7/9/06
	AG	ADD FISCO ENTITY PARAMETERS TO SHT 12	RTC1022876	N.J.H. 10/27/06

ENTITY APPROVALS FOR

3051C	3001C
3051L	3001CL
3051P	3001CH
3051H	3001S
3051CA	3001SL
3051T	3001SH
3051G	

OUTPUT CODE A (4-20 mA HART) I.S. SEE SHEETS 2-5
OUTPUT CODE M (LOW POWER) I.S. SEE SHEETS 6-7
OUTPUT CODE F/W (FIELD BUS) I.S. SEE SHEETS 8-12
ALL OUTPUT CODES NONINCENDIVE SEE SHEET 13

THE ROSEMOUNT TRANSMITTERS LISTED ABOVE ARE F.M. APPROVED AS INTRINSICALLY SAFE WHEN USED IN CIRCUIT WITH F.M. APPROVED BARRIERS WHICH MEET THE ENTITY PARAMETERS LISTED IN THE CLASS I, II, AND III, DIVISION 1 GROUPS INDICATED, TEMP CODE T4. ADDITIONALLY, THE ROSEMOUNT 751 FIELD SIGNAL INDICATOR IS F.M. APPROVED AS INTRINSICALLY SAFE WHEN CONNECTED IN CIRCUIT WITH ROSEMOUNT TRANSMITTERS (FROM ABOVE) AND F.M. APPROVED BARRIERS WHICH MEET THE ENTITY PARAMETERS LISTED FOR CLASS I, II, AND III, DIVISION 1, GROUPS INDICATED, TEMP CODE T4.

TO ASSURE AN INTRINSICALLY SAFE SYSTEM, THE TRANSMITTER AND BARRIER MUST BE WIRED IN ACCORDANCE WITH THE BARRIER MANUFACTURER'S FIELD WIRING INSTRUCTIONS AND THE APPLICABLE CIRCUIT DIAGRAM.

CAD MAINTAINED (MicroStation)

<small>UNLESS OTHERWISE SPECIFIED DIMENSIONS IN INCHES (mm). REMOVE ALL BURRS AND SHARP EDGES. MACHINE SURFACE FINISH 125</small> <small>-TOLERANCE-</small> .X ± .1 [2,5] .XX ± .02 [0,5] .XXX ± .010 [0,25] <small>FRACTIONS</small> ± 1/32 <small>ANGLES</small> ± 2° DO NOT SCALE PRINT	CONTRACT NO.	 ROSEMOUNT® <small>8200 Market Boulevard • Chanhassen, MN 55317 USA</small>	
	DR. MIKE DOBE 03/21/89	TITLE INDEX OF I.S. & NONINCENDIVE F.M. FOR 3051C/L/P/H/T AND 3001C/S	
	CHK'D		
	APP'D. KELLY ORTH 03/22/89	SIZE A	FSCM NO.
APP'D. GOVT.	SCALE N/A	WT.	SHEET 1 OF 13

REVISIONS				
REV	DESCRIPTION	CHG. NO.	APP'D	DATE
AG				

BARRIER PARAMETERS (APPLICABLE TO OUTPUT CODES A & M)
 $P_{max} = 1WATT$

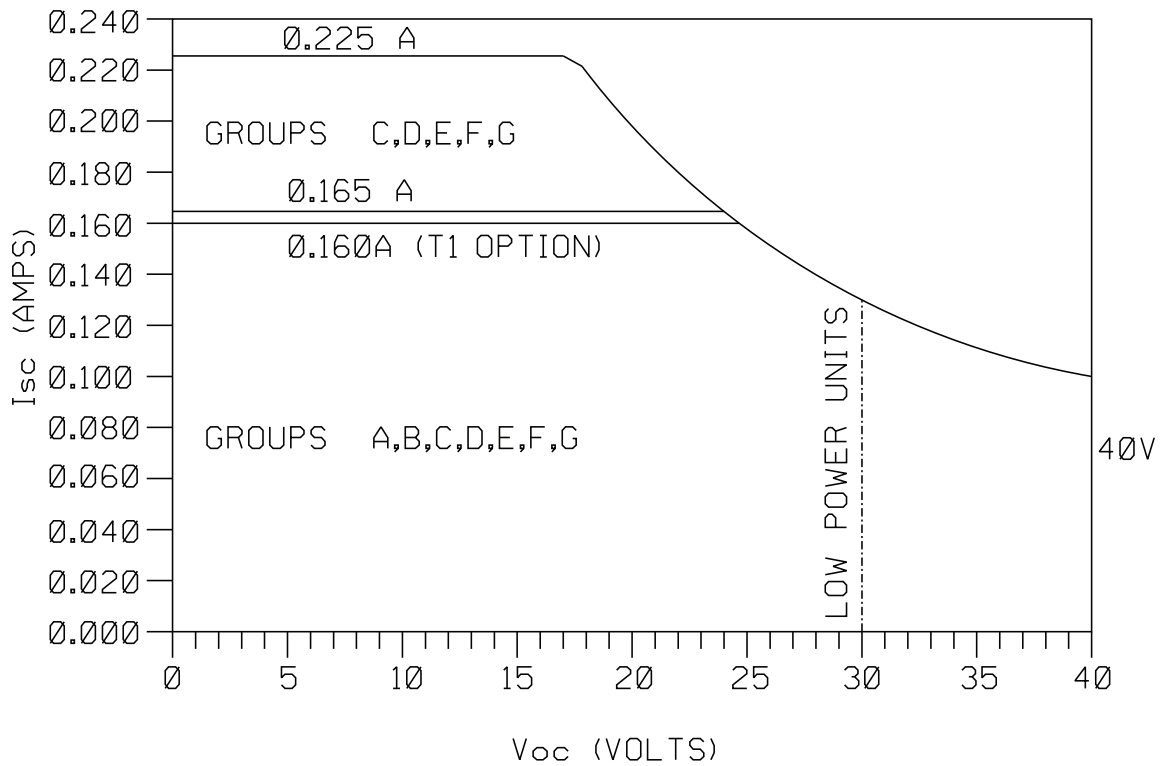

Rosemount Inc.
8200 Market Boulevard
Chanhausen, MN 55317 USA

CAD MAINTAINED (MicroStation)

DR.	MIKE DOBE	SIZE	A	FSCM NO		DWG NO.	03031-1019
ISSUED		SCALE	N/A	WT.		SHEET	2 OF 13

From Rev AC

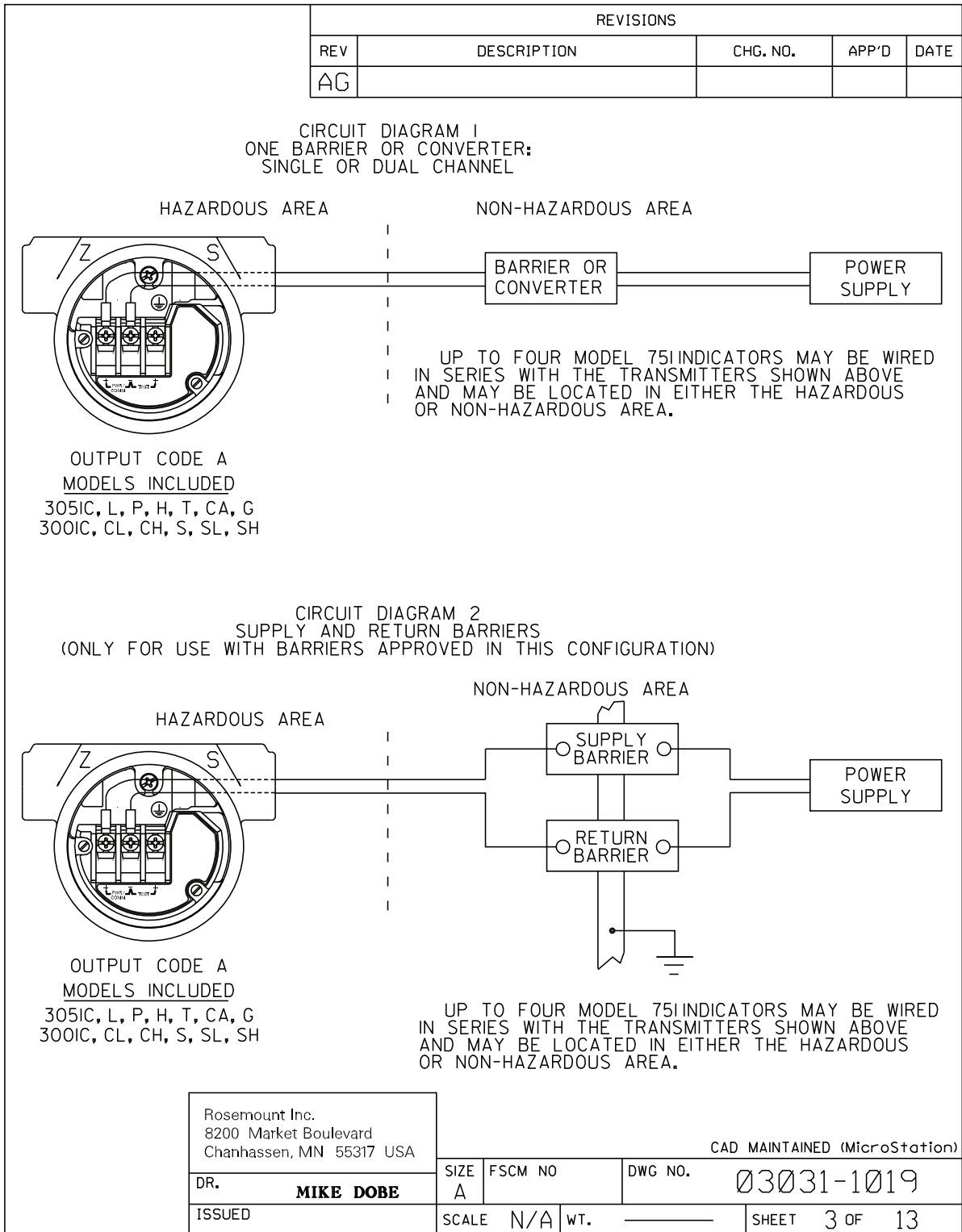

REVISIONS				
REV	DESCRIPTION	CHG. NO.	APP'D	DATE
AG				

ENTITY CONCEPT APPROVALS

THE ENTITY CONCEPT ALLOWS INTERCONNECTION OF INTRINSICALLY SAFE APPARATUS TO ASSOCIATED APPARATUS NOT SPECIFICALLY EXAMINED IN COMBINATION AS A SYSTEM. THE APPROVED VALUES OF MAX. OPEN CIRCUIT VOLTAGE (V_{OC} OR V_t) AND MAX. SHORT CIRCUIT CURRENT (I_{SC} OR I_t) AND MAX. POWER ($V_{OC} \times I_{SC}/4$) OR ($V_t \times I_t/4$), FOR THE ASSOCIATED APPARATUS MUST BE LESS THAN OR EQUAL TO THE MAXIMUM SAFE INPUT VOLTAGE (V_{MAX}), MAXIMUM SAFE INPUT CURRENT (I_{MAX}), AND MAXIMUM SAFE INPUT POWER (P_{MAX}) OF THE INTRINSICALLY SAFE APPARATUS. IN ADDITION, THE APPROVED MAX. ALLOWABLE CONNECTED CAPACITANCE (C_a) OF THE ASSOCIATED APPARATUS MUST BE GREATER THAN THE SUM OF THE INTERCONNECTING CABLE CAPACITANCE AND THE UNPROTECTED INTERNAL CAPACITANCE (C_i) OF THE INTRINSICALLY SAFE APPARATUS, AND THE APPROVED MAX. ALLOWABLE CONNECTED INDUCTANCE (L_a) OF THE ASSOCIATED APPARATUS MUST BE GREATER THAN THE SUM OF THE INTERCONNECTING CABLE INDUCTANCE AND THE UNPROTECTED INTERNAL INDUCTANCE (L_i) OF THE INTRINSICALLY SAFE APPARATUS.

FOR OUTPUT CODE A NOTE: ENTITY PARAMETERS LISTED APPLY ONLY TO ASSOCIATED APPARATUS WITH LINEAR OUTPUT.

CLASS I, DIV. 1, GROUPS A AND B

$V_{MAX} = 40V$	V_t OR V_{OC} IS LESS THAN OR EQUAL TO 40V
$I_{MAX} = 165mA$	I_t OR I_{SC} IS LESS THAN OR EQUAL TO 165mA
$P_{MAX} = 1 \text{ WATT}$	$(\frac{V_t \times I_t}{4})$ OR $(\frac{V_{oc} \times I_{sc}}{4})$ IS LESS THAN OR EQUAL TO 1 WATT
$C_i = .01\mu f$	C_a IS GREATER THAN $.01\mu f$
$L_i = 10\mu H$	L_a IS GREATER THAN $10\mu H$

* FOR T1 OPTION:

$I_{MAX} = 160mA$	I_t OR I_{SC} IS LESS THAN OR EQUAL TO 160mA
$L_i = 1.05mH$	L_a IS GREATER THAN $1.05mH$

CLASS I, DIV. 1, GROUPS C AND D

$V_{MAX} = 40V$	V_t OR V_{OC} IS LESS THAN OR EQUAL TO 40V
$I_{MAX} = 225mA$	I_t OR I_{SC} IS LESS THAN OR EQUAL TO 225mA
$P_{MAX} = 1 \text{ WATT}$	$(\frac{V_t \times I_t}{4})$ OR $(\frac{V_{oc} \times I_{sc}}{4})$ IS LESS THAN OR EQUAL TO 1 WATT
$C_i = .01\mu f$	C_a IS GREATER THAN $.01\mu f$
$L_i = 10\mu H$	L_a IS GREATER THAN $10\mu H$

* FOR T1 OPTION:

$L_i = 1.05mH$	L_a IS GREATER THAN $1.05mH$
----------------	--------------------------------

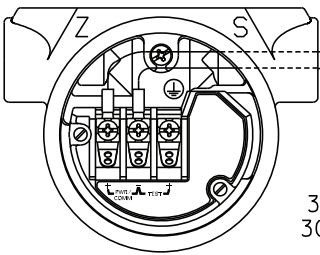

HAZARDOUS AREA | NON-HAZARDOUS AREA

ASSOCIATED APPARATUS

(SEE SHEET 3)

OUTPUT CODE A
MODELS INCLUDED
305IC, L, P, H, T, CA, G
300IC, CL, CH, S, SL, SH

Rosemount Inc. 8200 Market Boulevard Chanhassen, MN 55317 USA		CAD MAINTAINED (MicroStation)	
DR. MIKE DOBE	SIZE A	FSCM NO	DWG NO. 03031-1019
ISSUED	SCALE N/A	WT. _____	SHEET 4 OF 13

REVISIONS				
REV	DESCRIPTION	CHG. NO.	APP'D	DATE
AG				

MODEL 3051G

FOR OUTPUT CODE A

CLASS I, DIV. 1, GROUPS A AND B

$V_{MAX} = 30V$	V_t or V_{oc} IS LESS THAN OR EQUAL TO 30V
$I_{MAX} = 165mA$	I_t or I_{sc} IS LESS THAN OR EQUAL TO 165mA
$P_{MAX} = 1 WATT$	$(V_{oc} \times I_{sc}/4)$ or $(V_t \times I_t/4)$ IS LESS THAN OR EQUAL TO 1 WATT
$C_i = 0.01 \mu F$	C_A IS GREATER THAN $0.01 \mu F + C_{CABLE}$
$L_i = 10 \mu H$	L_A IS GREATER THAN $10 \mu H + L_{CABLE}$

FOR T1 OPTION:

$I_{MAX} = 160mA$	I_t or I_{sc} IS LESS THAN OR EQUAL TO 145mA
$L_i = 1.06 mH$	L_A IS GREATER THAN $1.06 mH + L_{CABLE}$

CLASS I, DIV. 1, GROUPS C AND D

$V_{MAX} = 30V$	V_t or V_{oc} IS LESS THAN OR EQUAL TO 30V
$I_{MAX} = 225mA$	I_t or I_{sc} IS LESS THAN OR EQUAL TO 225mA
$P_{MAX} = 1 WATT$	$(V_{oc} \times I_{sc}/4)$ or $(V_t \times I_t/4)$ IS LESS THAN OR EQUAL TO 1 WATT
$C_i = 0.01 \mu F$	C_A IS GREATER THAN $0.01 \mu F + C_{CABLE}$
$L_i = 10 \mu H$	L_A IS GREATER THAN $10 \mu H + L_{CABLE}$

FOR T1 OPTION:

$L_i = 1.06 mH$	L_A IS GREATER THAN $1.06 mH + L_{CABLE}$
-----------------	---

Rosemount Inc. 8200 Market Boulevard Chanhassen, MN 55317 USA	CAD MAINTAINED (MicroStation)
DR. Myles Lee Miller	SIZE A FSCM NO DWG NO. 03031-1019
ISSUED	SCALE N/A WT. _____ SHEET 5 OF 13

Form Rev AC

REVISIONS				
REV	DESCRIPTION	CHG. NO.	APP'D	DATE
AG				

FOR OUTPUT CODE M

CLASS I, DIV. 1, GROUPS A AND B

$V_{MAX} = 30V$	V_T OR V_{OC} IS LESS THAN OR EQUAL TO 30V
$I_{MAX} = 165mA$	I_T OR I_{SC} IS LESS THAN OR EQUAL TO 165mA
$P_{MAX} = 1$ WATT	$(\frac{V_T \times I_T}{4})$ OR $(\frac{V_{OC} \times I_{SC}}{4})$ IS LESS THAN OR EQUAL TO 1 WATT
$C_I = .042\mu f$	C_A IS GREATER THAN $.042\mu f$
$L_I = 10\mu H$	L_A IS GREATER THAN $10\mu H$

* FOR T1 OPTION:

$L_I = 0.75mH$	L_A IS GREATER THAN $0.75mH$
----------------	--------------------------------

CLASS I, DIV. 1, GROUPS C AND D

$V_{MAX} = 30V$	V_T OR V_{OC} IS LESS THAN OR EQUAL TO 30V
$I_{MAX} = 225mA$	I_T OR I_{SC} IS LESS THAN OR EQUAL TO 225mA
$P_{MAX} = 1$ WATT	$(\frac{V_T \times I_T}{4})$ OR $(\frac{V_{OC} \times I_{SC}}{4})$ IS LESS THAN OR EQUAL TO 1 WATT
$C_I = .042\mu f$	C_A IS GREATER THAN $.042\mu f$
$L_I = 10\mu H$	L_A IS GREATER THAN $10\mu H$

* FOR T1 OPTION:

$L_I = 0.75mH$	L_A IS GREATER THAN $0.75mH$
----------------	--------------------------------

HAZARDOUS AREA | NON-HAZARDOUS AREA

ASSOCIATED APPARATUS

OUTPUT CODE M
AVAILABLE FOR THE MODELS LISTED

305IC	305IH
305IL	305ICA
305IP	305IT

Rosemount Inc. 8200 Market Boulevard Chanhassen, MN 55317 USA	CAD MAINTAINED (MicroStation)
DR. MIKE DOBE	SIZE A FSCM NO DWG NO. 03031-1019
ISSUED	SCALE N/A WT. SHEET 6 OF 13

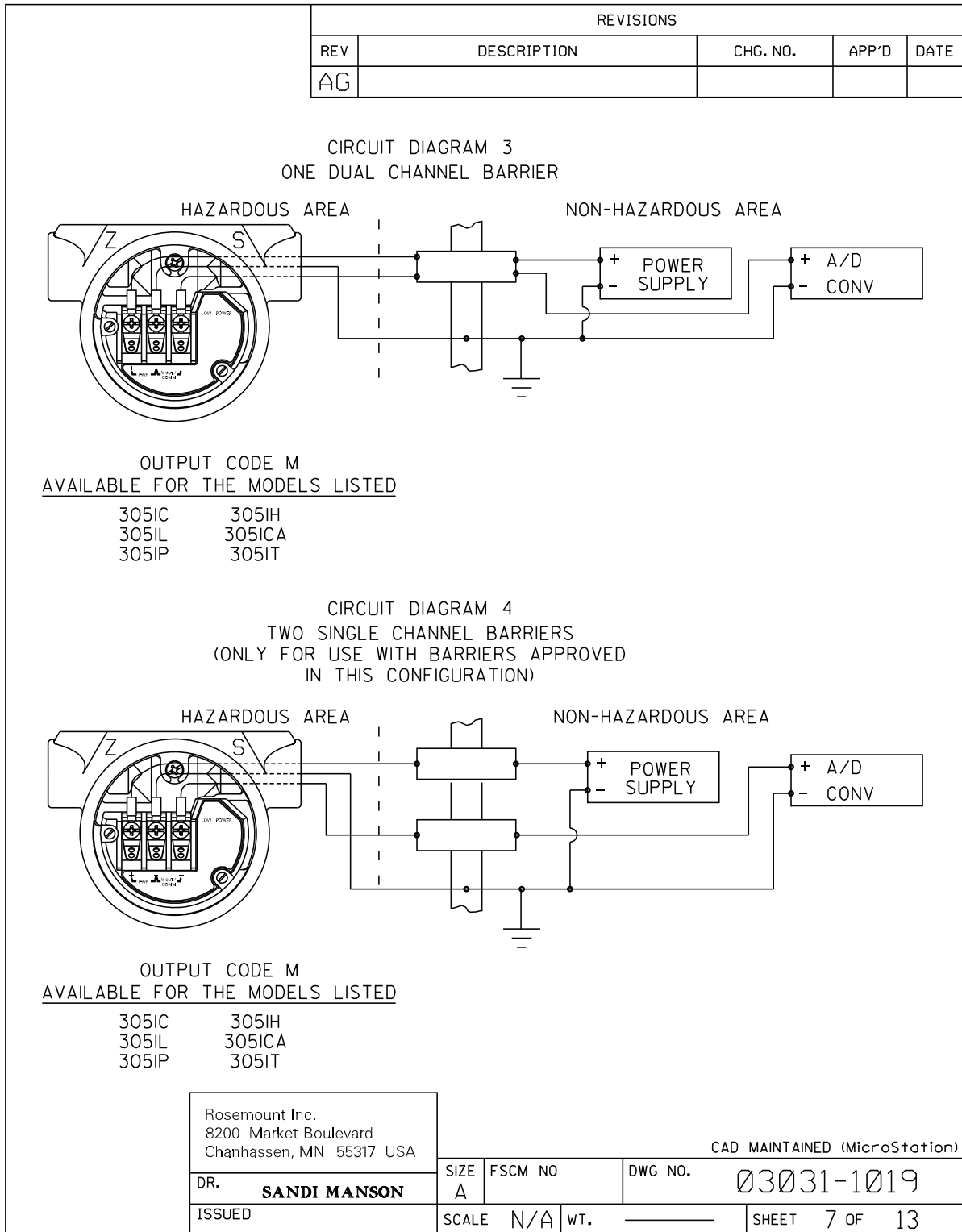

REVISIONS				
REV	DESCRIPTION	CHG. NO.	APP'D	DATE
AG				

3051 WITH FOUNDATION FIELDBUS OR PROFIBUS.
(OUTPUT CODE F OR W)

BARRIER PARAMETERS (APPLICABLE TO OUTPUT CODE F OR W)
 $P_{max} = 1.3 \text{ WATT}$

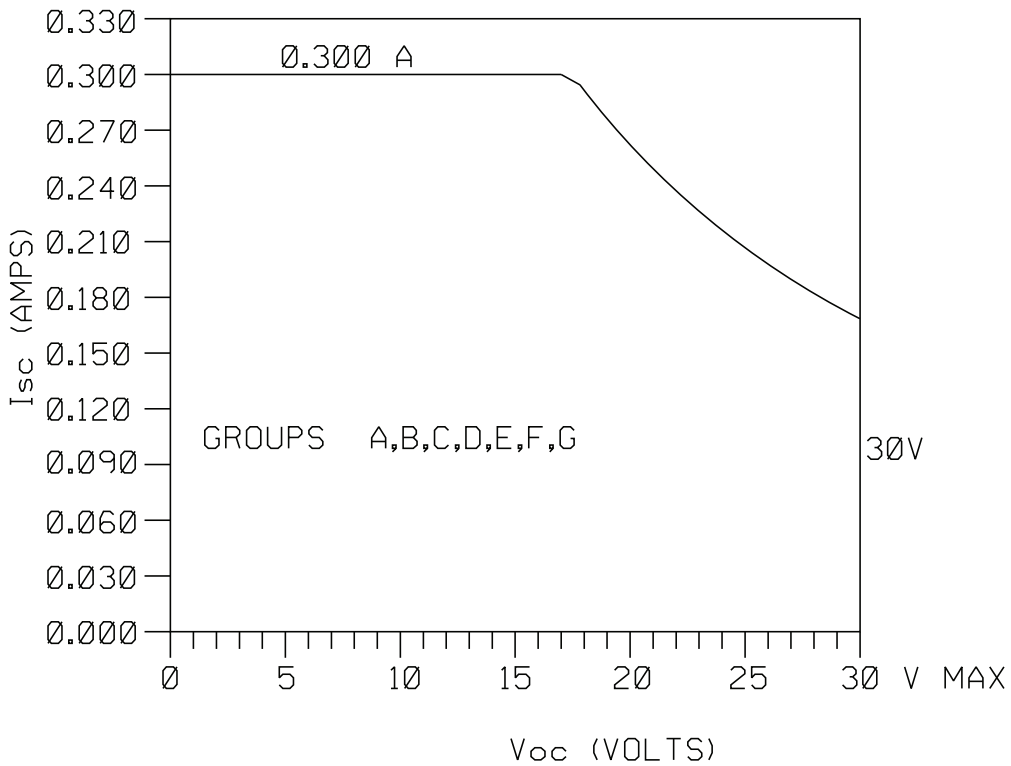

Rosemount Inc. 8200 Market Boulevard Chanhassen, MN 55317 USA		CAD MAINTAINED (MicroStation)		
DR. Myles Lee Miller	SIZE A	FSCM NO	DWG NO. 03031-1019	
ISSUED	SCALE N/A	WT.	SHEET 8 OF 13	

From Rev AC

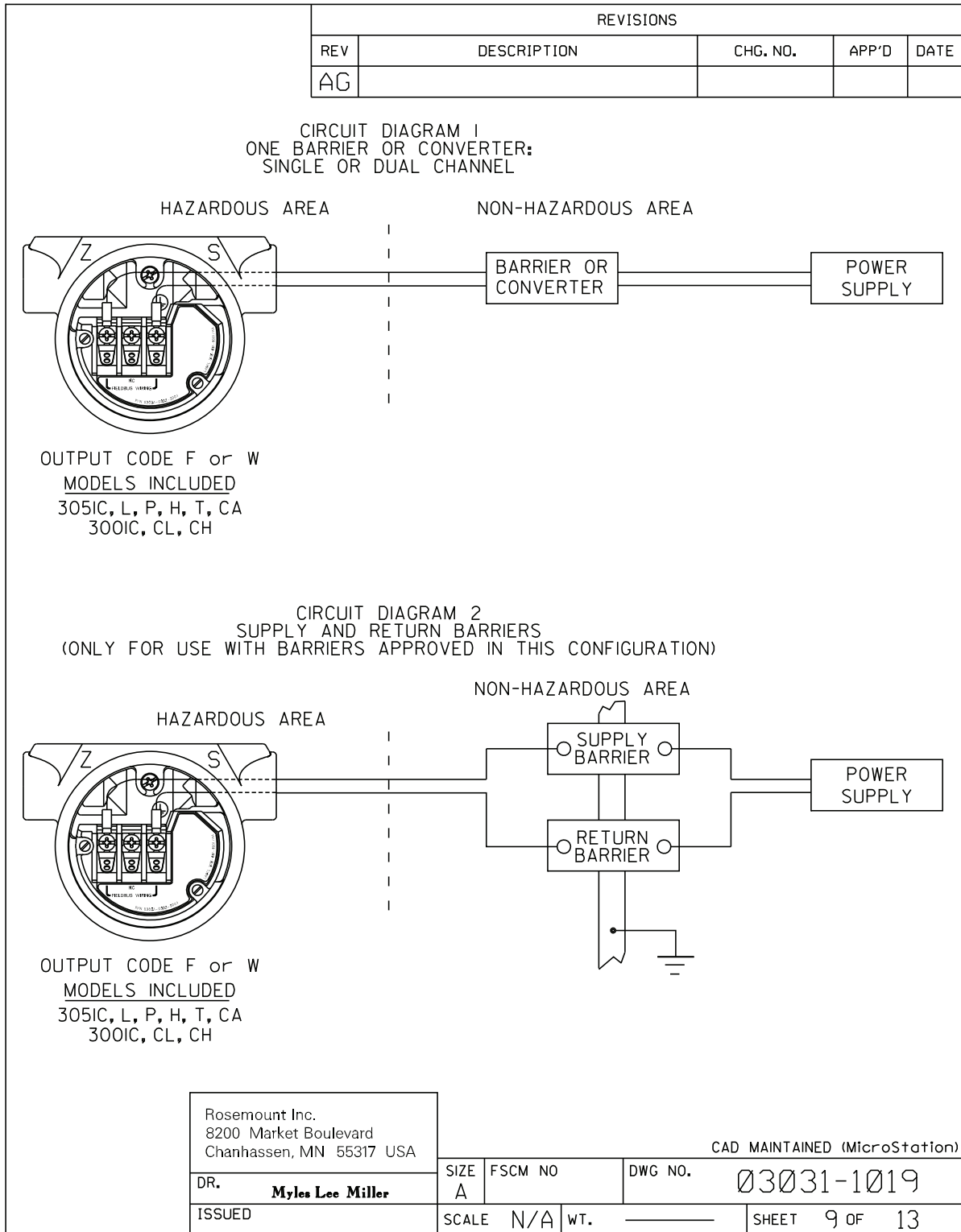

Form Rev AC

REVISIONS				
REV	DESCRIPTION	CHG. NO.	APP'D	DATE
AG				

ENTITY CONCEPT APPROVALS

THE ENTITY CONCEPT ALLOWS INTERCONNECTION OF INTRINSICALLY SAFE APPARATUS TO ASSOCIATED APPARATUS NOT SPECIFICALLY EXAMINED IN COMBINATION AS A SYSTEM. THE APPROVED VALUES OF MAX. OPEN CIRCUIT VOLTAGE (V_{oc} OR V_t) AND MAX. SHORT CIRCUIT CURRENT (I_{sc} OR I_t) AND MAX. POWER ($V_{oc} \times I_{sc}/4$) OR ($V_t \times I_t/4$), FOR THE ASSOCIATED APPARATUS MUST BE LESS THAN OR EQUAL TO THE MAXIMUM SAFE INPUT VOLTAGE (V_{max}), MAXIMUM SAFE INPUT CURRENT (I_{max}), AND MAXIMUM SAFE INPUT POWER (P_{max}) OF THE INTRINSICALLY SAFE APPARATUS. IN ADDITION, THE APPROVED MAX. ALLOWABLE CONNECTED CAPACITANCE (C_a) OF THE ASSOCIATED APPARATUS MUST BE GREATER THAN THE SUM OF THE INTERCONNECTING CABLE CAPACITANCE AND THE UNPROTECTED INTERNAL CAPACITANCE (C_i) OF THE INTRINSICALLY SAFE APPARATUS, AND THE APPROVED MAX. ALLOWABLE CONNECTED INDUCTANCE (L_a) OF THE ASSOCIATED APPARATUS MUST BE GREATER THAN THE SUM OF THE INTERCONNECTING CABLE INDUCTANCE AND THE UNPROTECTED INTERNAL INDUCTANCE (L_i) OF THE INTRINSICALLY SAFE APPARATUS.

NOTE: ENTITY PARAMETERS LISTED APPLY ONLY TO ASSOCIATED APPARATUS WITH LINEAR OUTPUT.

FOR OUTPUT CODE F or W

CLASS I, DIV. 1, GROUPS A, B, C AND D

$V_{MAX} = 30V$	V_t OR V_{oc} IS LESS THAN OR EQUAL TO 30V
$I_{MAX} = 300mA$	I_t OR I_{sc} IS LESS THAN OR EQUAL TO 300mA
$P_{MAX} = 1.3 \text{ WATT}$	$(\frac{V_t \times I_t}{4})$ OR $(\frac{V_{oc} \times I_{sc}}{4})$ IS LESS THAN OR EQUAL TO 1.3 WATT
$C_i = 0 \mu f$	C_a IS GREATER THAN $0 \mu f$
$L_i = 0 \mu H$	L_a IS GREATER THAN $0 \mu H$

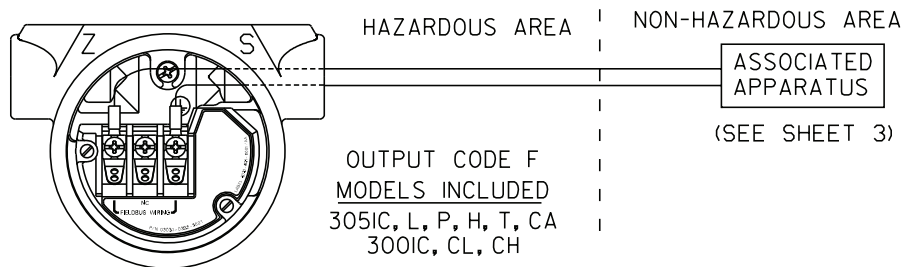

Rosemount Inc.
8200 Market Boulevard
Chanhassen, MN 55317 USA

CAD MAINTAINED (MicroStation)

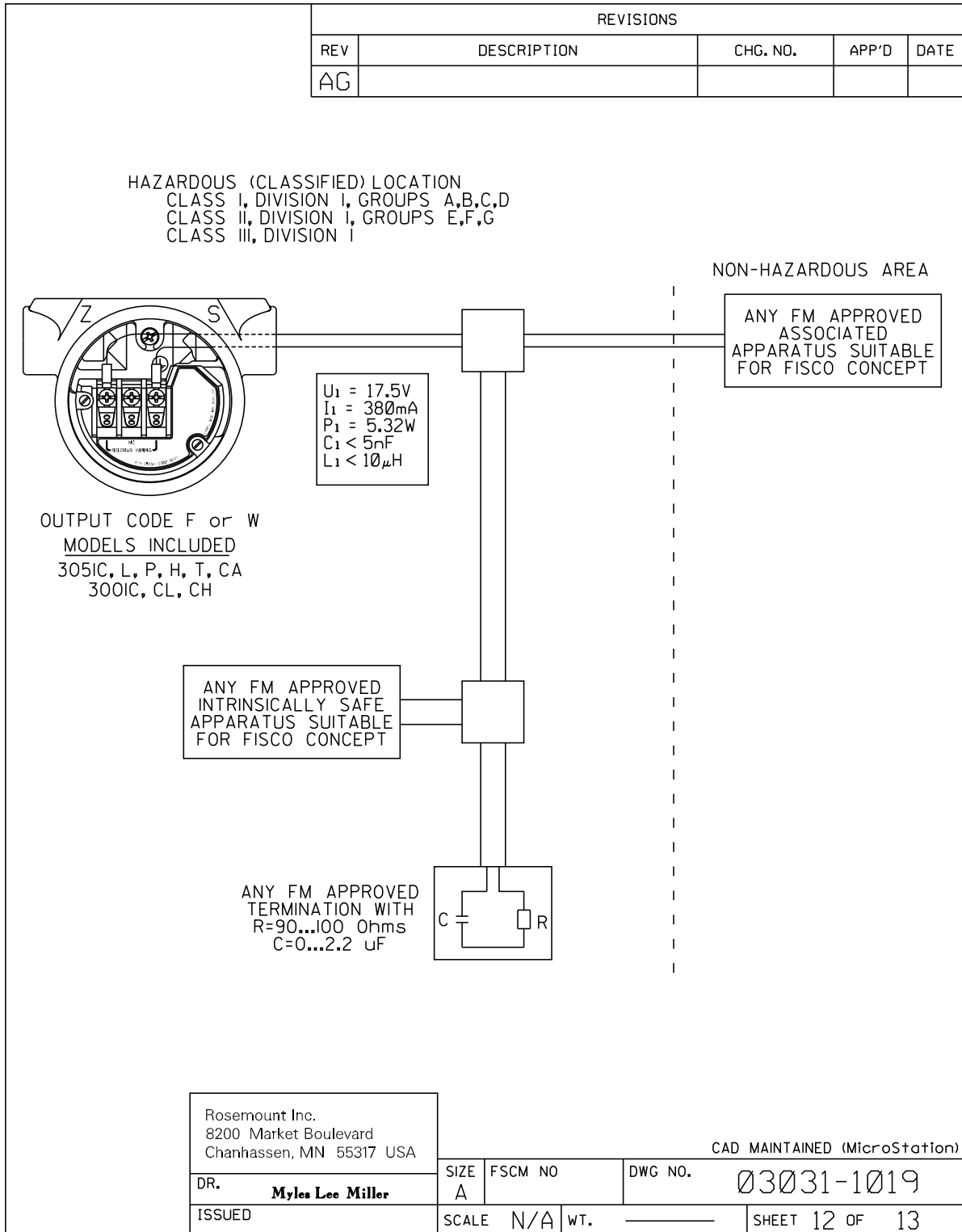

DR. Myles Lee Miller	SIZE A	FSCM NO.	DWG NO. 03031-1019
ISSUED	SCALE N/A	WT.	SHEET 10 OF 13

From Rev. AC

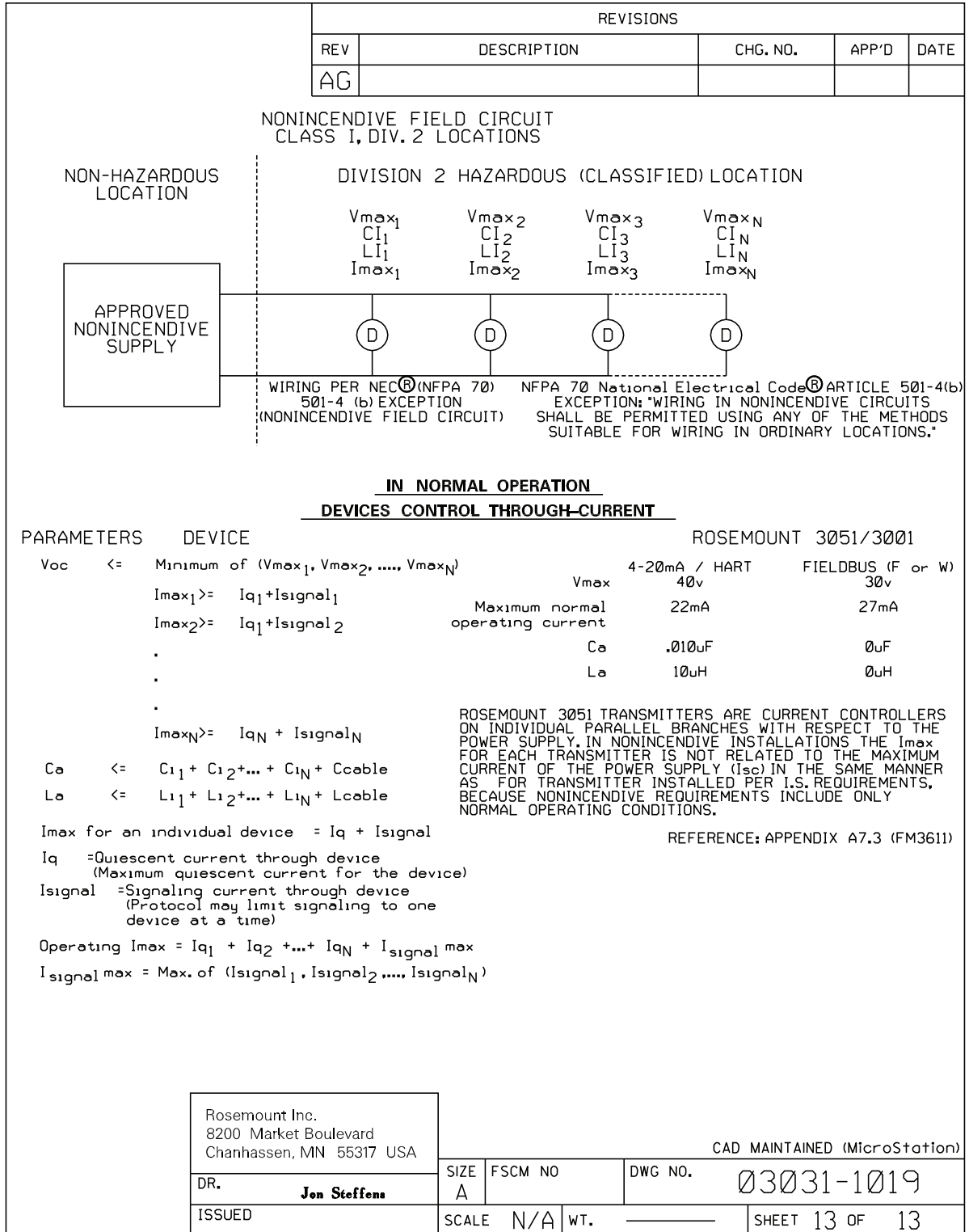



B.13.2 Canadian standards association (CSA) 03031-1024

CONFIDENTIAL AND PROPRIETARY INFORMATION IS CONTAINED HEREIN AND MUST BE HANDLED ACCORDINGLY	REVISIONS			
	REV	DESCRIPTION	CHG. NO.	APP'D DATE
	AA	ADD FIELDBUS	RTC1004232	M.L.M. 5/28/98
	AB	ADD PROFIBUS, ENTITY PARAMETERS	RTC1008326	P.C.S. 2/4/00
	AC	REM It, Vt FROM ENTITY PARAMETERS	RTC1009279	W.C.R. 7/11/00
	AD	ADD FISCO FIELDBUS	RTC1012624	J.P.W. 4/4/02
<p>APPROVALS FOR</p> <p>3051C 3001C 3051L 3001CL 3051P 3001CH 3051H 3001S 3051CA 3001SL 3051T 3001SH</p> <p>OUTPUT CODE A (4-20 mA HART) I.S. SEE SHEETS 2-3 OUTPUT CODE M (LOW POWER) I.S. SEE SHEETS 3-4 OUTPUT CODE F/W (FIELDBUS) I.S. SEE SHEETS 5-7 OUTPUT CODES A,F,W I.S. ENTITY PARAMETERS SHEET 8-9</p> <p>TO ASSURE AN INTRINSICALLY SAFE SYSTEM, THE TRANSMITTER AND BARRIER MUST BE WIRED IN ACCORDANCE WITH THE BARRIER MANUFACTURER'S FIELD WIRING INSTRUCTIONS AND THE APPLICABLE CIRCUIT DIAGRAM.</p> <p>WARNING - EXPLOSION HAZARD - SUBSTITUTION OF COMPONENTS MAY IMPAIR SUITABILITY FOR CLASS I, DIVISION 2.</p> <p>AVERTISSEMENT - RISQUE D'EXPLOSION - LA SUBSTITUTION DE COMPOSANTS PEUT RENDRE CE MATERIEL INACCEPTABLE POUR LES EMBLEMES DE CLASSE I, DIVISION 2.</p>				
CAD MAINTAINED (MicroStation)				
UNLESS OTHERWISE SPECIFIED DIMENSIONS IN INCHES (mm). REMOVE ALL BURRS AND SHARP EDGES. MACHINE SURFACE FINISH I25 -TOLERANCE- .X ± .1 [2,5] .XX ± .02 [0,5] .XXX ± .010 [0,25] FRACTIONS ANGLES ± 1/32 ± 2° DO NOT SCALE PRINT	CONTRACT NO.	  8200 Market Boulevard • Chanhassen, MN 56817 USA		
	DR. Mike Dobe 08/27/90			
	CHK'D	INDEX OF I.S. CSA FOR		
	APP'D. GLEN MONZO 8/31/90	3051C/L/P/H/T & 3001C/S		
	APP'D. GOVT.	SIZE A FSCM NO DWG NO. 03031-1024 SCALE N/A WT. _____ SHEET 1 OF 9		

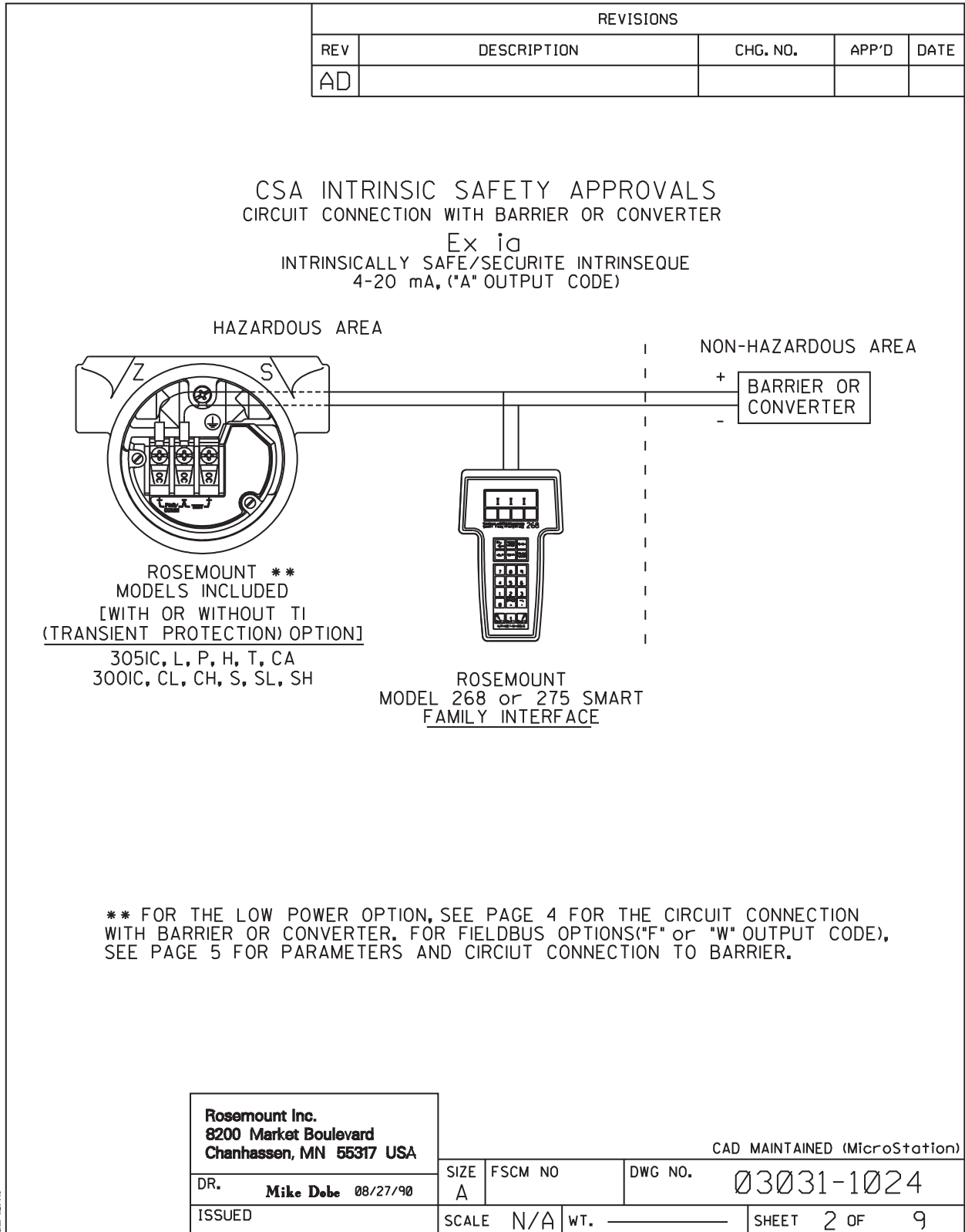

		REVISIONS			
REV	DESCRIPTION	CHG. NO.	APP'D	DATE	
AD					
4-2Ø mA, ("A" OUTPUT CODE)					
DEVICE		PARAMETERS		APPROVED FOR CLASS I, DIV.I	
CSA APPROVED SAFETY BARRIER		30 V OR LESS * 330 OHMS OR MORE * 28 V OR LESS * 300 OHMS OR MORE 25 V OR LESS 200 OHMS OR MORE * 22 V OR LESS * 180 OHMS OR MORE		GROUPS A, B, C, D	
FOXBORO CONVERTER 2AI-12V-CGB, 2AI-13V-CGB, 2AS-13I-CGB, 3A2-12D-CGB, 3A2-13D-CGB, 3AD-13I-CGB, 3A4-12D-CGB, 2AS-12I-CGB, 3F4-12DA				GROUPS B, C, D	
CSA APPROVED SAFETY BARRIER		30 V OR LESS 150 OHMS OR MORE		GROUPS C, D	
LOW POWER, ("M" OUTPUT CODE)					
DEVICE		PARAMETERS		APPROVED FOR CLASS I, DIV.I	
CSA APPROVED SAFETY BARRIER		Supply $\leq 28V, \geq 300 \Omega$ Return $\leq 10V, \geq 47 \Omega$		GROUPS A, B, C, D	
CSA APPROVED SAFETY BARRIER		Supply $\leq 30V, \geq 150 \Omega$ Return $\leq 10V, \geq 47 \Omega$		GROUPS C, D	
* MAY BE USED WITH ROSEMOUNT MODEL 268 or 275 SMART FAMILY INTERFACE.					
Rosemount Inc. 8200 Market Boulevard Chanhassen, MN 55317 USA		CAD MAINTAINED (MicroStation)			
		DR.	SIZE	FSCM NO	DWG NO.
		Mike Dobe	A		03031-1024
ISSUED	SCALE	N/A	WT.		SHEET 3 OF 9

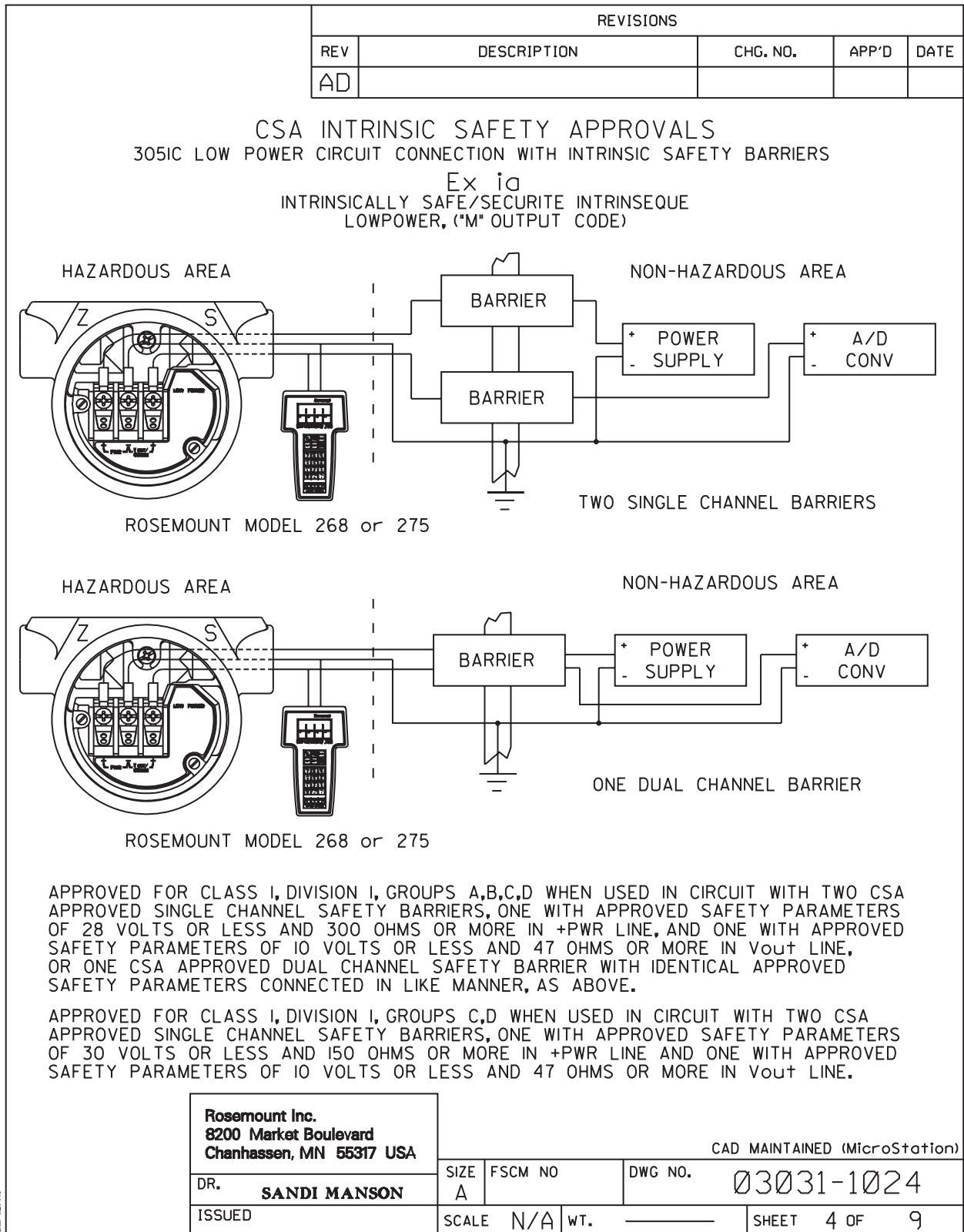

REVISIONS				
REV	DESCRIPTION	CHG. NO.	APP'D	DATE
AD				

FIELDBUS, ("F" or "W" OUTPUT CODE)

DEVICE	PARAMETERS	APPROVED FOR CLASS I, DIV. I
CSA APPROVED SAFETY BARRIER	30 V OR LESS 300 OHMS OR MORE	GROUPS A, B, C, D
	28 V OR LESS 235 OHMS OR MORE	
	25 V OR LESS 160 OHMS OR MORE	
	22 V OR LESS 100 OHMS OR MORE	

CSA INTRINSIC SAFETY APPROVALS
CIRCUIT CONNECTION WITH BARRIER OR CONVERTER

Ex ia
INTRINSICALLY SAFE/SECURITE INTRINSEQUE
FIELDBUS, ("F" or "W" OUTPUT CODE)

HAZARDOUS AREA

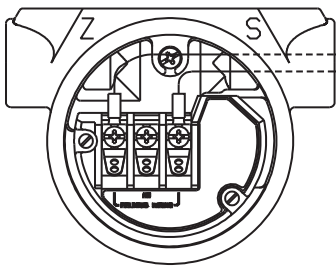

NON-HAZARDOUS AREA



ROSEMOUNT **
MODELS INCLUDED
[WITH OR WITHOUT TI
(TRANSIENT PROTECTION) OPTION]

305IC, L, P, H, T, CA
300IC, CL, CH, S, SL, SH

WARNING - EXPLOSION HAZARD - SUBSTITUTION OF COMPONENTS
MAY IMPAIR SUITABILITY FOR CLASS I, DIVISION 2.

AVERTISSEMENT - RISQUE D'EXPLOSION - LA SUBSTITUTION DE COMPOSANTS
PEUT RENDRE CE MATERIEL INACCEPTABLE POUR LES EMBLEMES
DE CLASSE I, DIVISION 2.

Rosemount Inc. 8200 Market Boulevard Chanhassen, MN 55317 USA		CAD MAINTAINED (MicroStation)		
DR. Myles Lee Miller	SIZE A	FSCM NO	DWG NO. 03031-1024	
ISSUED	SCALE N/A	WT. _____	SHEET 5 OF 9	

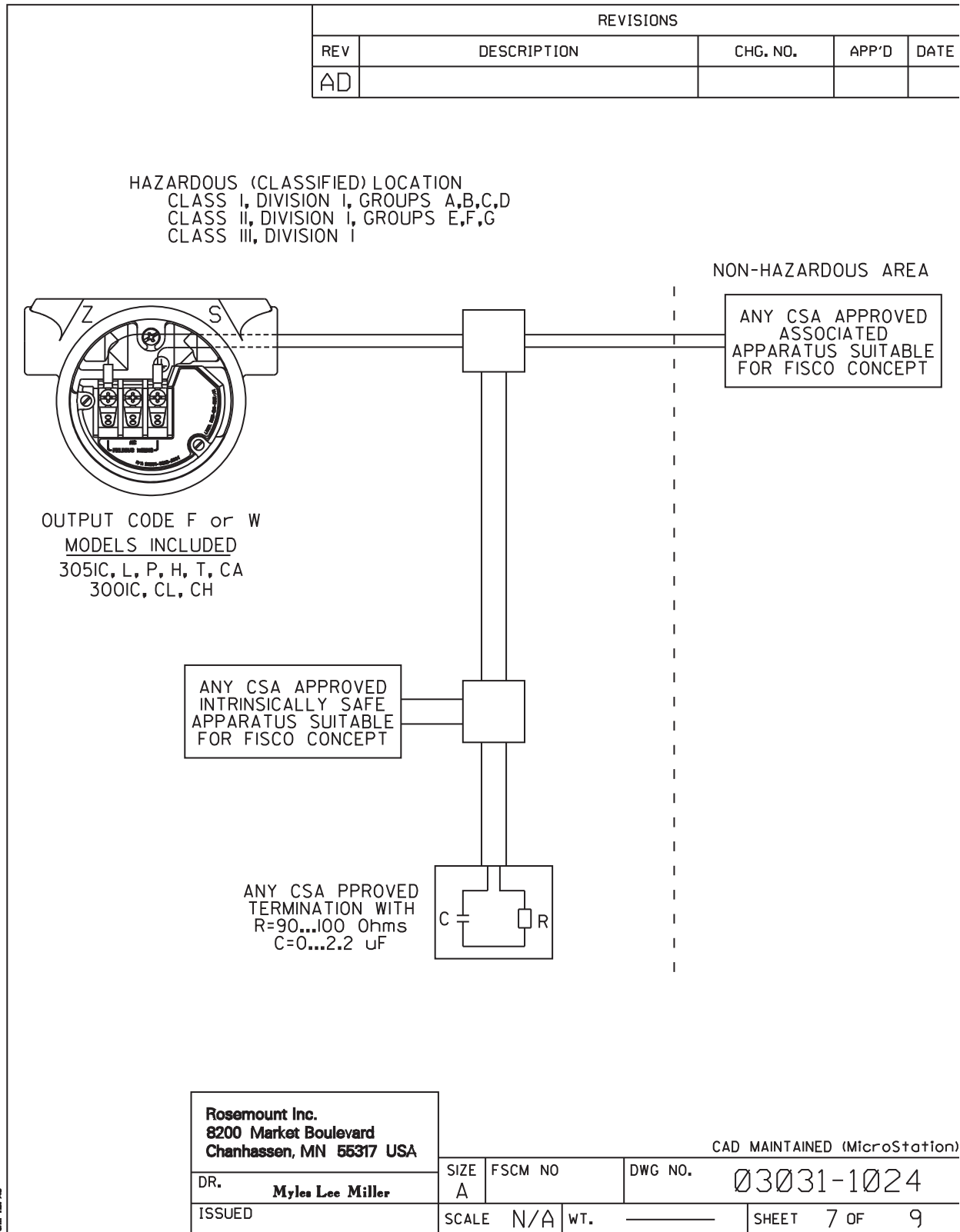

REVISIONS				
REV	DESCRIPTION	CHG. NO.	APP'D	DATE
AD				

3051 I.S. ENTITY PARAMETERS.
(OUTPUT CODE A,F, or W)

BARRIER PARAMETERS (APPLICABLE TO OUTPUT CODE A,F, or W)

$P_{max} = 1.3$ WATT OUTPUT F or W
 $P_{max} = 1.0$ WATT OUTPUT A

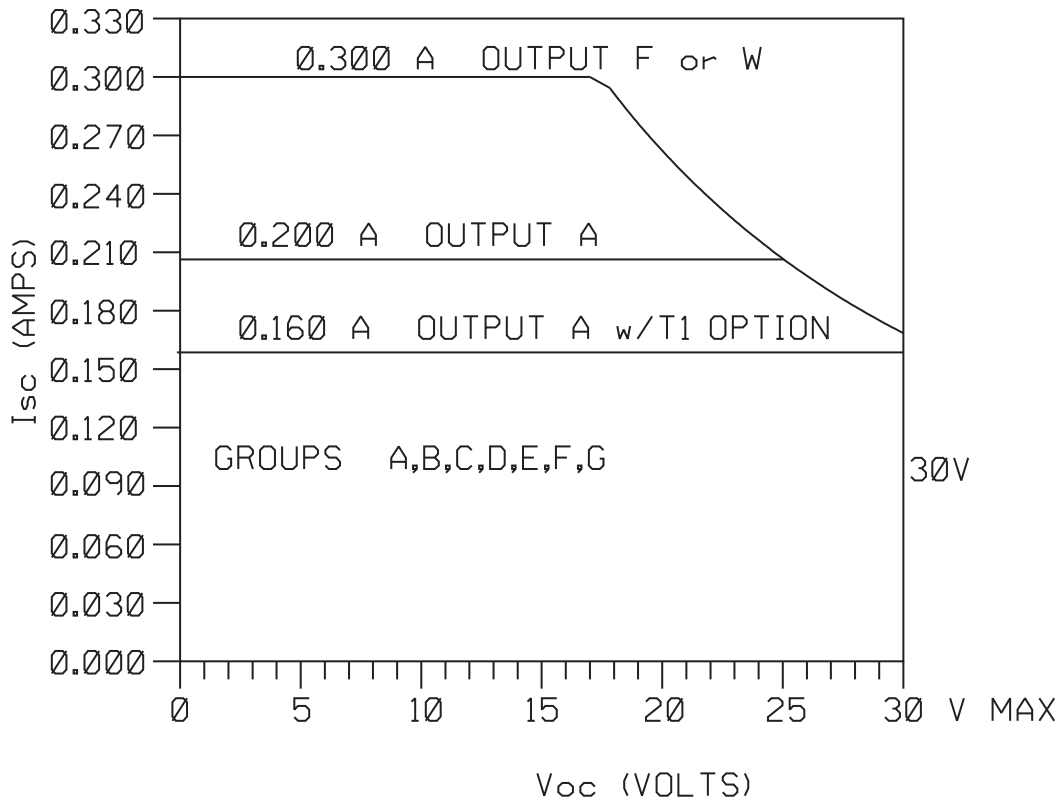

Rosemount Inc. 8200 Market Boulevard Chanhassen, MN 55317 USA		CAD MAINTAINED (MicroStation)		
DR. JON STEFFENS	SIZE A	FSCM NO	DWG NO.	03031-1024
ISSUED	SCALE N/A	WT.	SHEET 8 OF	9

REVISIONS				
REV	DESCRIPTION	CHG. NO.	APP'D	DATE
AD				

ENTITY CONCEPT APPROVALS

THE ENTITY CONCEPT ALLOWS INTERCONNECTION OF INTRINSICALLY SAFE APPARATUS TO ASSOCIATED APPARATUS NOT SPECIFICALLY EXAMINED IN COMBINATION AS A SYSTEM. THE APPROVED VALUES OF MAX. OPEN CIRCUIT VOLTAGE (V_{oc}) AND MAX. SHORT CIRCUIT CURRENT (I_{sc}) AND MAX. POWER ($V_{oc} \times I_{sc}/4$), FOR THE ASSOCIATED APPARATUS MUST BE LESS THAN OR EQUAL TO THE MAXIMUM SAFE INPUT VOLTAGE (V_{max}), MAXIMUM SAFE INPUT CURRENT (I_{max}), AND MAXIMUM SAFE INPUT POWER (P_{max}) OF THE INTRINSICALLY SAFE APPARATUS. IN ADDITION, THE APPROVED MAX. ALLOWABLE CONNECTED CAPACITANCE (C_a) OF THE ASSOCIATED APPARATUS MUST BE GREATER THAN THE SUM OF THE INTERCONNECTING CABLE CAPACITANCE AND THE UNPROTECTED INTERNAL CAPACITANCE (C_i) OF THE INTRINSICALLY SAFE APPARATUS, AND THE APPROVED MAX. ALLOWABLE CONNECTED INDUCTANCE (L_a) OF THE ASSOCIATED APPARATUS MUST BE GREATER THAN THE SUM OF THE INTERCONNECTING CABLE INDUCTANCE AND THE UNPROTECTED INTERNAL INDUCTANCE (L_i) OF THE INTRINSICALLY SAFE APPARATUS.

FOR OUTPUT CODE A

CLASS I, DIV. 1, GROUPS A, B, C AND D

$V_{MAX} = 30V$	V_{OC} IS LESS THAN OR EQUAL TO 30V
$I_{MAX} = 200mA$	I_{SC} IS LESS THAN OR EQUAL TO 200mA
$P_{MAX} = 1 \text{ WATT}$	$(\frac{V_{oc} \times I_{sc}}{4})$ IS LESS THAN OR EQUAL TO 1 WATT
$C_i = .01\mu f$	C_A IS GREATER THAN $.01\mu f + C$ CABLE
$L_i = 10\mu H$	L_A IS GREATER THAN $10\mu H + L$ CABLE

* FOR T1 OPTION:

$I_{max} = 160mA$	I_{SC} IS LESS THAN OR EQUAL TO 160mA
$L_i = 1.05mH$	L_A IS GREATER THAN $1.05mH + L$ CABLE

FOR OUTPUT CODE F or W

CLASS I, DIV. 1, GROUPS A, B, C AND D

$V_{MAX} = 30V$	V_{OC} IS LESS THAN OR EQUAL TO 30V
$I_{MAX} = 300mA$	I_{SC} IS LESS THAN OR EQUAL TO 300mA
$P_{MAX} = 1.3 \text{ WATT}$	$(\frac{V_{oc} \times I_{sc}}{4})$ IS LESS THAN OR EQUAL TO 1.3 WATT
$C_i = 0\mu f$	C_A IS GREATER THAN $0\mu f + C$ CABLE
$L_i = 0\mu H$	L_A IS GREATER THAN $0\mu H + L$ CABLE

NOTE: ENTITY PARAMETERS LISTED APPLY ONLY TO ASSOCIATED APPARATUS WITH LINEAR OUTPUT.

Rosemount Inc. 8200 Market Boulevard Chanhassen, MN 55317 USA		CAD MAINTAINED (MicroStation)		
DR. JON STEFFENS	SIZE A	FSCM NO.	DWG NO.	03031-1024
ISSUED	SCALE N/A	WT.	SHEET 9 OF	9

Global Headquarters

Emerson Automation Solutions

6021 Innovation Blvd.
Shakopee, MN 55379, USA
+1 800 999 9307 or +1 952 906 8888
+1 952 949 7001
RFQ.RMD-RCC@Emerson.com

North America Regional Office

Emerson Automation Solutions

8200 Market Blvd.
Chanhassen, MN 55317, USA
+1 800 999 9307 or +1 952 906 8888
+1 952 949 7001
RMT-NA.RCCRFQ@Emerson.com

Latin America Regional Office

Emerson Automation Solutions

1300 Concord Terrace, Suite 400
Sunrise, FL 33323, USA
+1 954 846 5030
+1 954 846 5121
RFQ.RMD-RCC@Emerson.com

Europe Regional Office

Emerson Automation Solutions Europe GmbH

Neuhofstrasse 19a P.O. Box 1046
CH 6340 Baar
Switzerland
+41 (0) 41 768 6111
+41 (0) 41 768 6300
RFQ.RMD-RCC@Emerson.com

Asia Pacific Regional Office

Emerson Automation Solutions Asia Pacific Pte Ltd

1 Pandan Crescent
Singapore 128461
+65 6777 8211
+65 6777 0947
Enquiries@AP.Emerson.com

Middle East and Africa Regional Office

Emerson Automation Solutions

Emerson FZE P.O. Box 17033
Jebel Ali Free Zone - South 2
Dubai, United Arab Emirates
+971 4 8118100
+971 4 8865465
RFQ.RMTMEA@Emerson.com



Linkedin.com/company/Emerson-Automation-Solutions



Twitter.com/Rosemount_News



Facebook.com/Rosemount



Youtube.com/user/RosemountMeasurement



Google.com/+RosemountMeasurement

Standard Terms and Conditions of Sale can be found on the [Terms and Conditions of Sale page](#).

The Emerson logo is a trademark and service mark of Emerson Electric Co. Coplanar, Instrument Toolkit, Plantweb, Rosemount, and Rosemount logotype are trademarks of Emerson.

Fluorinert is a trademark of 3M.

Syltherm 800 and D.C. Silicone 704 are registered trademarks of Dow Corning Corporation.

Neobee is a registered trademark of Stepan Specialty Products, LLC.

HART is a registered trademark of the FieldComm Group.

FOUNDATION Fieldbus is a trademark of the FieldComm Group.

eurofast and minifast are registered trademark of TURCK.

All other marks are the property of their respective owners.

© 2017 Emerson. All rights reserved.